

SeisImager/2D™ Manual

Version 3.3

Pickwin v. 4.0.1.5
Plotrefa v. 2.9.1.6

October 2009

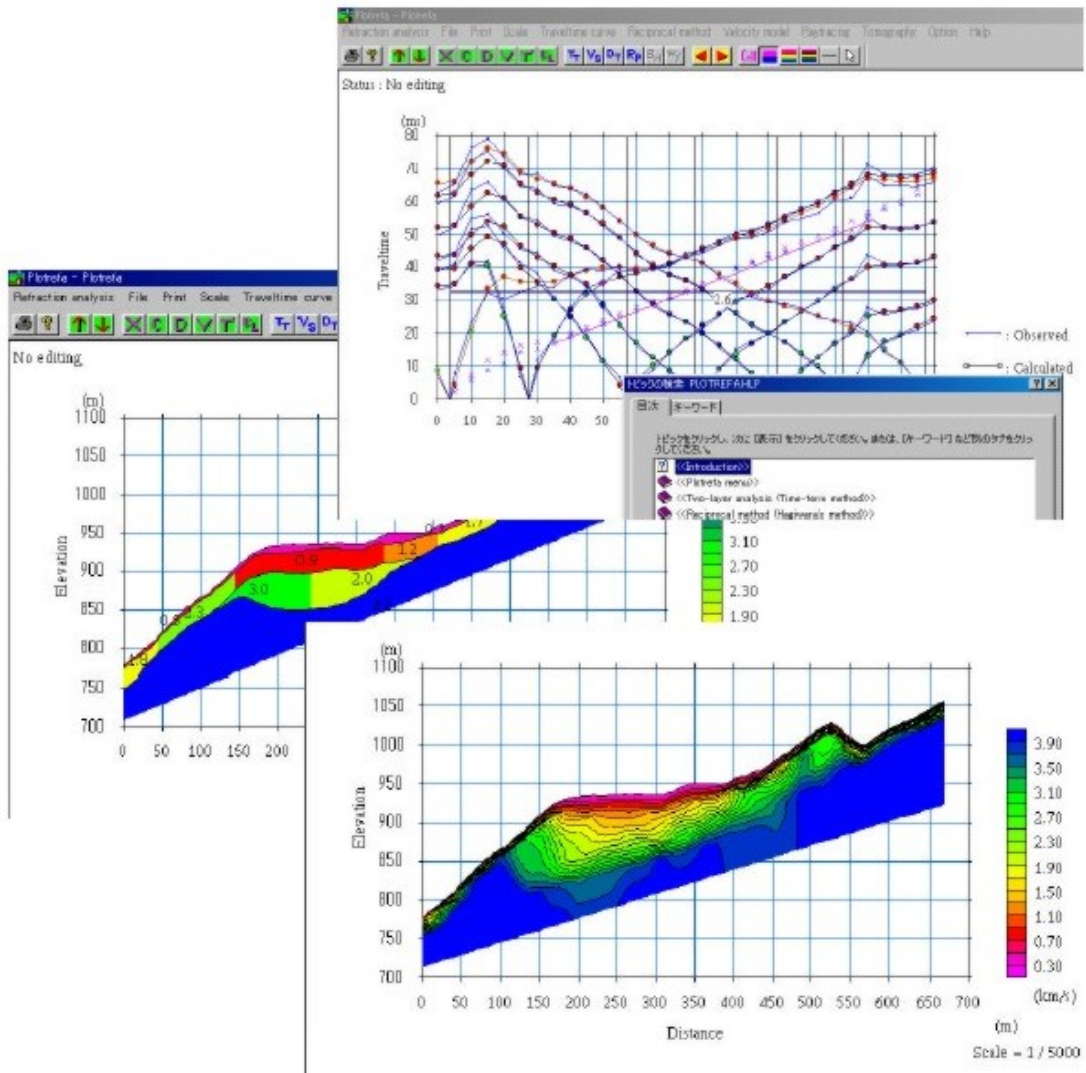

Table of Contents

1	INTRODUCTION.....	7
2	INSTALLING THE SOFTWARE	9
3	THE PICKWIN™ MODULE	21
3.1	FILE MENU.....	23
3.1.1	Open SEG2 File.....	23
3.1.2	Save SEG2 File.....	24
3.1.3	Open SEG2 File (SmartSeis)	24
3.1.4	Open McSeis-3 File.....	24
3.1.5	Open OYO 160MX (SEG1) file.....	24
3.1.6	Open First Break Pick File.....	25
3.1.7	Save First Break Pick File.....	25
3.1.8	Print Window Display.....	27
3.1.9	Print Preview	27
3.1.10	Page Setup	28
3.1.11	Group (File list).....	29
3.1.11.1	Make File List.....	30
3.1.11.2	Open File List	33
3.1.11.3	Save File List (text).....	35
3.1.11.4	Save File List (XML).....	35
3.1.11.5	Show File List.....	36
3.1.12	Last Four Files Opened	36
3.1.13	Exit.....	37
3.2	EDIT/DISPLAY MENU.....	37
3.2.1	Undo.....	37
3.2.2	Redo	38
3.2.3	Select Trace [.....	38
3.2.4	Select All Traces	39
3.2.5	Selected Traces	41
3.2.5.1	Reverse Polarity	42
3.2.5.2	Kill	42
3.2.5.3	Delete.....	43
3.2.6	Time Shift Traces	44
3.2.7	Correct Shot Time.....	45
3.2.8	Automatic Shift.....	47
3.2.9	Correct S-wave.....	51
3.2.10	Filter	54
3.2.11	Truncate Traces (Shorten Record Length)	56
3.2.12	Resample Data.....	57
3.2.13	Edit Source/Receiver Locations, Etc.....	58
3.3	VIEW MENU.....	59

3.3.1	<i>Normalize Traces [</i>	60
3.3.2	<i>Clip Traces [</i>	61
3.3.3	<i>Trace Shading [</i>	62
3.3.4	<i>Number of Traces Shown</i>	64
3.3.5	<i>Show Traveltime Curves [</i>	64
3.3.6	<i>Axis Configuration</i>	65
3.3.7	<i>Pre-trigger Shift [</i>	66
3.4	PICK FIRST ARRIVALS MENU	67
3.4.1	<i>Pick First Breaks</i>	67
	Audio/video clip of First Break Picking Procedure	68
3.4.2	<i>Linear Velocity Line</i>	68
3.4.3	<i>Delete All Velocity Lines</i>	69
3.5	SURFACE-WAVE ANALYSIS MENU	69
3.6	OPTION MENU	69
3.6.1	<i>Dimension Size</i>	70
3.7	HELP MENU	70
3.7.1	<i>Version Info. (Pickwin) (A)</i>	70
3.8	ADDITIONAL TOOL BUTTONS AND HOT KEYS	71
3.8.1	<i>Increase Amplitude Tool Button and Hot Key</i> ↑	71
3.8.2	<i>Decrease Amplitude Tool Button and Hot Key</i> ↓	71
3.8.3	<i>Increase Horizontal Axis Tool Button and Hot Key</i> →	72
3.8.4	<i>Decrease Horizontal Axis Tool Button and Hot Key</i> ←	73
3.8.5	<i>Increase Vertical Axis Tool Button and Hot Key</i> SHIFT ↑	74
3.8.6	<i>Decrease Vertical Axis Tool Button and Hot Key</i> SHIFT ↓	75
3.8.7	<i>Draw Traveltime Curve Tool Button</i>	76
3.8.8	<i>“X” Tool Button</i>	76
3.8.9	<i>Page Up Tool Button</i>	77
3.8.10	<i>Page Down Tool Button</i>	77
4	THE PLOTREFA™ MODULE	78
4.1	FILE MENU	78
4.1.1	<i>Open Plotrefa File (Traveltime Data and Velocity Model)</i>	79
4.1.2	<i>Append Plotrefa File</i>	80
4.1.3	<i>Save Plotrefa File</i>	82
4.1.4	<i>Open .bpk Files (Field First Breaks)</i>	83
4.1.5	<i>Open .pik files (SIPT2 First Breaks)</i>	84
4.1.6	<i>Open .lpk Files (SIPQC Output)</i>	84
4.1.7	<i>Import Elevation Data File</i>	84
4.1.8	<i>Open Borehole Data File</i>	86
4.1.9	<i>Save Traveltime Curves (DXF Format)</i>	86
4.1.10	<i>Save Velocity Model (DXF Format)</i>	87

4.1.11	Save velocity file as the Surfer™ format (.txt)	87
4.1.12	Save analysis result as text format (.txt)	88
4.1.13	Print	89
4.1.14	Print Preview	89
4.1.15	Page Setup	90
4.1.16	Exit Program.....	91
4.2	TRAVELTIME CURVE MENU.....	92
4.2.1	Exit Edit Mode	92
4.2.2	Modify Traveltimes (All Shots)	94
4.2.3	Modify Traveltimes (Individual Shot Only)	96
4.2.4	Shift a Traveltime Curve.....	96
4.2.5	Calculate Traveltime Difference Curve	97
	Audio/video clip of Difference-time Curve Calculation	98
4.2.6	Check Reciprocal Traveltime.....	98
4.2.7	Correct Reciprocal Time Automatically.....	99
4.2.8	Connect Common Source Traveltime Curves	101
4.2.9	Delete a Traveltime.....	105
4.2.10	Correct Traveltime Curve For Shot Offset	105
4.2.11	Display.....	107
4.2.12	Common Source <-> Common Receiver.....	111
4.2.13	Reverse Survey Line.....	113
4.3	VELOCITY MODEL MENU	114
4.3.1	Define Bottom Layer	115
4.3.2	Plot Velocity Labels [.....	117
4.3.3	Set Location of Velocity Labels.....	118
4.3.4	Highlight Velocity Labels [.....	119
4.3.5	Color Shading [.....	120
4.3.6	Color <-> Monochrome [.....	125
4.3.7	Automatic Contour Interval [.....	126
4.3.8	Manual Contour Interval	126
4.3.9	Show Cell Boundaries [.....	127
4.3.10	Show Layer Boundaries [.....	127
4.3.11	Show Sources [.....	129
4.3.12	Axis Title (Elevation or Depth).....	129
4.3.13	Reverse Legend [.....	129
4.3.14	Modify Layer Boundary (Point by Point)	131
4.3.15	Modify Layer Boundary (by Segment)	131
4.3.16	Straighten Layer Boundary.....	133
4.3.17	Modify Velocities (by Mouse)	133
4.3.18	Modify Velocities (by Dialog Box).....	135
4.3.19	Exit Edit Mode	135
4.3.20	Enable Surface Topography Modification [.....	136
4.3.21	Smooth.....	137

4.3.22	<i>Extend Velocity Model to Remote Sources</i>	139
4.3.23	<i>Modeling</i>	145
4.3.23.1	<i>Generate New Velocity Model</i>	146
4.3.23.2	<i>Add Random Noise to Traveltime Data</i>	147
4.3.23.3	<i>Convert Synthetic Data to “Observed” Data</i>	148
4.4	<i>VIEW MENU</i>	151
4.4.1	<i>Axis Configuration (Manual)</i>	151
4.4.2	<i>Axis Configuration (Automatic) [</i>	152
4.4.3	<i>Apply Custom Axis Configuration</i>	152
4.4.4	<i>Save Current Axis Configuration</i>	152
4.4.5	<i>Show Traveltime Curves [</i>	153
4.4.6	<i>Show Velocity Model [</i>	153
4.4.7	<i>Show Time-term [</i>	153
4.4.8	<i>Show Raypath [</i>	153
4.4.9	<i>Scale</i>	155
4.5	<i>TIME-TERM INVERSION MENU</i>	156
4.5.1	<i>Assign Layer 2 Arrivals</i>	157
4.5.2	<i>Assign Layer 3 Arrivals</i>	159
	<i>Audio/video clip of Layer Assignments</i>	160
4.5.3	<i>Do Time-term Inversion</i>	161
4.5.4	<i>Clear Layer Assignment</i>	161
4.6	<i>RECIPROCAL METHOD MENU</i>	162
4.6.1	<i>Layer Assignment</i>	165
4.6.2	<i>Set up T' (1/2T_(ab) calculated automatically) [</i>	165
	<i>Audio/video clip of Setting up T'</i>	166
4.6.3	<i>Set up T' (1/2T_(ab) set manually)</i>	167
4.6.4	<i>Delete All T' Curves</i>	167
4.6.5	<i>Show ½ T_(ab) Line [</i>	167
4.6.6	<i>Set Velocity Line</i>	168
	<i>Audio/video clip of Setting Velocity Line</i>	169
4.6.7	<i>Adjust Velocity Line</i>	170
4.6.8	<i>Decimal Places of Velocity Label</i>	172
4.6.9	<i>Delete All Velocity Lines</i>	172
4.6.10	<i>Calculate Delay Times</i>	172
	<i>Audio/video clip of Delay Time Determination</i>	177
	<i>Audio/video clip of Reverse-shot Delay Time Determination</i>	179
	<i>Audio/video clip of Entire Delay Time Calculation Process</i>	179
4.6.11	<i>Modify Delay Time (Times)</i>	180
4.6.12	<i>Modify Delay Time (Velocities)</i>	180
4.6.13	<i>Calculate Velocity Model From Delay Time Data</i>	181
4.7	<i>RAYTRACING MENU</i>	185
4.7.1	<i>Execute</i>	185
4.7.2	<i>Delete Theoretical Traveltimes</i>	186

4.7.3	<i>Show RMS Error</i>	186
4.8	TOMOGRAPHY.....	186
4.8.1	<i>Generate Initial Model</i>	188
4.8.2	<i>Inversion (With Default Parameters)</i>	190
4.8.3	<i>Convert into Layered Model</i>	192
4.8.4	<i>Inversion (Set Parameters Manually)</i>	193
4.9	OPTIONS MENU.....	197
4.9.1	<i>Dimension size</i>	197
4.9.2	<i>Units [</i>	198
4.9.3	<i>Edit Title</i>	198
4.10	ADDITIONAL TOOL BUTTONS.....	198
4.10.1	<i>Scroll Tool Buttons:</i>	198
5	APPENDICES	202
5.1	APPENDIX A - FUNDAMENTALS OF SEISMIC REFRACTION	202
5.2	APPENDIX B - THE TIME-TERM METHOD	217
5.3	APPENDIX C - THE RECIPROCAL TIME METHOD	221
5.4	APPENDIX D - THE TOMOGRAPHIC METHOD	232
5.5	APPENDIX E - RECOMMENDED READING	255

1 Introduction

Welcome to SeisImager/2DTM! SeisImager/2D is an easy-to-use, yet powerful program that allows you to:

- Read in and display your refraction data.
- Control how your data is displayed.
- Make changes/corrections to your data files and save them.
- Pick first breaks and save them.
- Invert your data for a velocity section.
- Output a travel-time plot, velocity section, and other graphics.

SeisImagerTM is the master program that consists of four modules for refraction and surface wave data analysis. The individual modules are PickwinTM, PlotrefaTM, WaveEqTM, and GeoPlotTM. The Surface Wave Analysis WizardTM is not a separate module but automatically calls on specific functions from Pickwin, WaveEq, and GeoPlot.

Pickwin and Plotrefa are the modules used for refraction analysis, making up the program called SeisImager/2DTM. Pickwin is the first break picking module and Plotrefa is the main analysis program. Though we touch on some refraction theory in this manual, this is not meant to be a treatise on seismic refraction. It is assumed that the user has a reasonable grasp of the main principals of seismic refraction, especially those behind the specific analysis techniques employed by this software. Please see the recommended reading list (Appendix E) for some good primers on seismic refraction theory and inversion techniques.

SeisImager/2D is a very powerful refraction package. It offers three separate inversion techniques: the time-term method, the reciprocal method, and tomography. Both the time-term and reciprocal methods are based on “delay times” (see Appendix C for a discussion of this all-important concept). The main difference between the two is the method by which the delay times are calculated. In the time-term method, the delay times are calculated automatically (via a linear least-squares inversion technique). In the reciprocal time method, the delay times are calculated manually. Each technique is different, and which technique you should use depends on the goals of the survey and the character of the data. SeisImager/2D also contains many ancillary tools that we hope you will find useful.

[Section 2](#) describes the software installation process. [Section 3](#) describes the process of picking first breaks with Pickwin. [Section 4](#) describes in detail the various inversion techniques available in Plotrefa. Appendix [A](#) provides an overview of seismic refraction theory. Appendices [B](#), [C](#) and [D](#) describe some

of the particulars of the three inversion algorithms. Appendix [E](#) provides a list of references for further reading on seismic refraction. A separate booklet of examples, *SeisImager/2D Examples*, is available for download on our ftp site at <ftp://geom.geometrics.com/pub/seismic/SeisImager/>. Please visit our site often for manual updates and free updates of the software.

Although this manual can be printed, it was designed as an online resource. It will be updated on a semi-regular basis, and a current version will always be available for download on our ftp site. Be sure to display the bookmarks in your PDF reader to simplify navigation. There are embedded audio/video clips that you may find useful (be sure to turn up the volume). The manual makes liberal use of color, so if you elect to print it, using color is highly recommended.

Finally, we are very interested in your constructive criticism of both this manual and the software itself. Please contact us at seismicsales@mail.geometrics.com with any comments you might have.

Note: All screens in this manual were captured in Windows XP Home Edition. If you are running a different version of Windows, some dialog boxes may look slightly different than they appear here.

2 Installing the Software

The SeisImager software CD is supplied (1) for trial evaluation of the programs, (2) for purchase, rental, or upgrade of one of the programs, or (3) with purchase of an ES-3000, SmartSeis ST, Geode, or StrataVisor NZ seismograph, which all include the Lite version of SeisImager/2D. The single CD contains all programs and all documentation. Occasionally, there will be a software release in between CD releases. In this situation, the CD will be labeled with a notice to refer to the [SeisImager website](#) to download the latest version.

SeisImager is recommended for Windows XP Home or Professional but is compatible with all versions of Windows up to Vista. Note that you must have Administrator rights to install the software. After installation by an Administrator, users with lower level privileges can use the software.

1. To install the software, insert the SeisImager CD into the CD drive. The contents of the CD will be listed as shown below.

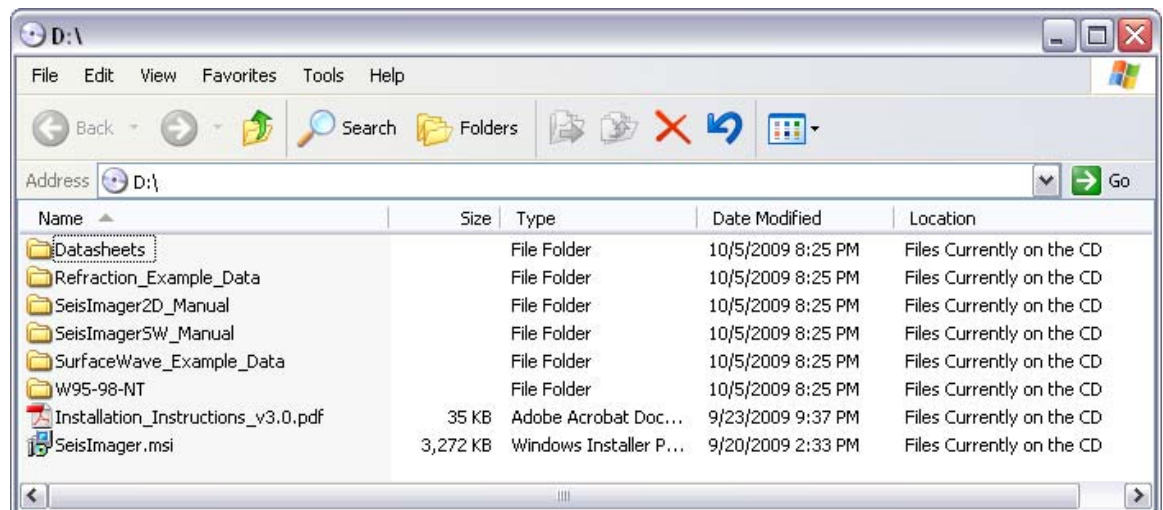

2. Double-click on the file named SeisImager.msi (or SeisImager_1009.msi) to install the software. The Welcome to the SeisImager Setup Wizard window will appear as follows.

- a. **If you are presented with the option to *Repair SeisImager* or *Remove SeisImager* as shown below, the installer has detected an older version. Select *Remove SeisImager* and click on *Finish*, then *Close* after the **uninstall process is complete**. Double-click again on the file SeisImager.msi to install the new version as described in Step 2b.**

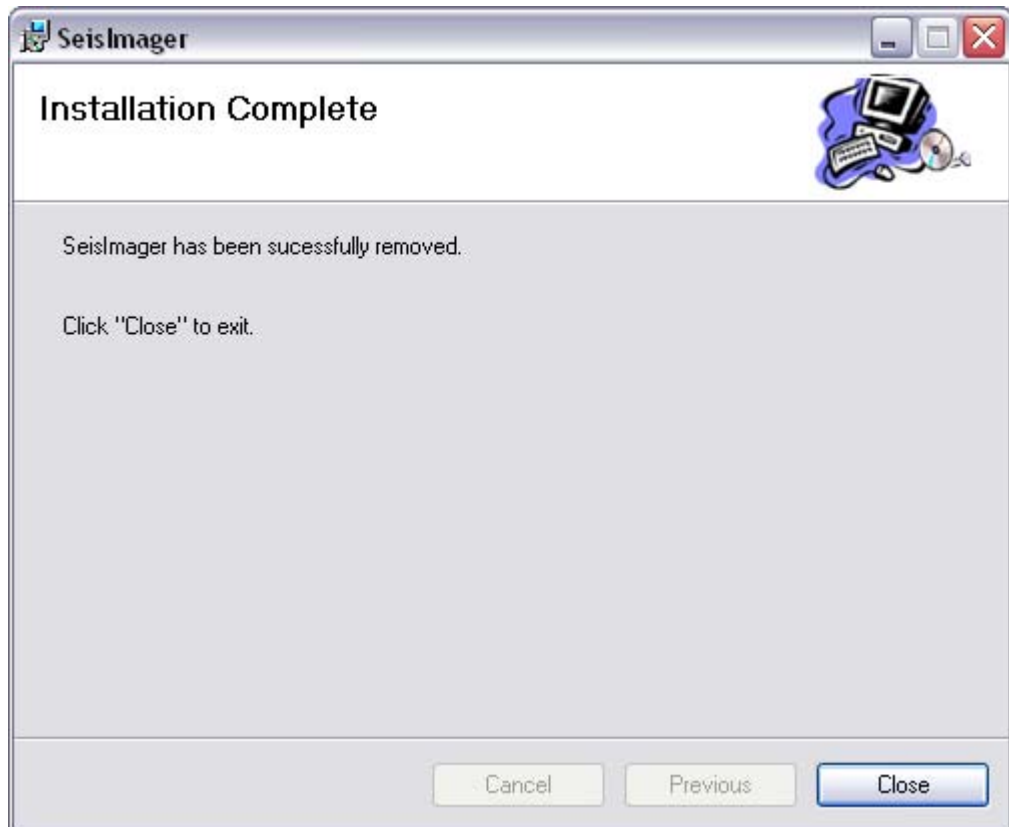

- b. **If an older version is not detected**, you will be presented with the installer as shown below. Click on *Next*, indicate the directory for installation (the default directory is recommended), click on *Next*, *Next*, and *Close*. It is not necessary to reboot the PC after completing the installation.



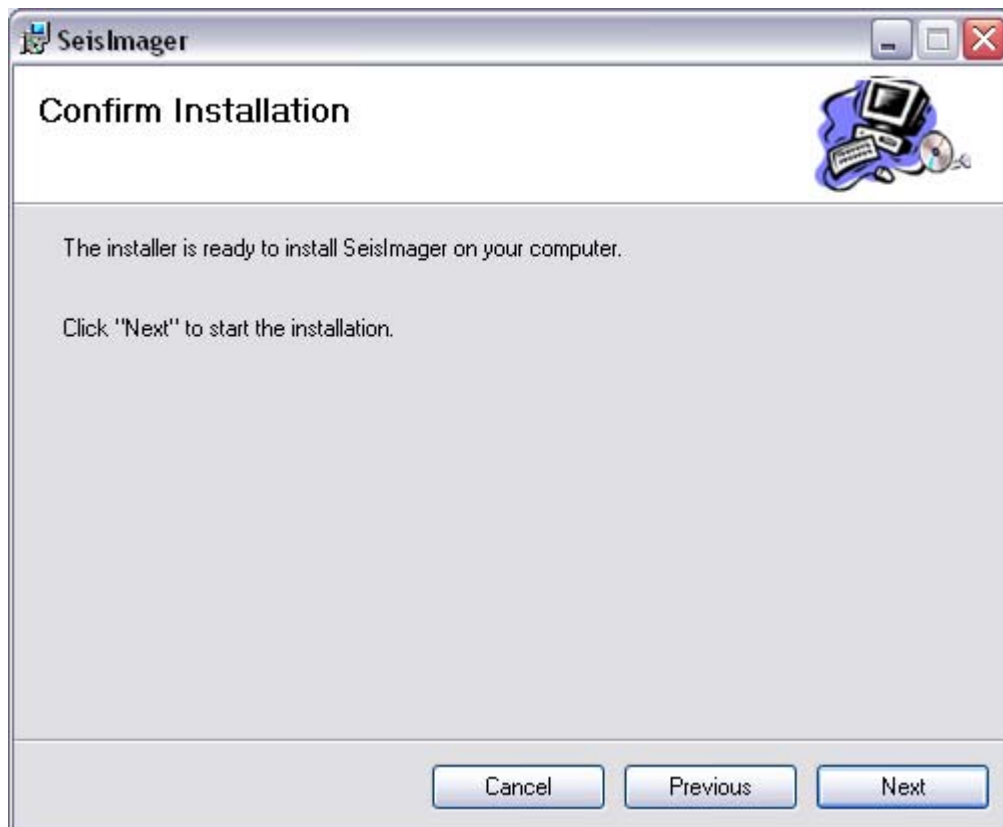

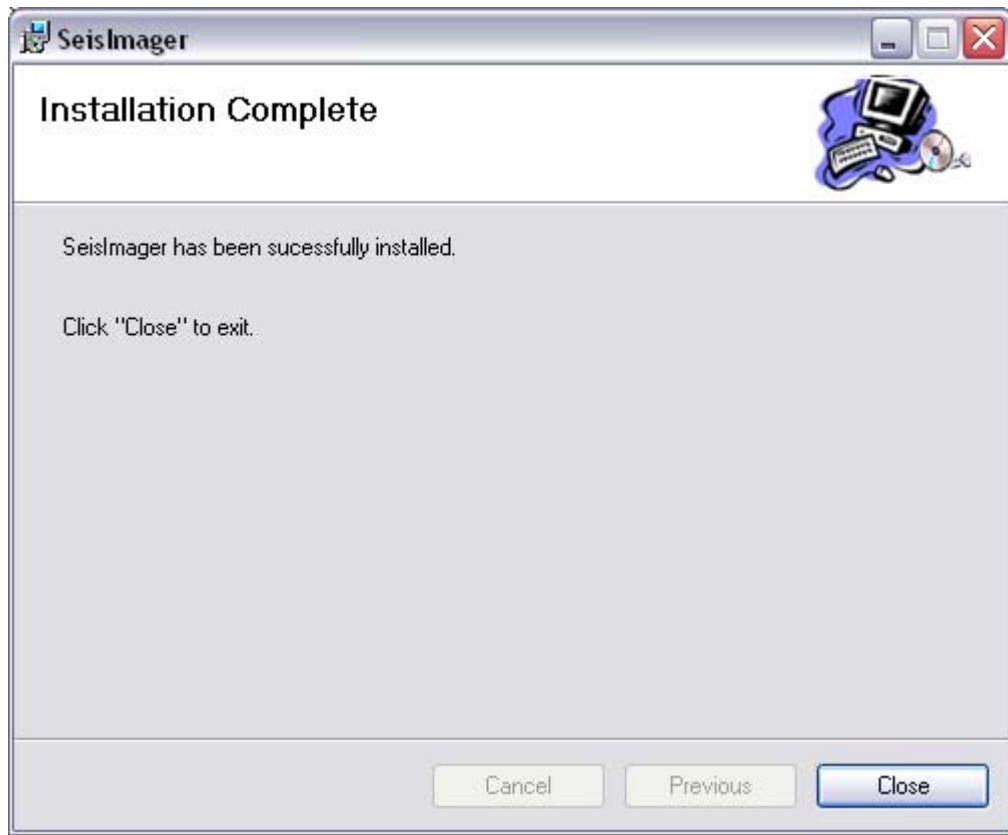

3. To copy the SeisImager manuals to your hard drive (~125 MB), select the folders SeisImager2D_Manual and SeisImagerSW_Manual on the CD and copy them to your hard drive in the desired location. Note that the SeisImager2D_Manual folder contains .avi video clips that must reside in the same location as the files SeisImager2D_Manual_vX.X.pdf and SeisImager2D_Examples_vX.X.pdf (where X.X is the current version).

You will need Adobe's freeware program Acrobat Reader to view the manual files. If you need this program, go to the Adobe website to download the latest version compatible with your operating system.

4. To register the software, go to the *Start* menu, under *All Programs*, *SeisImager* to find the SeisImager Registration program as shown below. **If you are using the software on a trial basis in demonstration mode, skip to Step 5.** Open the register and email the keyword shown to support@geometrics.com with your order number and seismograph serial number (if you purchased the software with a seismograph) and we will reply with a registration password to enable the version of the software you have purchased. Once received, enter the password into the password field and click *OK*.



The programs enabled by the password will be reported in a series of messages. For example, as shown below, for purchase of SeisImager/2D Standard and SeisImager/SW-2D, the register reports that SeisImager/2D Standard, SeisImager/SW-2D, and GeoPlot Standard are registered. Click *OK* to accept each message.

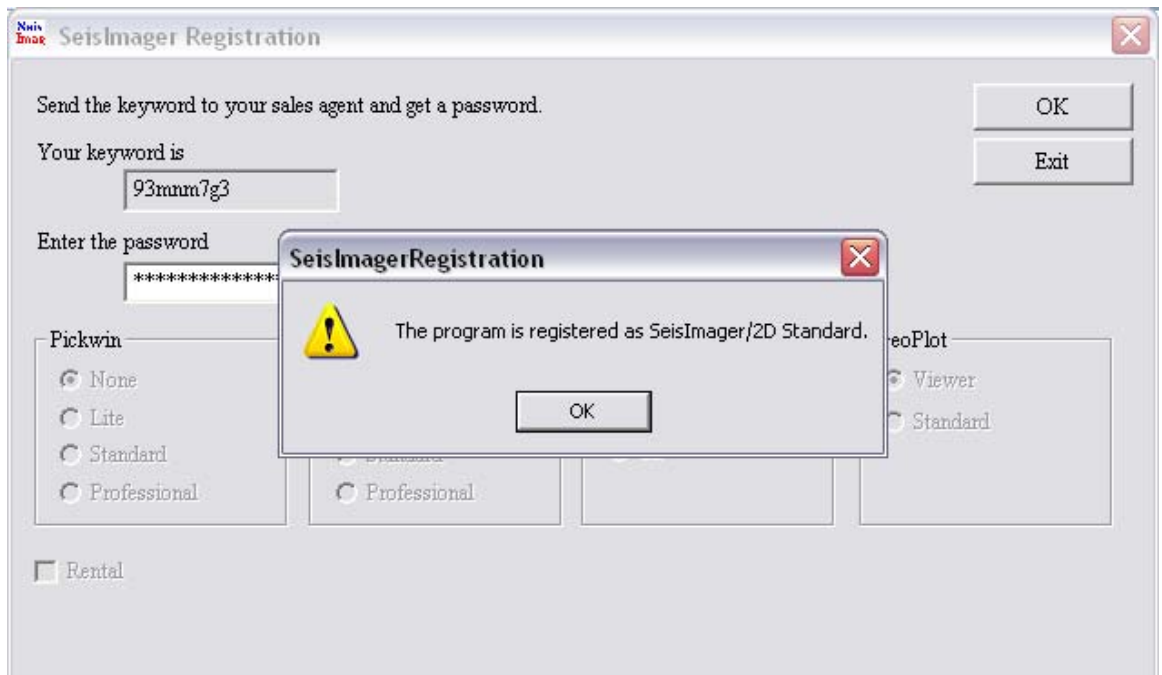

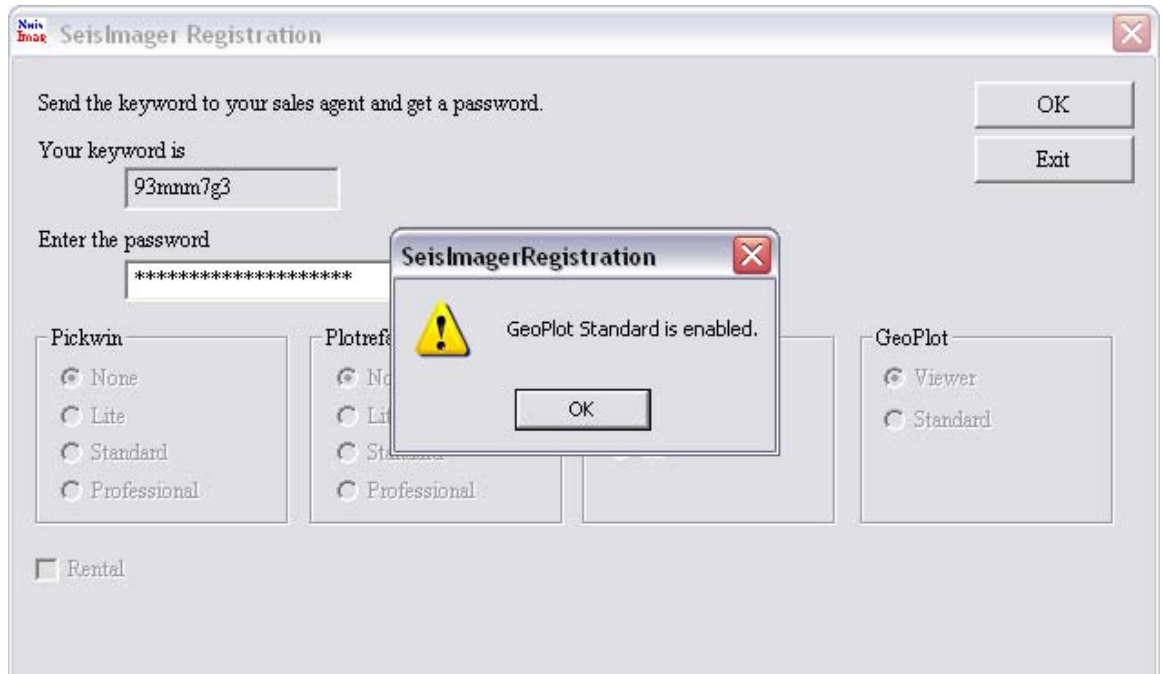
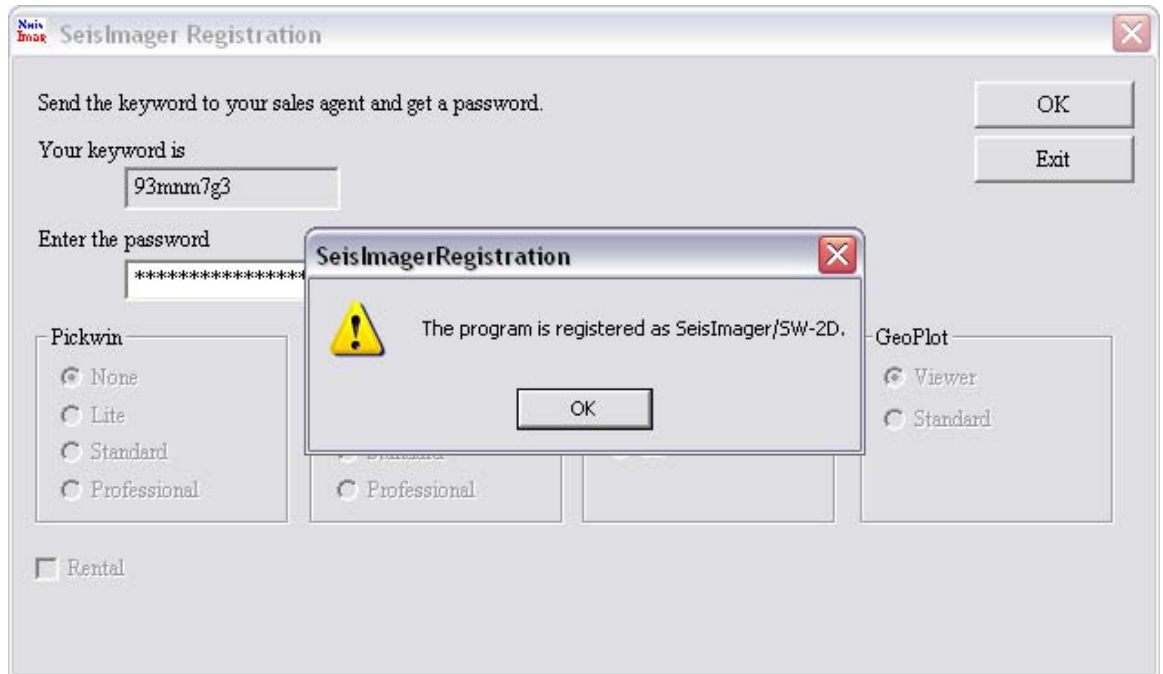

After these messages have appeared, the register will also reflect the programs that have been registered, as shown below.

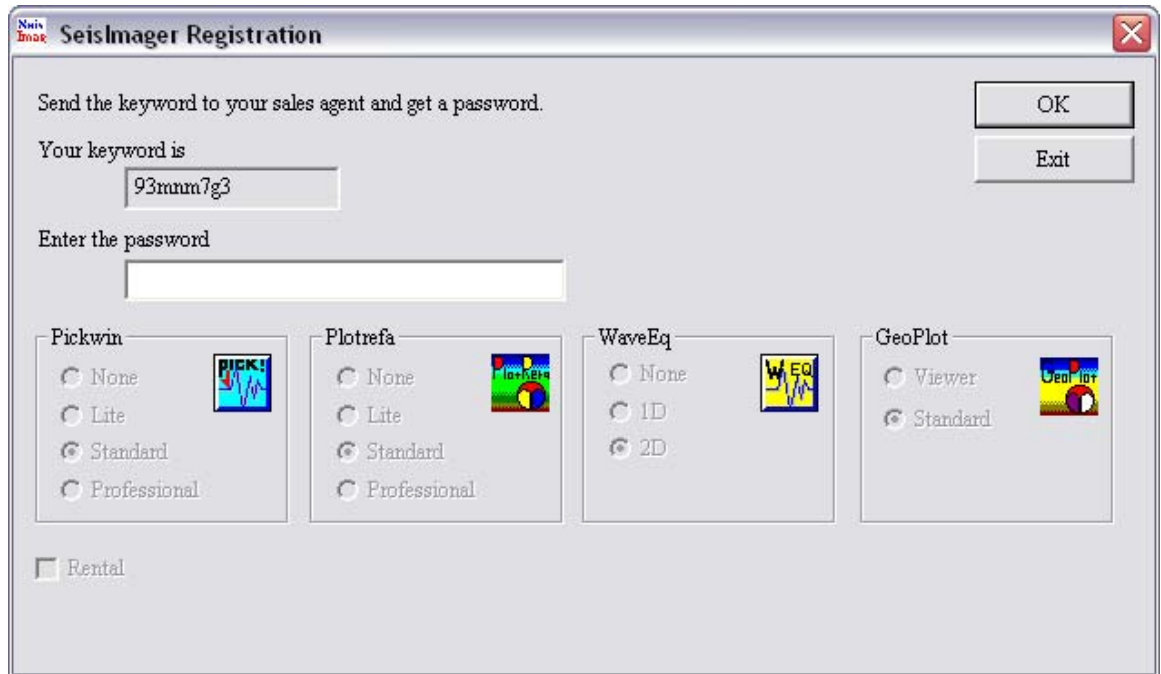

Typically, installing an upgrade of the software does not require re-registration, but if you are upgrading from a version older than April 2007, you will need to re-register.

5. Once installed, the program modules can be opened directly through the desktop icons shown below or through the links in the *SeisImager Start* menu folder.

SeisImager/2D consists of the Pickwin and Plotrefa modules.
 SeisImager/SW-1D consists of the Pickwin and WaveEq modules.
 SeisImager/SW-2D consists of the Pickwin, WaveEq, and GeoPlot modules.
 The Surface Wave Analysis Wizard is not a separate module but automatically calls on specific functions from Pickwin, WaveEq, and GeoPlot to walk you through the analysis process. All of the icons will be shown regardless of which program(s) have been purchased or will be used.

To begin using the software, double-click the Pickwin module icon. If you have installed for the first time or upgraded from a version older than April 2007, a prompt will ask you to set the language as shown below. Choose *English*.

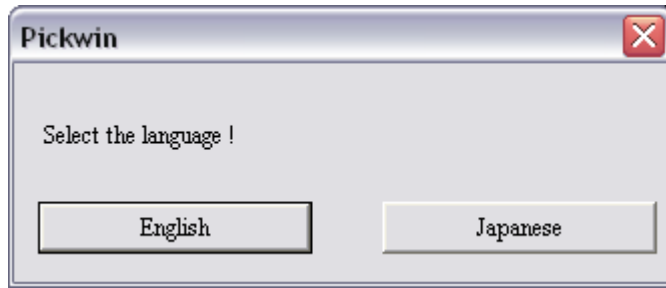

For registered installations, upon selection of the language, the module opens and is ready for use. As well, the other registered modules are ready for use. For unregistered installations running in demonstration mode, proceed to Step 6.

6. If you are using the software in demonstration mode, after selecting the language you will be presented with the registration dialog box as shown below. Leave the password field empty and click *OK*.

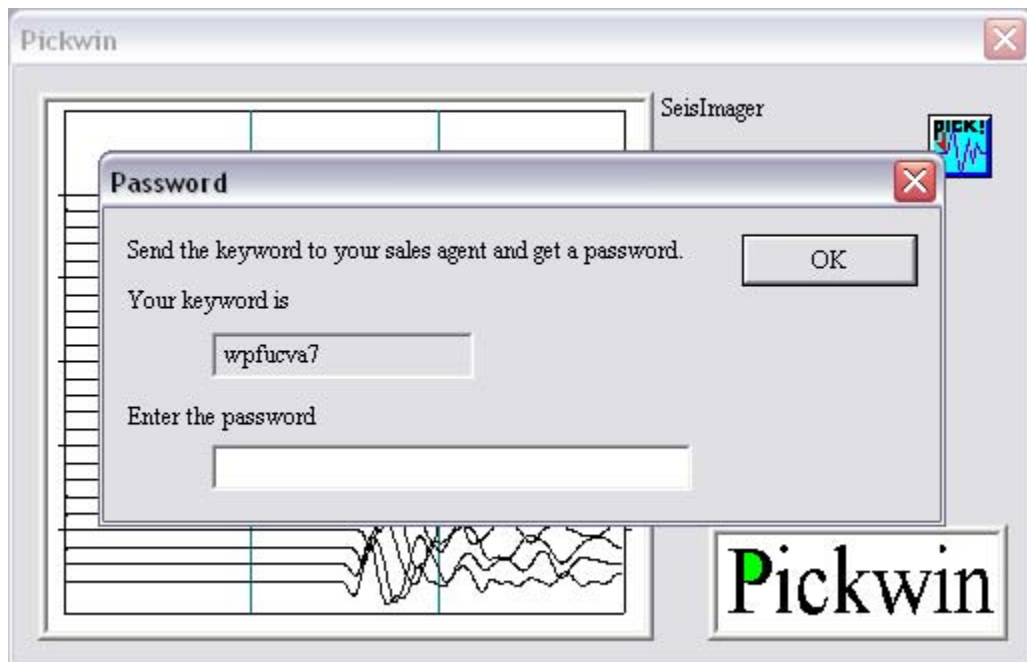

Detection of no password and the number of available run-times will be reported as shown below. Click *OK*.

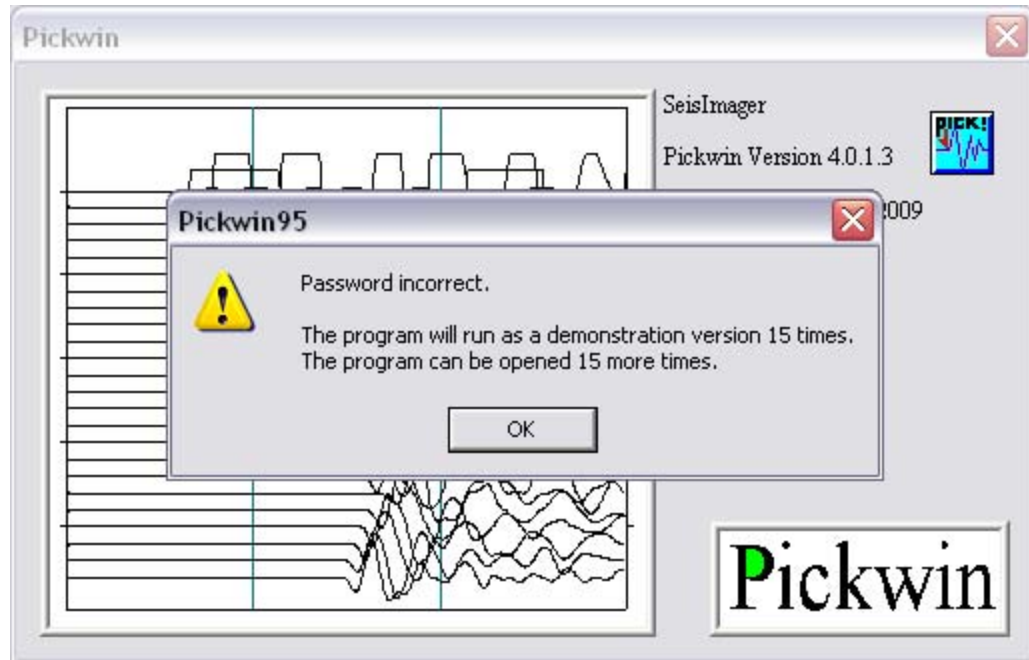

After running the software in demonstration mode, if you later purchase the software, refer to Step 7 on how to enter your registration password.

7. To enter your password after running the software in demonstration mode, go to the *Start* menu, under *All Programs*, *SeisImager* to find the SeisImager Registration program as shown below. Open the register and email the keyword shown to support@geometrics.com with your order number and seismograph serial number (if you purchased the software with a seismograph) and we will reply with a registration password to enable the version of the software you have purchased. Once received, enter the password into the password field and click *OK*.



Once the software is registered (refer to Step 4 for a full description of the process), the data input dimensions of the demonstration version will be updated to reflect the limits of the program purchased. Click *OK*.

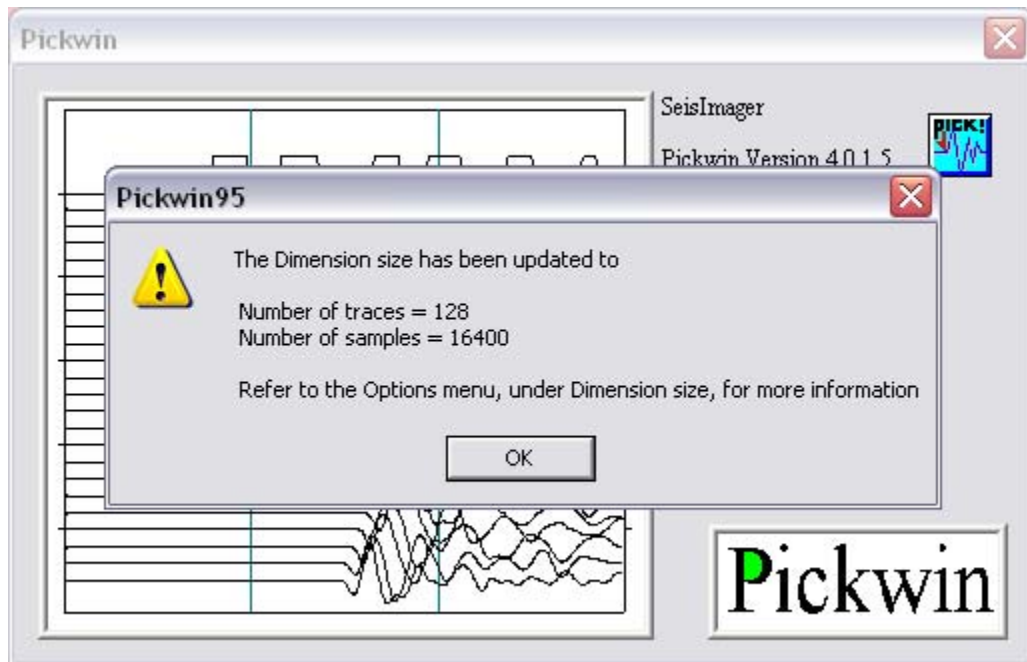

This completes the description of all possible registration pathways.

As mentioned previously, the Lite version of SeisImager/2D comes free with all seismograph purchases, so if you have purchased SeisImager/SW with a

seismograph, you are also entitled to the Lite version of SeisImager/2D. If you do not already have a license of SeisImager/2D, Lite or otherwise, but would like to order a copy, please contact us at seismicsales@geometrics.com or support@geometrics.com.

A general recommendation when using SeisImager/2D is to close and reopen the software modules or open a second instance of the software modules to start new, separate analyses. The programs are efficient and quickly launch so this is easy to do, and will prevent complications when data processing.

Regarding making report graphics and documenting your data processing, it is handy to have a screen capture program such as HyperSnap from Hyperionics (www.hyperionics.com). Bitmap screen captures can be quickly and easily made at the desired stages of processing and saved for import to Microsoft Office or other programs.

3 The Pickwin™ Module

The main purpose of Pickwin is to help you identify your first breaks, pick them, and save them for input to the analysis program, Plotrefa. Once you have read your data in, (and edited it if necessary; see below), you may optimize the appearance of the data to enhance the appearance of the first breaks. Toward this end, you may filter the data, change the display gains, change the distance and time scales, and change the trace style, and correct the record for timing errors. Once you have optimized the data, the program will automatically pick the first breaks at the touch of a button, which you will then have a chance to adjust. After the breaks have been picked, you may save them, read in the next SEG-2 file, and repeat until all files have been picked and the picks have been saved.

After reading in your data file, as mentioned above, you may edit it. For example, you may truncate it, desample it, or change the geometry information in the header. Once you have finished editing, you may save it in the same SEG-2 format. This is a useful feature for correcting any mistakes you may have made in the field. For instance, you may have used a much longer record length than you needed, resulting in very large files. This feature would allow you to truncate the unnecessary part of the file and make the file smaller.

The general flow of Pickwin is depicted in the flow chart below.

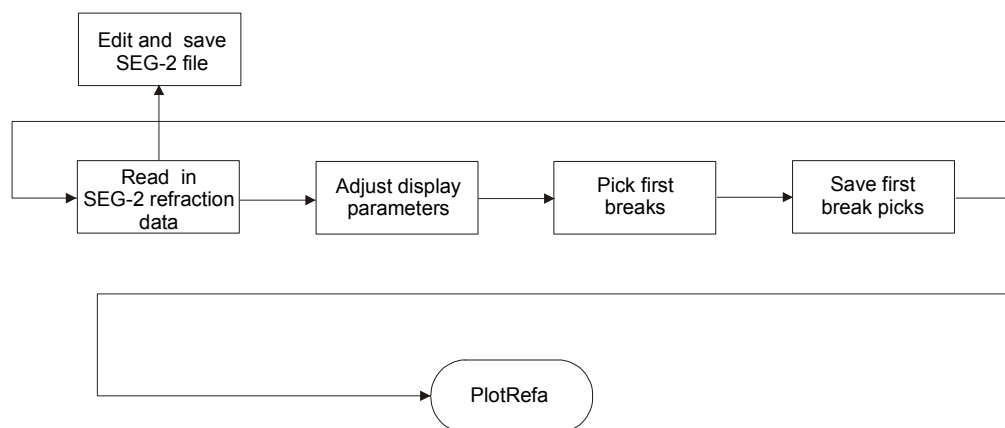

Note: Never over-write raw field data. Always save edited data with a different file name from the raw data.

Click on the shortcut to start Pickwin. You will see the following:

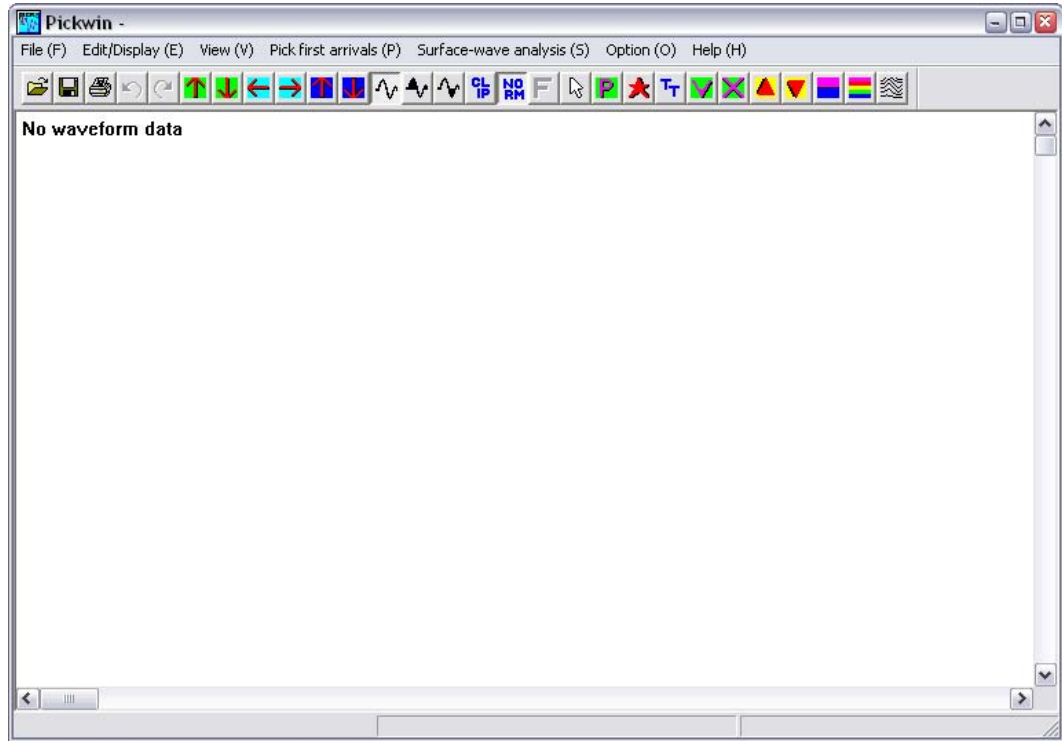

The user-interface of Pickwin consists of a series of menus along with a toolbar. We will now discuss in detail the various menus of Pickwin.

3.1 File Menu

Click on “File” to reveal the **File** menu:

3.1.1 Open SEG2 File

Click on “Open SEG2 file” or press the “Open File” tool button to read in a record. You will see the following dialog box:

Find the folder your data resides in and open it. SEG2 files from Geometrics seismographs have a “.dat” extension, so this is the default, and only “.dat” files will be displayed. Choose the file you want to read in by double clicking on it. If there are already data in memory, you will be presented with the following dialog box:

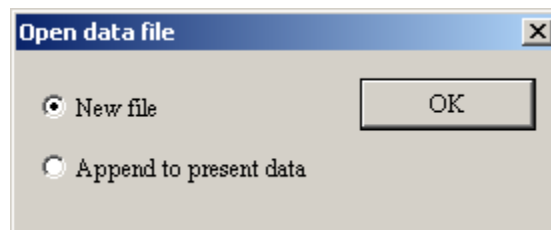

Generally you will be reading in a “new” file, but you may also append records together. The “append” option is discussed in depth in Section 3.2.8.

3.1.2 Save SEG2 File

To save a SEG2 file after editing, choose “Save SEG2 file” or press the “Save File” tool button . You will get a dialog box identical to the one above. Choose a file name and press *Save*. The extension will default to the Geometrics-standard “.dat”.

3.1.3 Open SEG2 File (SmartSeis)

This is identical to that described in 3.1.1. It is used to open SEG2 data acquired with the Geometrics SmartSeis seismograph, which is stored in a different SEG-2 format (20-bit float) than our other seismographs. The file extension is “.dat”.

3.1.4 Open McSeis-3 File

This is identical to that described in 3.1.1. It is used to open data acquired with the Oyo McSeis-3 seismograph. There is no particular file extension for McSeis files.

3.1.5 Open OYO 160MX (SEG1) file

This is identical to that described in 3.1.1. It is used to open data acquired with the Oyo 160MX seismograph. There is no particular file extension for 160MX files.

3.1.6 Open First Break Pick File

A SEG2 file must be open in order to use this feature. Click on “Open First break pick file”. You will see the following dialog box:

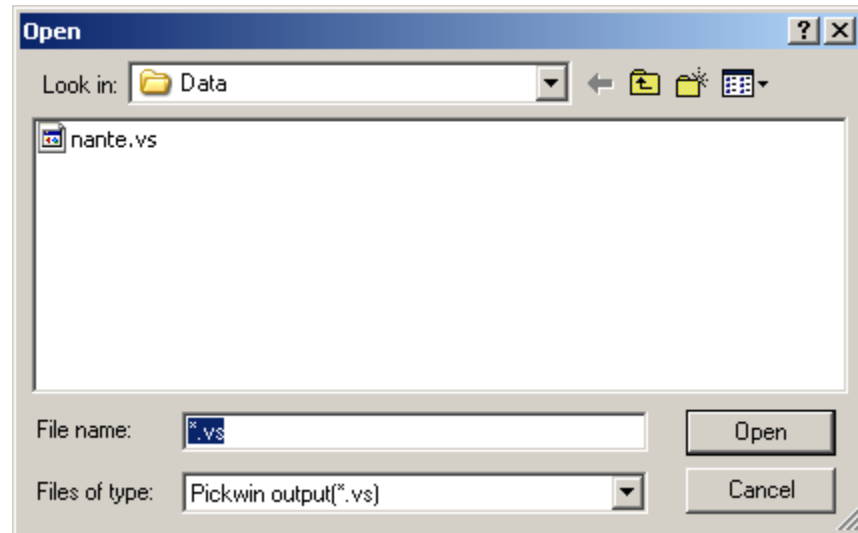

First break pick files that have been picked with Pickwin have a “.vs” extension. Choose the file you want to read in by double clicking on it.

3.1.7 Save First Break Pick File

To save traveltime curves after first breaks are picked, choose “Save first break pick file”. You will see the following dialog box:

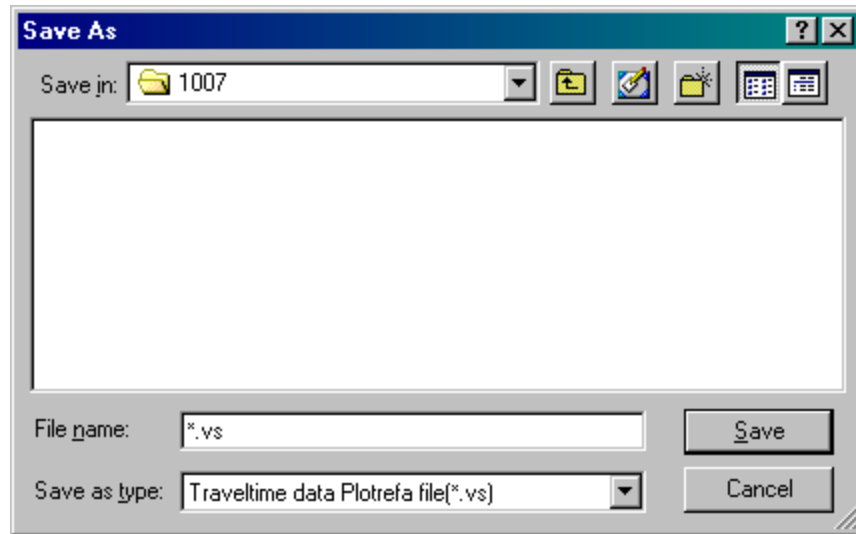

Choose a file name and press “Save”. The extension will default to “.vs”.

3.1.8 Print Window Display

To print the window display of Pickwin, choose “Print window display(P)”, **CTRL-P** , or press the “Print” tool button . You will see the print dialog box for your computer:

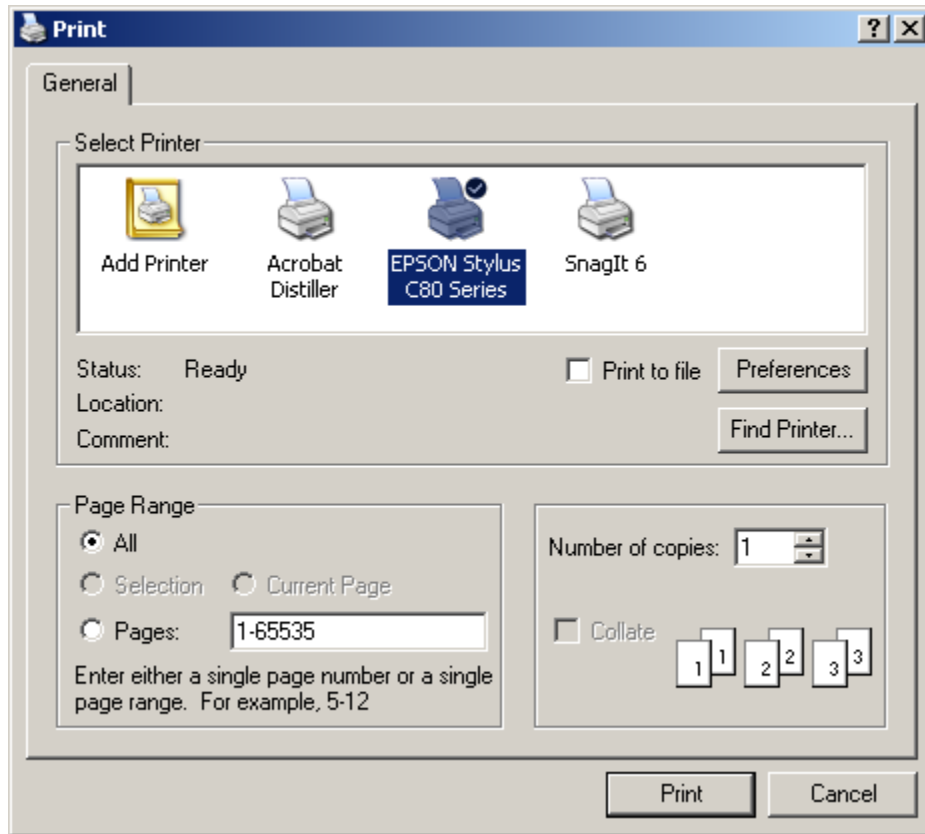

Click **OK** to print the current window display of Pickwin.

3.1.9 Print Preview

To preview the window display of Pickwin for printing, choose “Print preview(V)”. You will see a preview of the window display that will be printed:

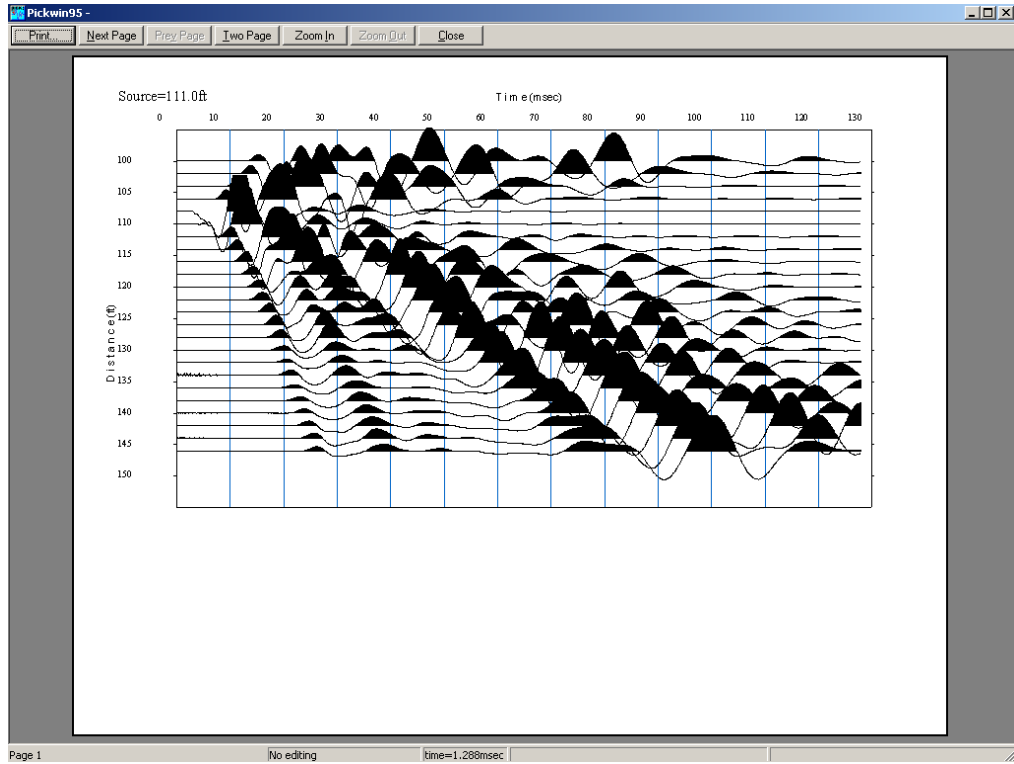

To print this display, press **Print**. To close this display, press **Close**.

3.1.10 Page Setup

To set up a page for printing, choose “Page set up(R)”. You will see the print dialog box for your computer:

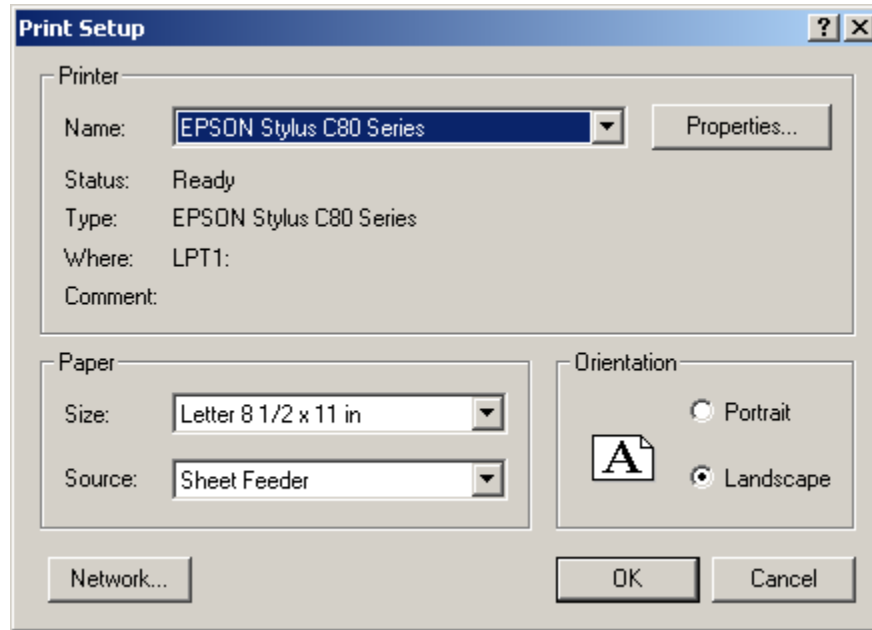

Adjust the properties for printing or click **OK** to print the current window display of Pickwin.

3.1.11 Group (File list)

It is often convenient to read in a group of shot records, rather than one at a time. The **Group (File list)** menu can be used to group files conveniently.

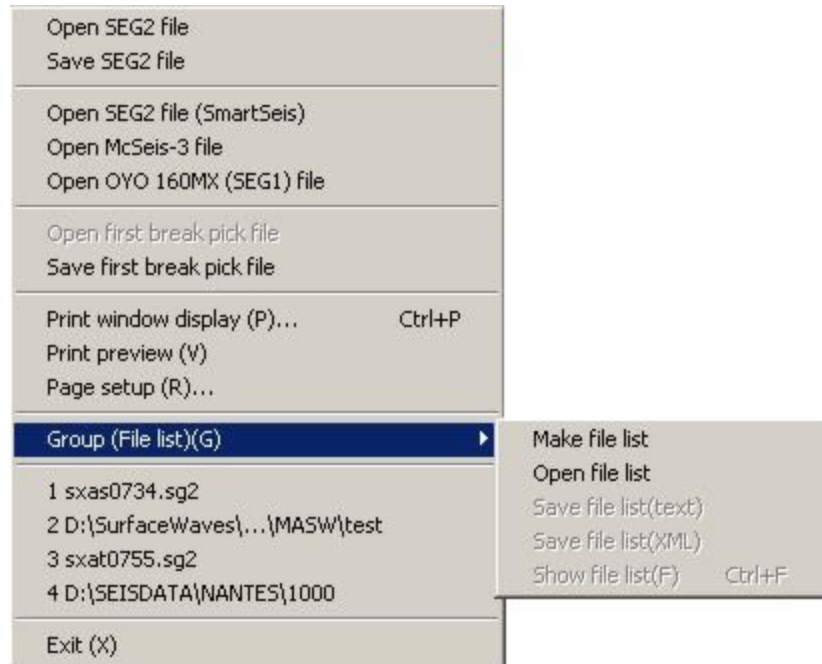

3.1.11.1 *Make File List*

To make a group, choose “Make file list” in the submenu. Choose the files you wish to group my holding down the CTRL or SHIFT key and clicking on them.

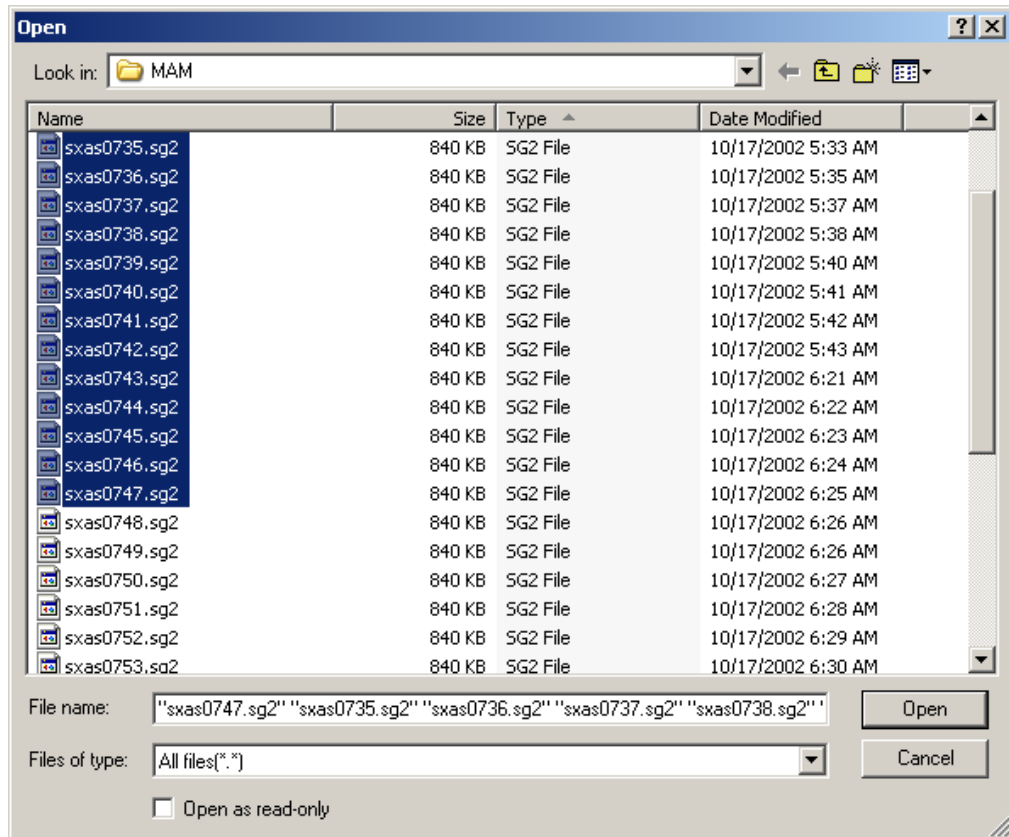

Press **Open** and you will see the following message:

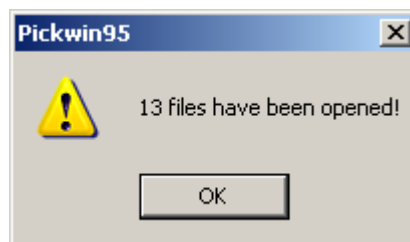

Press **OK**:

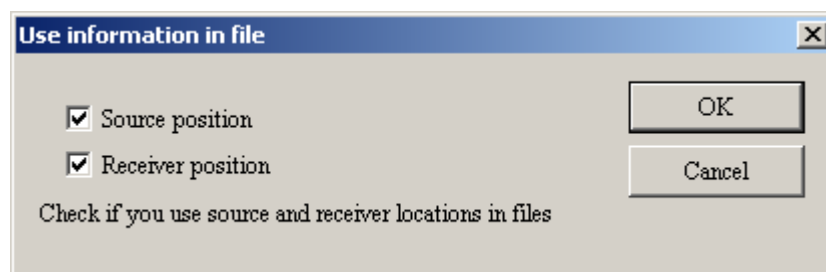

If the source and receiver positions are included in the data files, click both boxes in the above dialog box (default). The geometry will be automatically read from the file headers. The following table will then be displayed:

Index	Edit	ID	Source(m)	1st receiver(m)	Receiver int.(m)	# of aux.	
3	<input type="checkbox"/>	738	0	0	1	0	OK
4	<input type="checkbox"/>	739	0	0	1	0	Cancel
5	<input type="checkbox"/>	740	0	0	1	0	Next
6	<input type="checkbox"/>	741	0	0	1	0	Back
7	<input type="checkbox"/>	742	0	0	1	0	Set up
8	<input type="checkbox"/>	743	0	0	1	0	Set # of aux.
9	<input type="checkbox"/>	744	0	0	1	0	Delete
10	<input type="checkbox"/>	745	0	0	1	0	Number of file
11	<input type="checkbox"/>	746	0	0	1	0	13
12	<input type="checkbox"/>	747	0	0	1	0	

If you read the geometry directly from the shot file headers, then the geometry information displayed in the table should be ignored. However, this is a good place to confirm the shot records you have included in the group (see the “ID” column). If you want to delete one of the files in the group, click the appropriate box in the “Edit” column and press the **Delete** button. Press **OK** to continue

If the geometry data were *not* read from the shot file headers, this dialog box will allow you to set up the survey geometry. For each file, enter the source position, the location of the first receiver, and the receiver interval. For refraction applications, you may ignore the “# of aux” column.

Use the **Next** and **Back** buttons to scroll up and down through the shot record IDs. Ignore the **Setup** and **Set # of aux** buttons.

***Note:** The above dialog box assumes constant geophone spacings. If you have variable geophone spacings, **and** the geometry data were not recorded in the shot record files, you may enter the geometry information under “Edit source/receiver locations, etc.” in the **Edit/Display** menu. This must be done on a file-by-file basis – read in the file, fill in the geometry information, and save the file back out as a SEG-2 file. It is generally advisable to set the geometry parameters in the field and record them in the shot file headers.*

3.1.11.2 Open File List

Once you have created a group, you may save it for future retrieval in .txt or .xml format (see below). To open a group, select “Open file list”. You will be presented with the following dialog box:

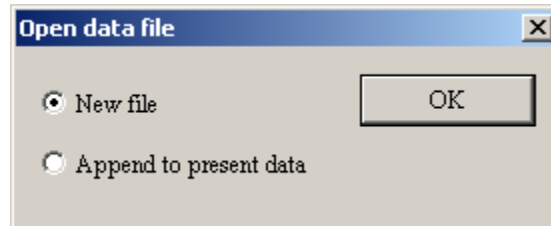

You can append file groups in the same way you can append individual files (see Section 3.2.8). Choose “New file” or “Append to present data” and press OK:

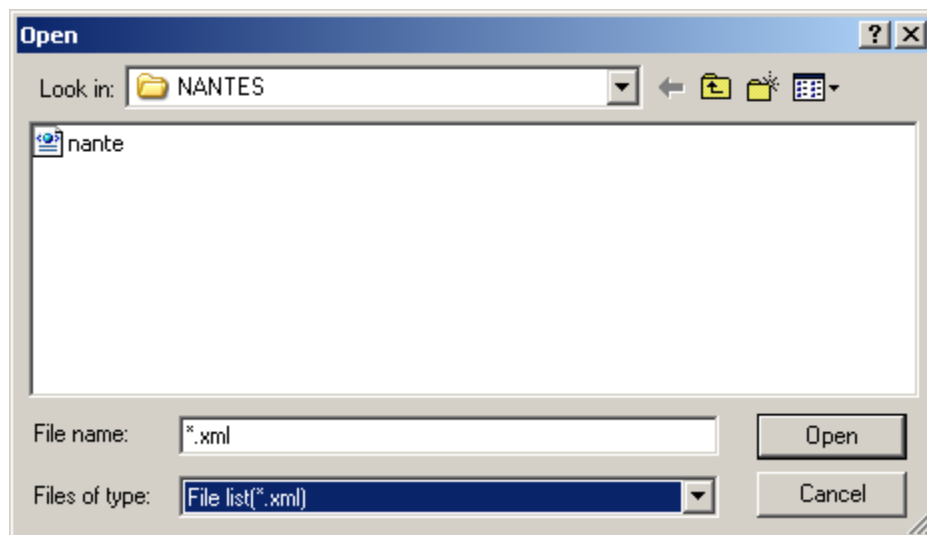

Choose the appropriate group file (the default file format is .xml).

If the file is in .xml format, you will see the geometry dialog box:

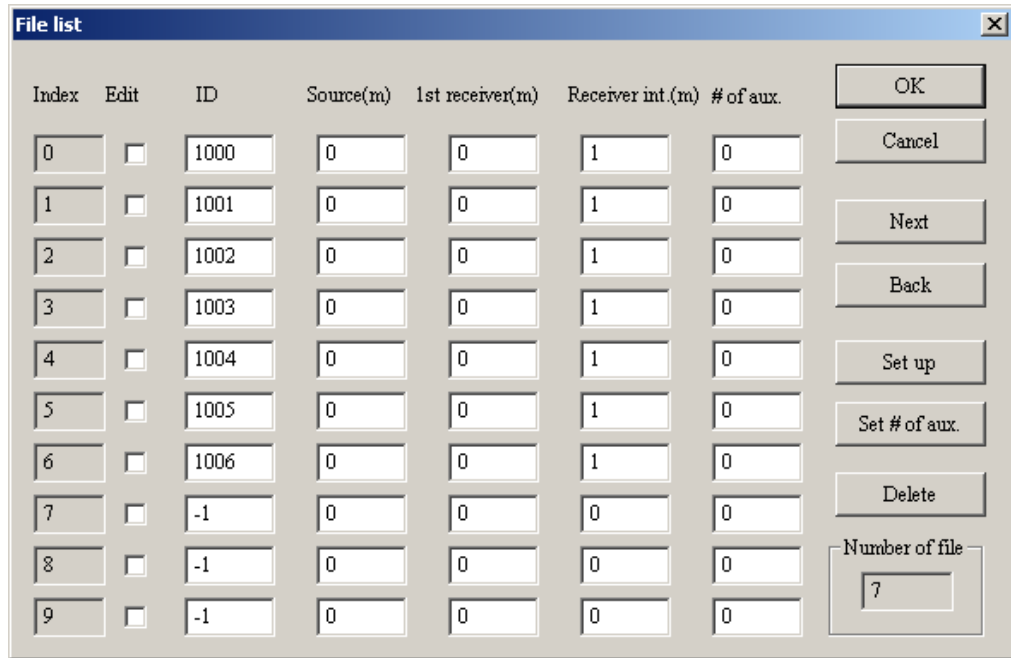

This is an opportunity to modify the geometry or to delete shot files from the group. Press **OK** to display the first shot record in the group.

If the group file is in a .txt format, you will be presented with the following dialog box:

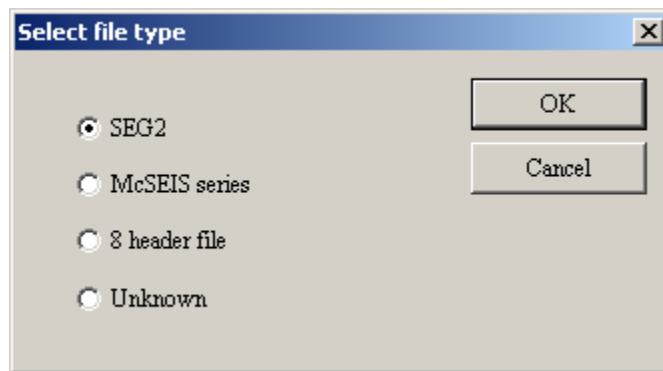

Indicate the data type and press **OK**:

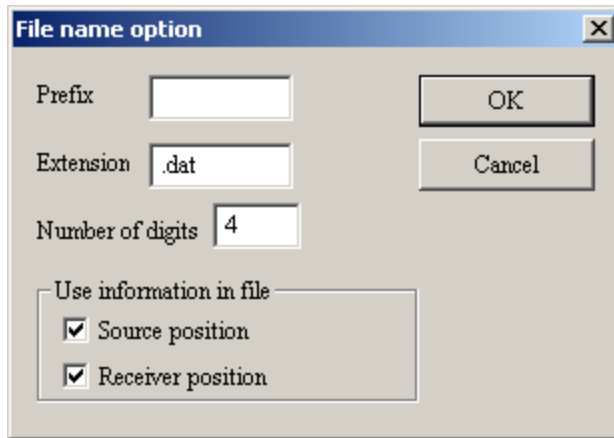

Prefix: Some seismographs put some sort of prefix before the file ID number, e.g., FILE2001.SG2. When the group file is in text format, you must enter any prefix manually. If there is no prefix (Geometrics seismographs), leave the prefix field blank.



Extension: Different seismographs use different file extensions, such as “.dat” or “.sg2”. Enter the correct extension.

Digits: Enter the number of digits in the file ID number.

Finally, indicate whether or not the source and receiver positions should be read from the file headers or not.

Press **OK**, and you be presented with the geometry menu, as above. Press **OK** again to display the first shot record in the group.

In general, .xml format tends to be the most convenient.

Once you reach the data display, you may now page through all of the shot records in the group using the  and  tool buttons. This is extremely convenient in the first break picking process.

3.1.11.3 *Save File List (text)*

Choose “Save file list (text)” to save the group as a text file.

3.1.11.4 *Save File List (XML)*

Choose “Save file list (XML)” to save the group as a .xml file.

3.1.11.5 Show File List

Select “Show file list” to display the geometry menu:

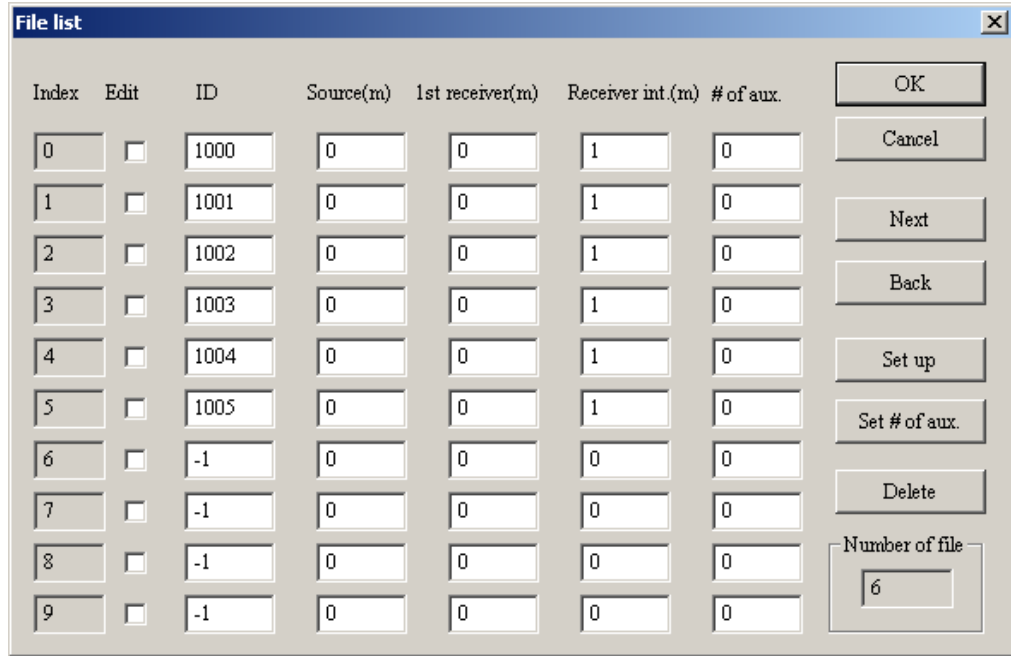

3.1.12 Last Four Files Opened

The last four files opened in Pickwin will be displayed in the **File** menu. To open any of these files, just click on the file.

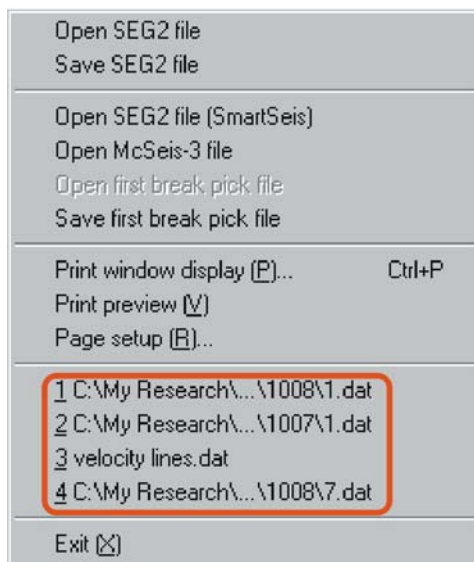

3.1.13 Exit

To exit the Pickwin module, choose “Exit (X)”. You will see the following dialog box:

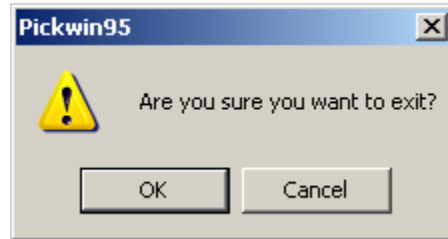

Press **OK** to exit Pickwin or press **Cancel** to continue using Pickwin.

3.2 *Edit/Display Menu*

*Note: Be sure to do any trace editing **before** picking your first breaks.*

Click on “Edit/Display” to reveal the **Edit/Display** menu:

3.2.1 Undo

To undo the last command performed, click on “Undo”. Or, press the “Undo” tool button . The last command performed by Pickwin will be undone.

3.2.2 Redo

To redo a command that was “undone”, click on “Redo”. Or, press the “Redo” tool button . The last command that was undone will now be redone.

3.2.3 Select Trace [

Certain operations can be performed on individual traces. It is therefore necessary to choose which traces you wish to perform these certain operations on. Specifically, a trace must be selected before it can be reversed in polarity, killed, or deleted. To enable individual trace selection, click on “Select trace”.

Alternatively, you may enable/disable trace selection by pressing the tool button.

Select a trace for editing by clicking on it. The trace will change from black to red when it is selected.

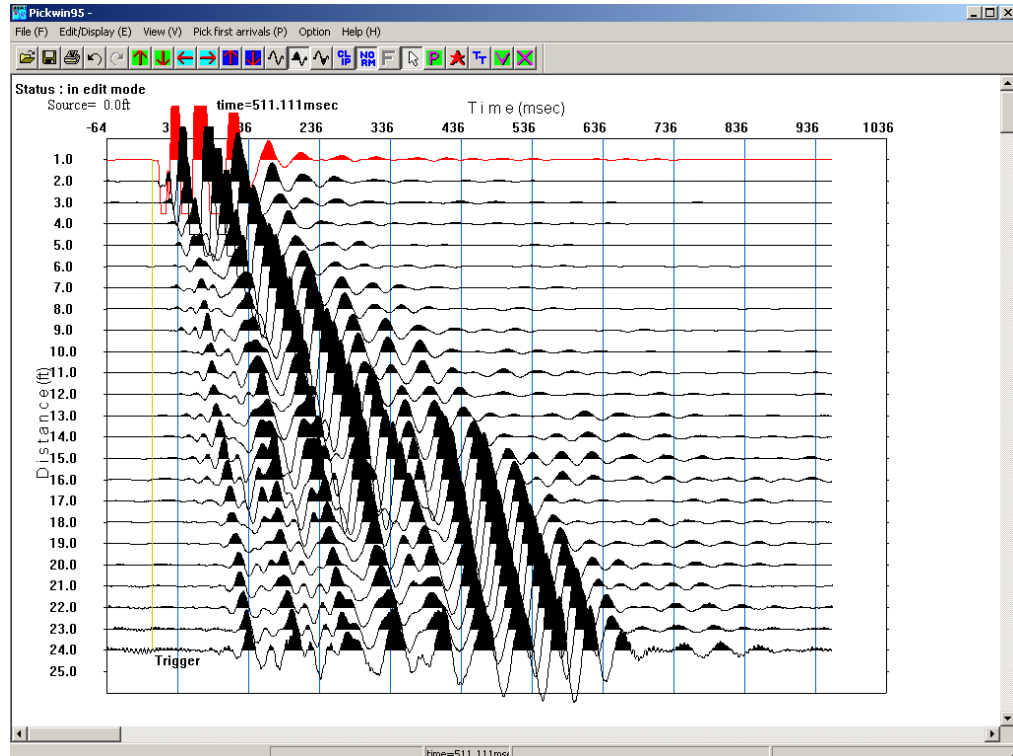

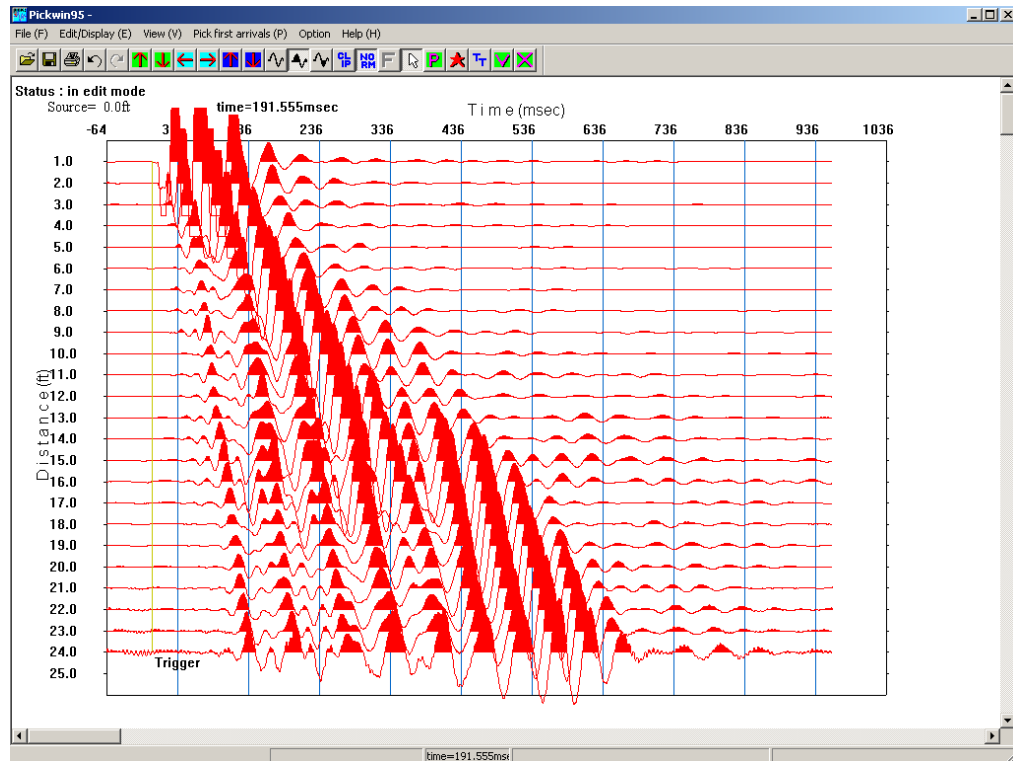

3.2.4 Select All Traces

To select all of the traces at once, click on “Select all traces”. All of the traces will turn red, and a check mark will now be displayed next to the **Select trace** menu item:

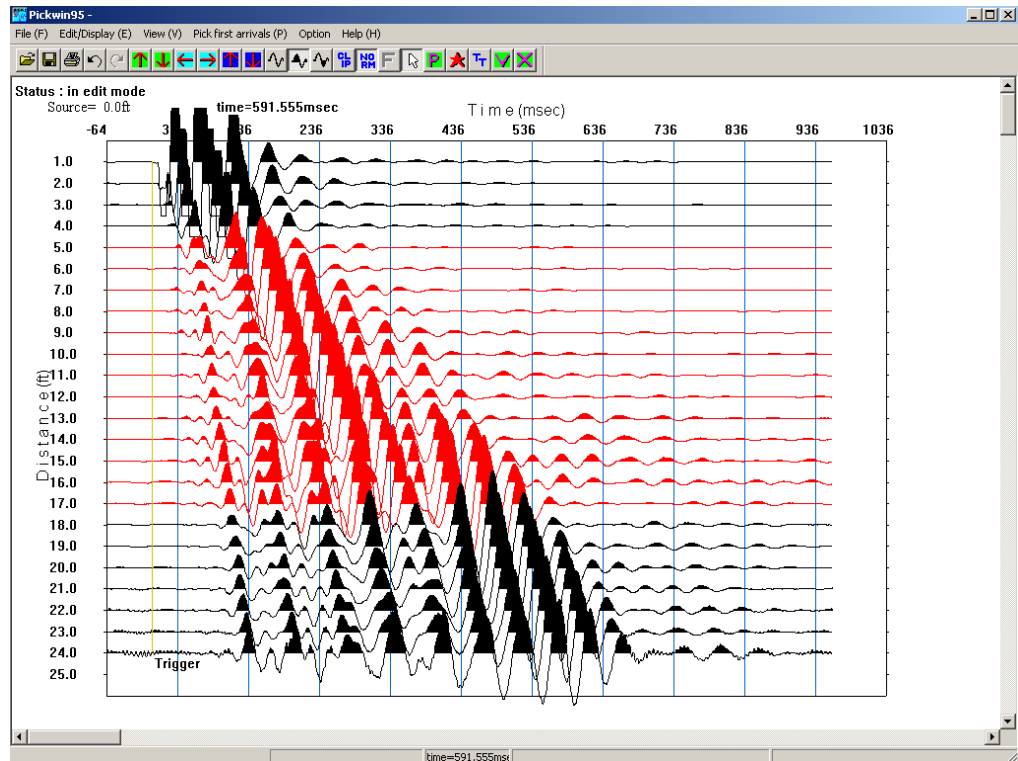

Alternatively, you can press the  button and then drag your mouse over some or all of the traces. This is a convenient way to select a group of traces:



To de-select the traces, press the  tool button, or click on “Select trace” in the **Edit/Display** menu.

3.2.5 Selected Traces

When a trace or traces are selected for editing, the selected trace(s) can have the polarity reversed, killed, or deleted:

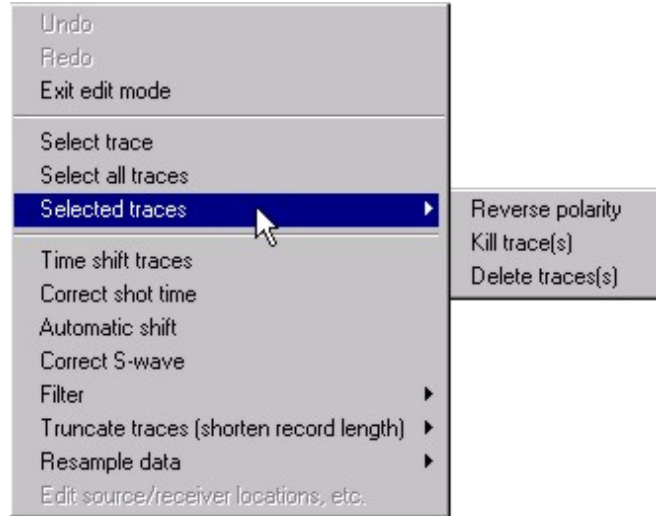

3.2.5.1 *Reverse Polarity*

To reverse the polarity of a selected trace(s), click on “Reverse polarity” from the sub-menu:

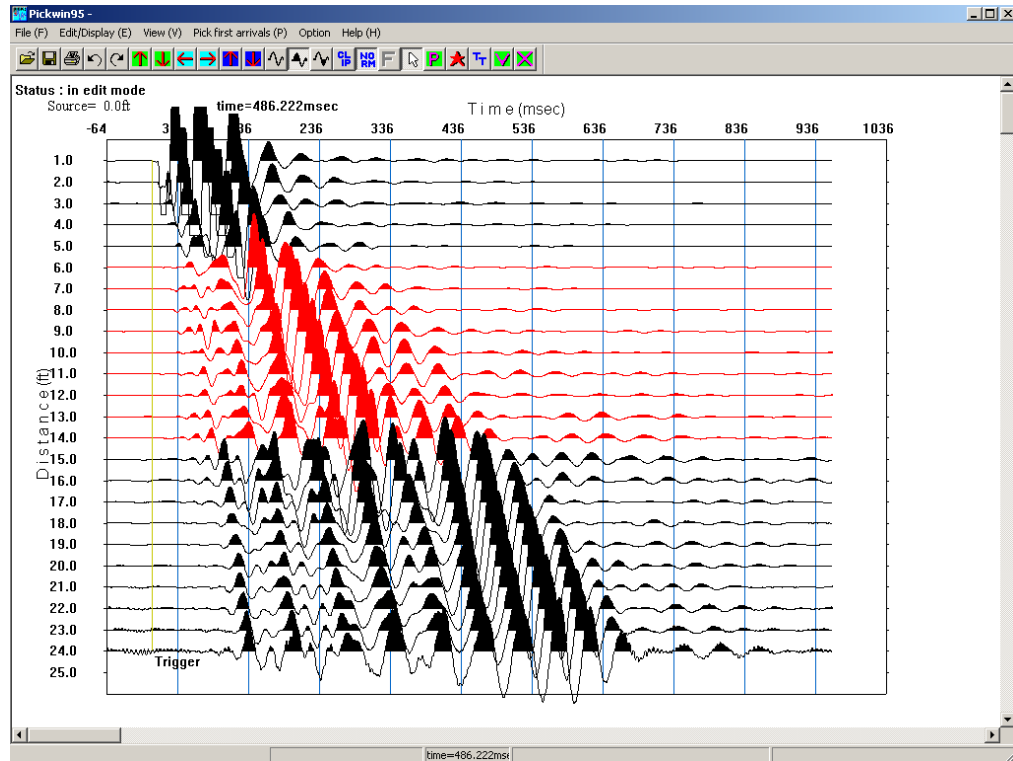

Note that the polarity of the group of traces selected earlier has now been reversed.

3.2.5.2 *Kill*

To “kill” a selected trace(s), click on “Kill trace(s)” from the sub-menu:

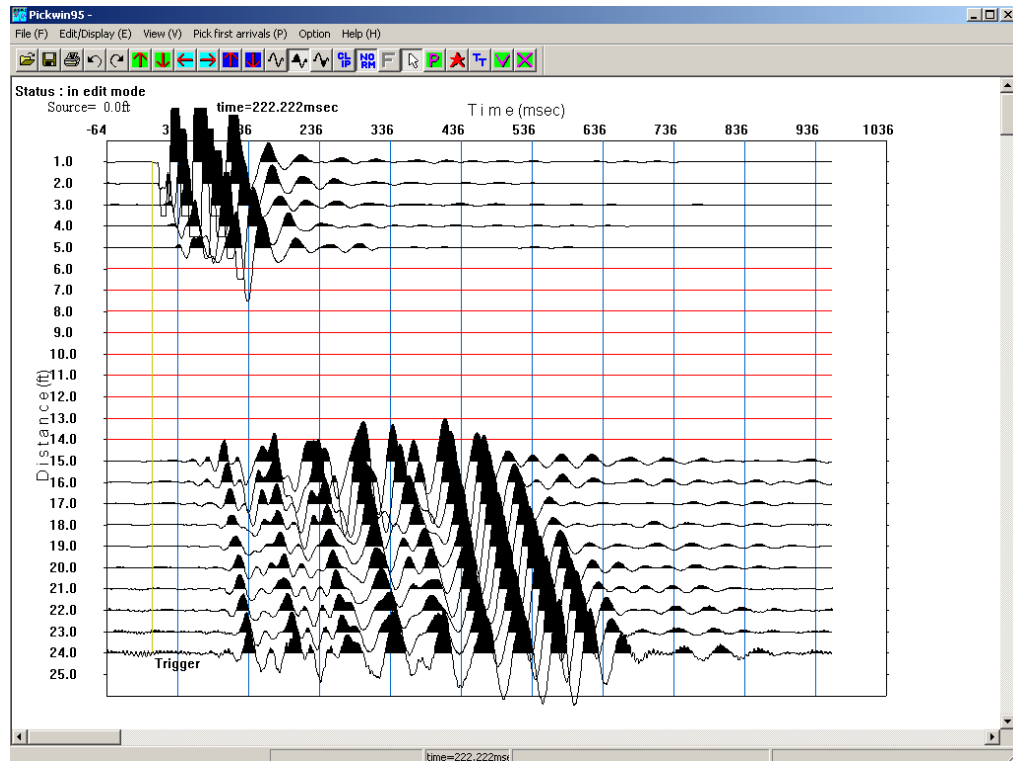

The selected trace(s) will now be “killed” (zeroed), as shown above.

3.2.5.3 Delete

To delete a selected trace(s), click on “Delete trace(s)” from the sub-menu:

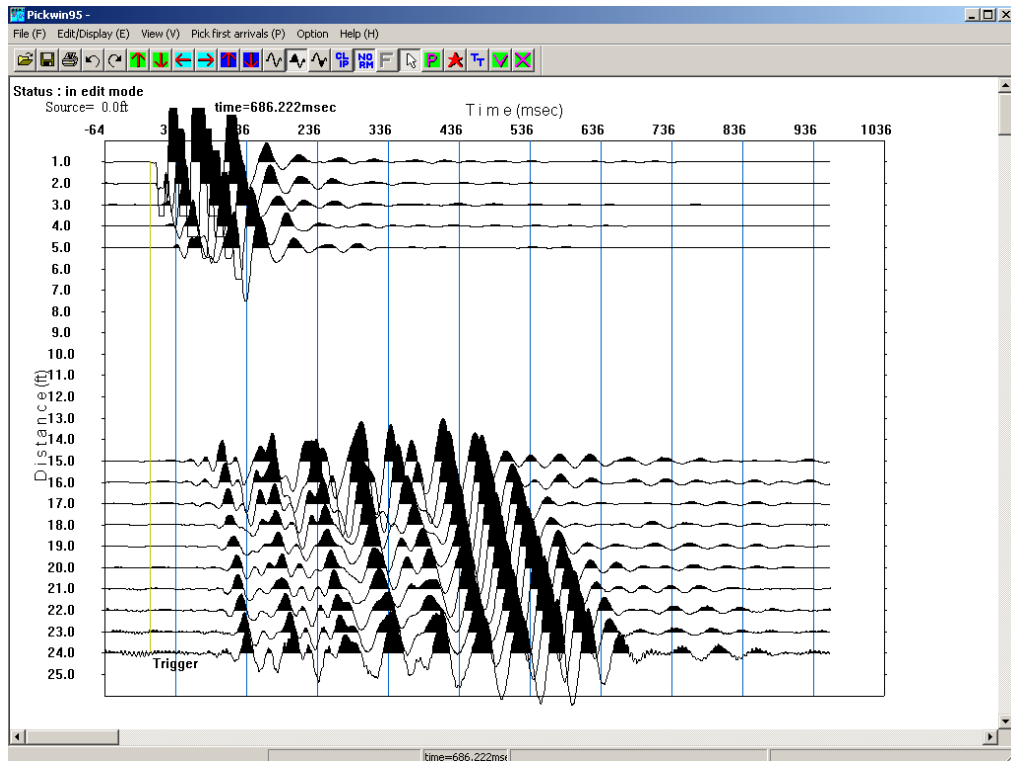

The selected trace(s) will now be deleted, as shown above.

3.2.6 Time Shift Traces

To shift the time axis of all of the traces, choose “Time shift traces”. You will see the following dialog box:

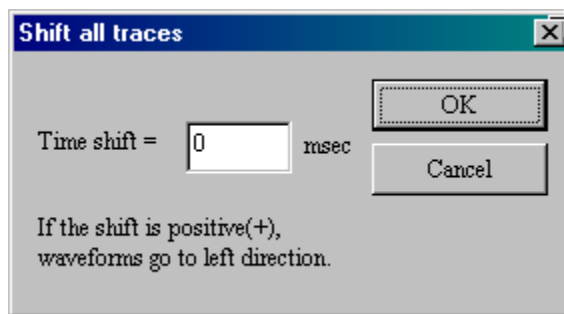

Choose an amount of time (in milliseconds) to shift the record and click OK. The record may be shifted in a positive or negative time direction. In the example shown below, a negative 100 msec shift has been applied.

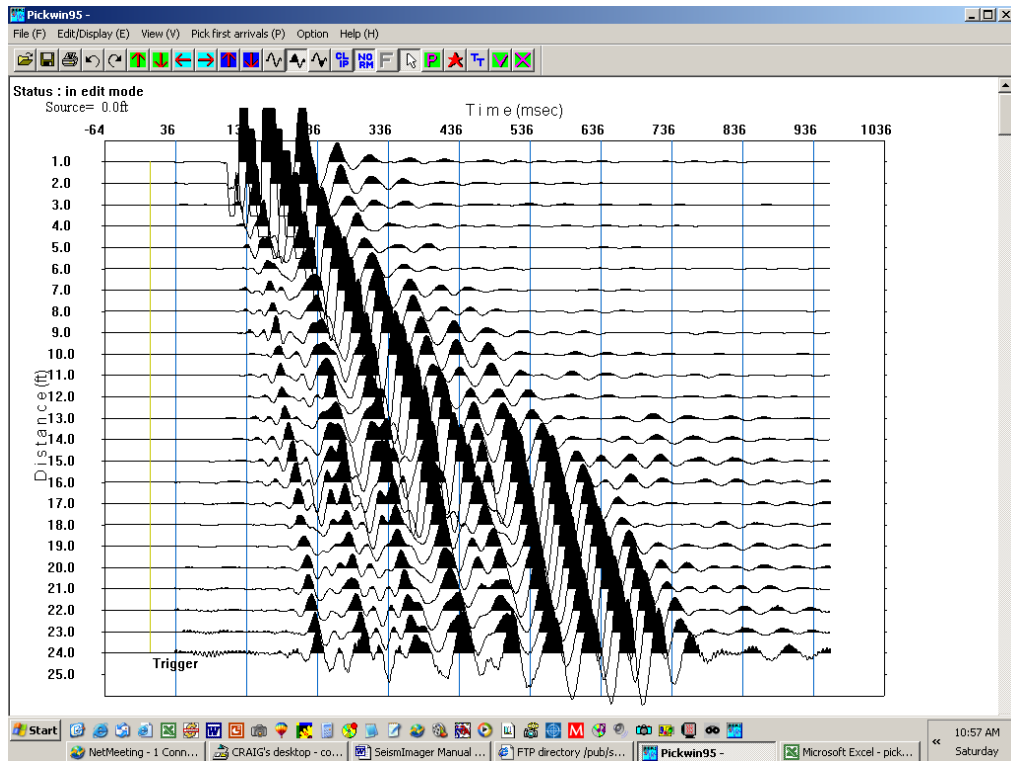

Note: A positive (+) value will shift the record to the left and shorten the record time of the traces. A negative (-) value will shift the record to the right or increase the record time of the traces.

3.2.7 Correct Shot Time

Depending on your triggering methodology, you may need to correct the time of the shot. This is often the case when you use a geophone to trigger the seismograph. In the example below, channel 25 has been connected to a geophone placed next to the source to record the actual source time (which, in this case, came about 80 msec after the seismograph triggered).

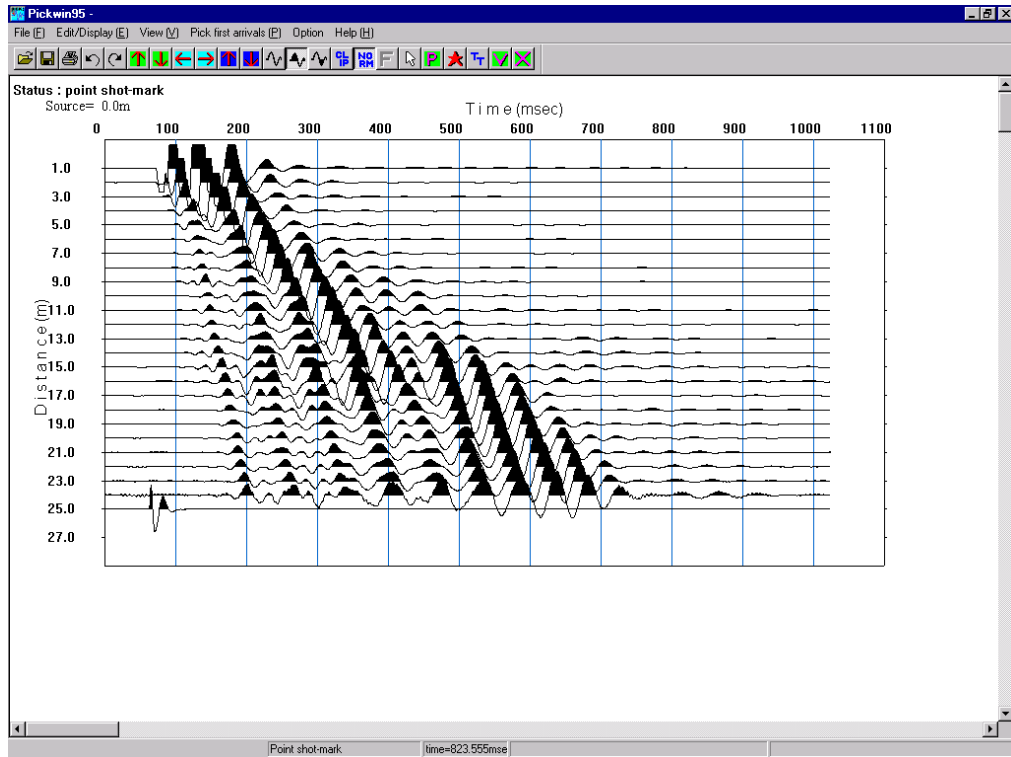

To correct the shot time, choose “Correct shot time” in the **Edit/Display** menu. (notice that “point-shot mark” is now displayed in the editing status mode in the upper left-hand corner). Position the cursor along the time record to where you would like to set the correct time of the shot and click. The time-position of the cursor is shown at the bottom of the window.

The traces will be adjusted for the corrected shot time, as shown below:

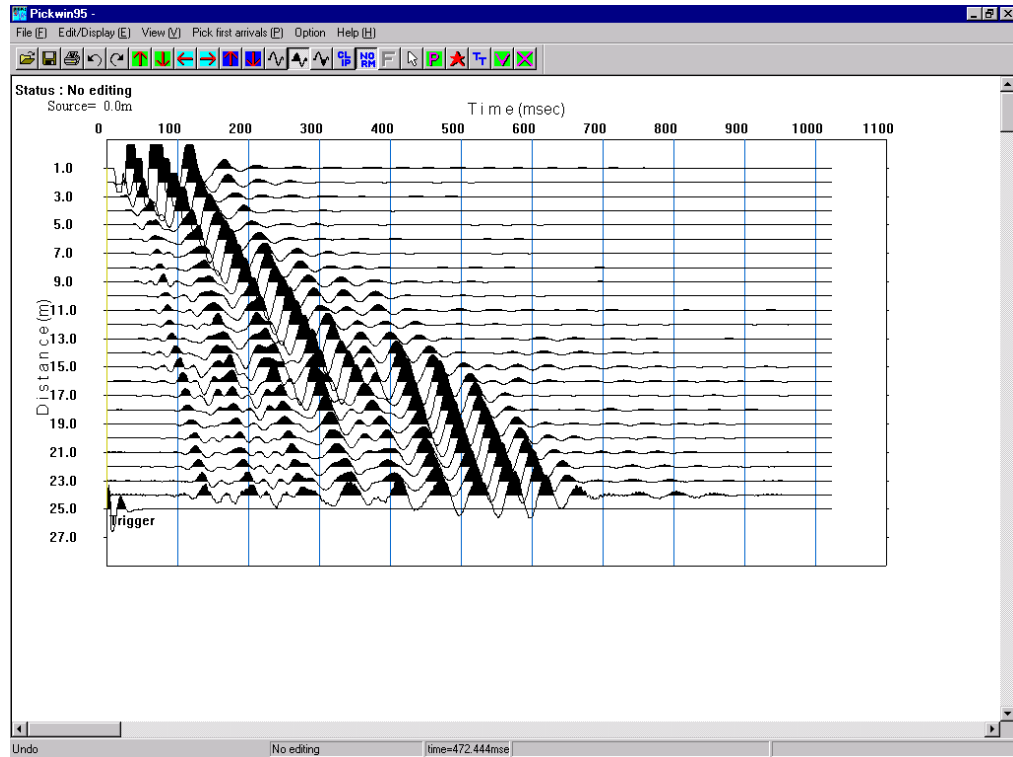

3.2.8 Automatic Shift

Some styles of surveying require the ability to append shot records together. For instance, if the goals of your survey require more channels than are available, you may overcome this by laying out several individual spreads end-to-end, and re-occupying some or all of the shot points. As an example, suppose you wish to do a 48-channel, 5-shot spread, but you only have a 24-channel seismograph available. You may simulate this through the following procedure:

- lay out the “left” half of the spread (all 24 of your channels),
- do your five shots *as if* the entire 48-channel spread is on the ground,
- pick up the 24-channels and moving them over to the “right” half of the spread,
- redo your 5 shots.

Once this has been completed, you have acquired the exact same data that you would have required had you laid out 48 channels all at once and simply done 5 shots.

When conducting more than one shot at the same location, the physical properties of the earth can be altered, leading to slight differences in local velocities. This, in turn, can lead to a slight difference in traveltimes to equivalent geophone stations between the first and subsequent shots. This is especially true when using explosives. To account and correct for this, it is best to overlap one or two geophones when acquiring data in this fashion. The *Automatic shift* in SeisImager/2D can then be used to correct for any change in traveltimes from one occupation to the next. This is demonstrated in the following example.

Read in the first half of the spread. Next, read in the second half. You will be asked if it is new data, or if you would like to append it to the present data:

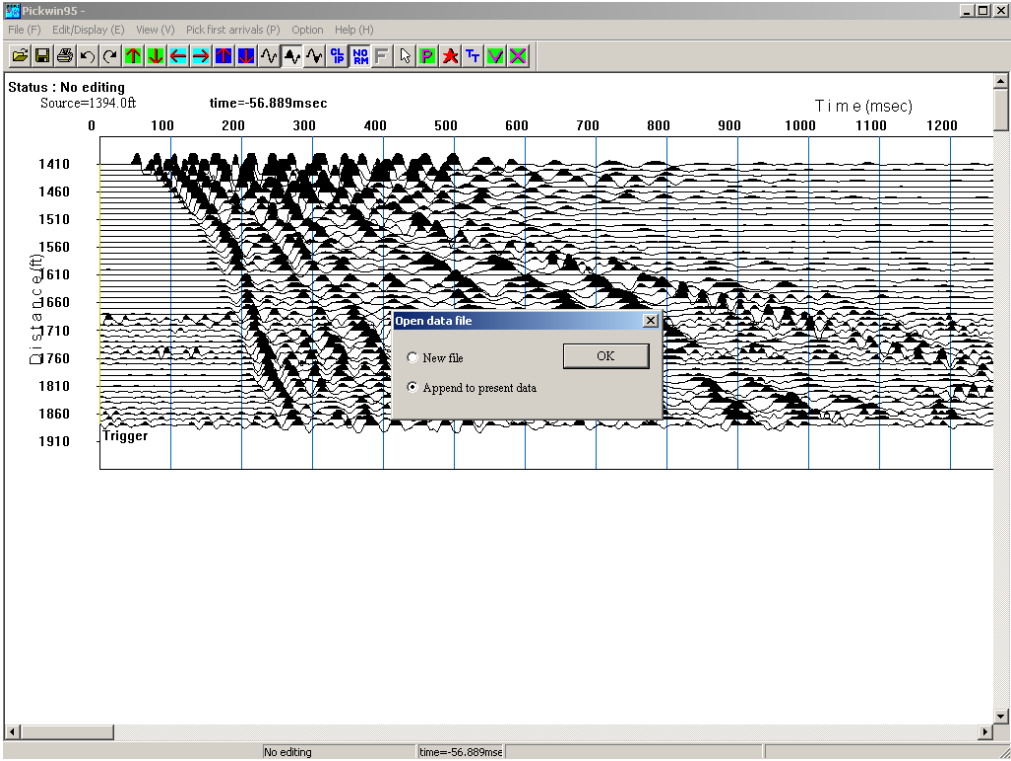

Choose "Append to present data". Next, you will be presented with the following dialog box:

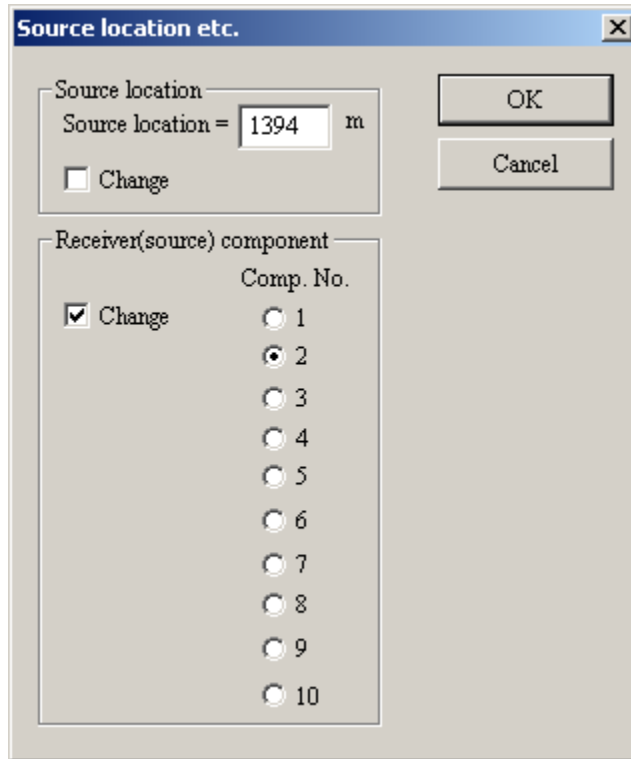

If you need to correct the source location (read from the SEG-2 file header), you may do so here. The “component number” is used to keep different spreads separate, and will automatically increment each time you append a new file. In this case, the component number defaulted to “2”. You may append up to 10 files.

***Note:** The “Change” check box must be checked for any changes you make in the above menu to actually take effect.*

Press **OK** and the next file will be appended to the first:

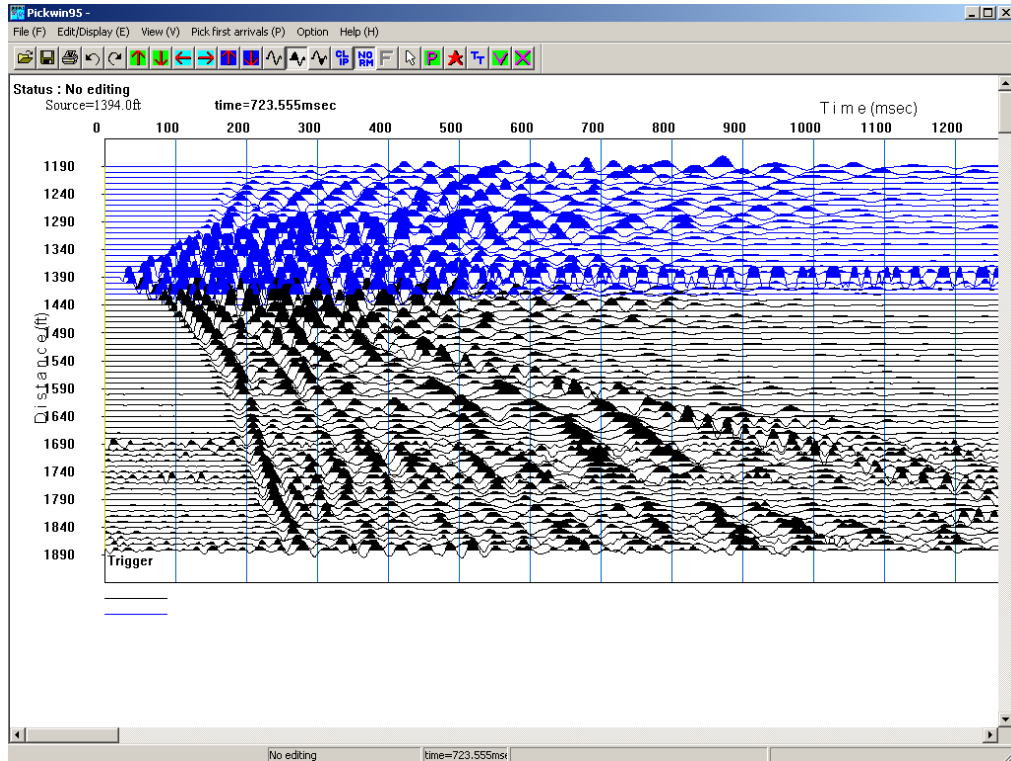

If we zoom in, we can see that stations 1410 and 1420 overlap:

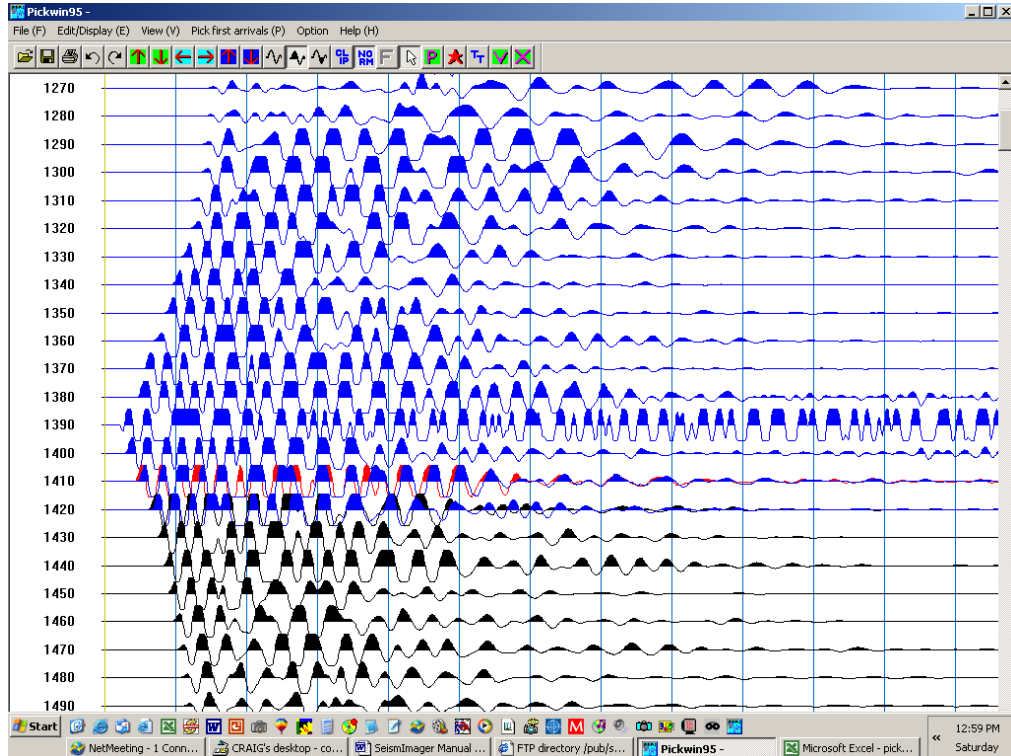

Note that there is a slight time shift between the two. To eliminate this, select one of the overlapping traces (the red trace shown above), and then select “Automatic shift”:

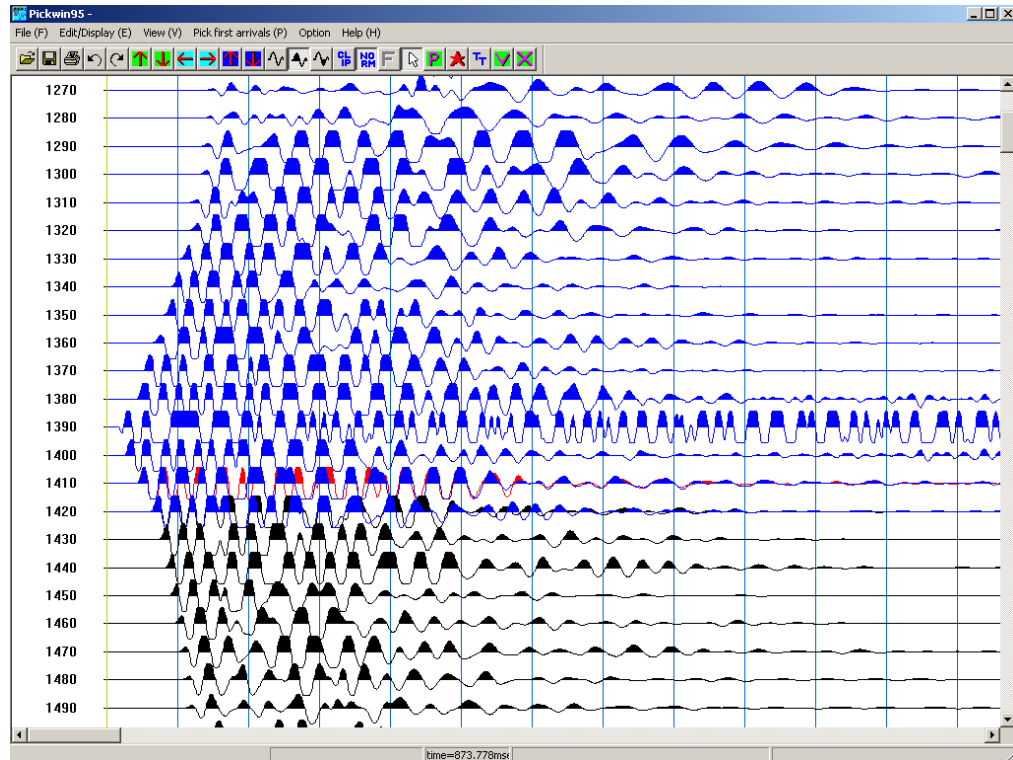

The second spread has been shifted in time to correspond with the first.

3.2.9 Correct S-wave

When doing a shear or “S-wave” survey, it is common practice to do reverse-polarity shots in order to facilitate the identification of shear wave arrivals. It is useful to overlay reverse-polarity shots from the same shot point. This can be done by reading in the first shot, and then appending the second, resulting in an overlay like the one shown below:

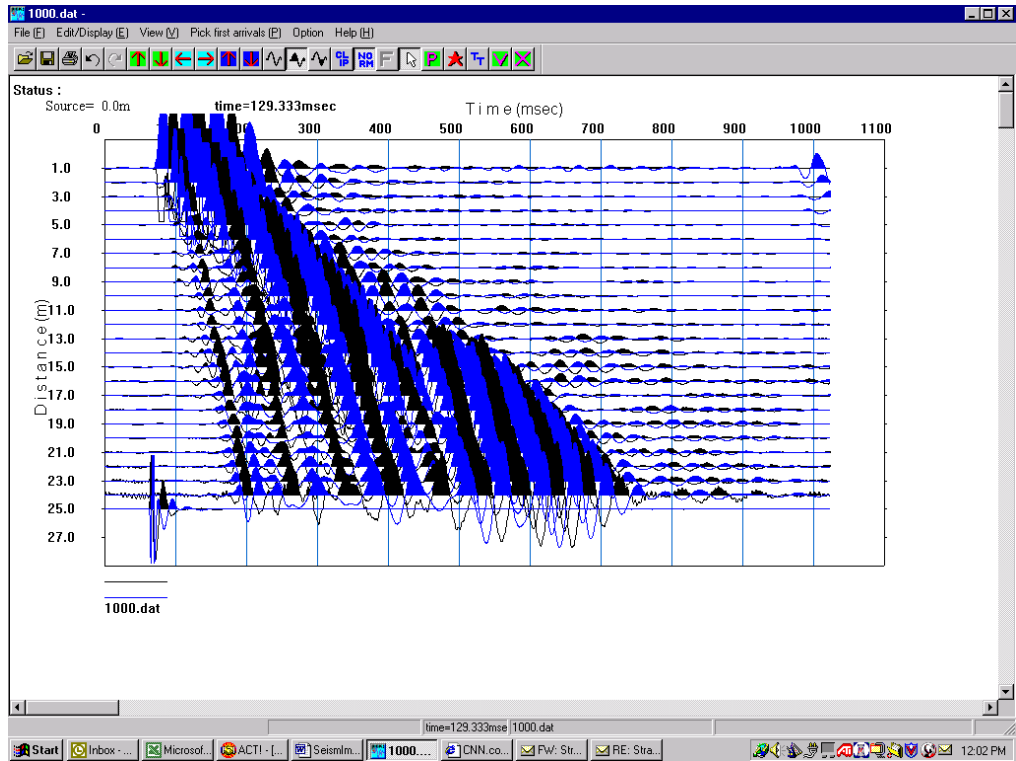

Ideally, the first shear wave arrival times will be identical for both records. However, it is often the case that they are not – one is often shifted slightly in time. This is quite common when the shear wave source consists of a long plank of wood or other non-point source.

To correct the S-waves to coincide at the same arrival times, click on “Correct S-wave” in the **Edit/Display** menu:

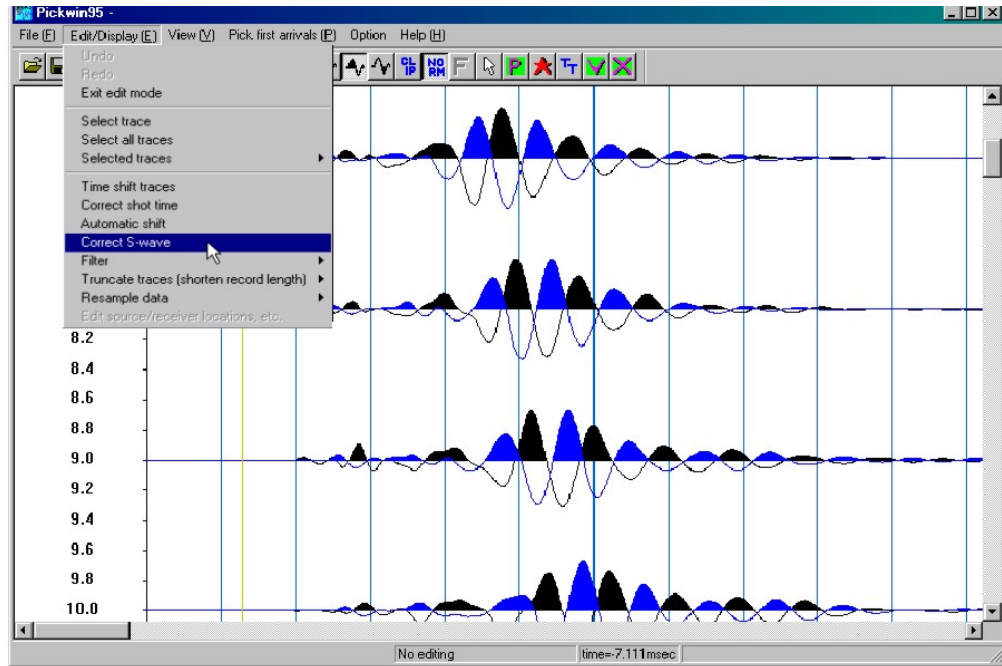

A cross-correlation of the oppositely-polarized traces will be done in an attempt to better align first breaks. An example of the effect is shown below:

Before correction

After correction

3.2.10 Filter

Filters can be used to remove noise caused by wind, traffic, and other sources. You may apply high-cut filters and low cut filters. To apply a 1000 Hz high-cut filter, press **CTRL-H**. Each subsequent press of **CTRL-H** will multiply the corner frequency by 0.8, so that the second press applies an 800 Hz filter, the third press applies a 640 Hz filter, and so on.

To set a 5 Hz low cut filter, press **CTRL-L**. In a similar fashion to that described above, each subsequent press increases the corner frequency by 1.5.

Below is an unfiltered record with some high-frequency noise in the early part of the record:

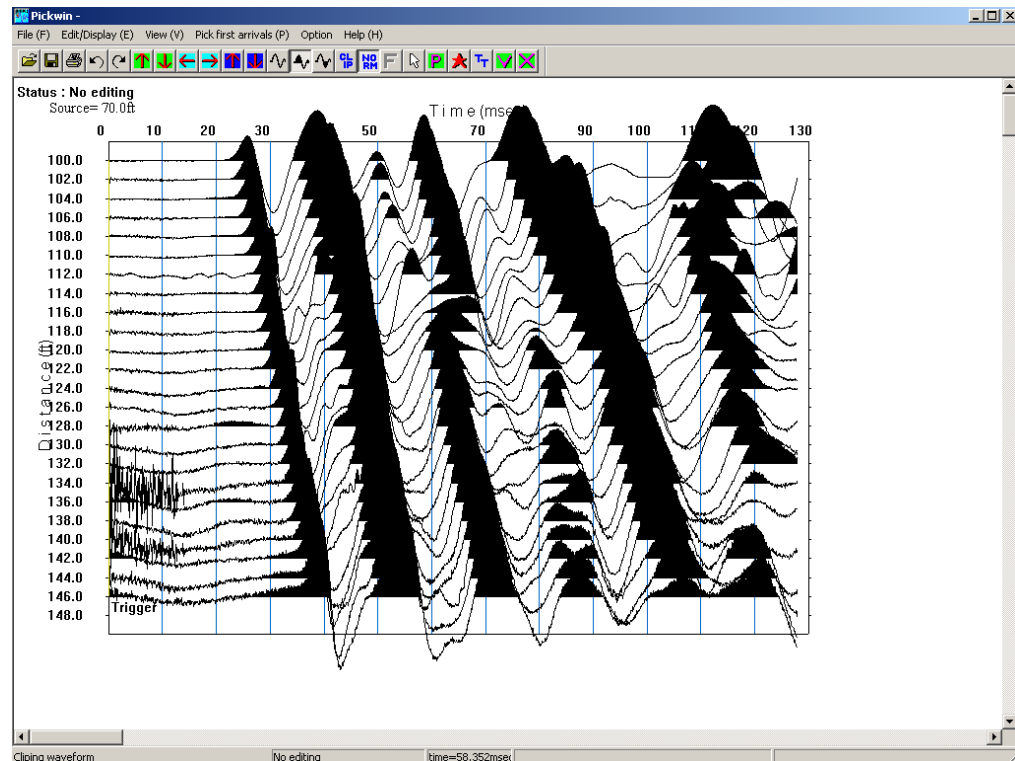

Here is the same record after applying a 512 Hz high-cut filter (four presses of **CTRL-H**):

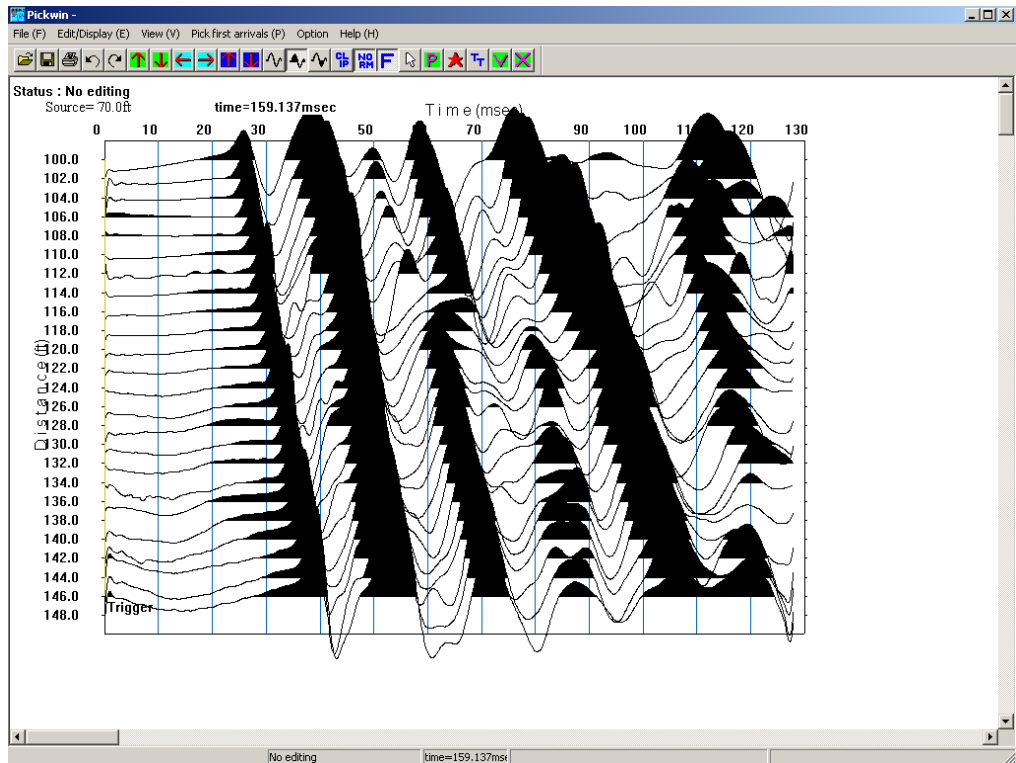

Below is a record with some low-frequency noise in the far channels:

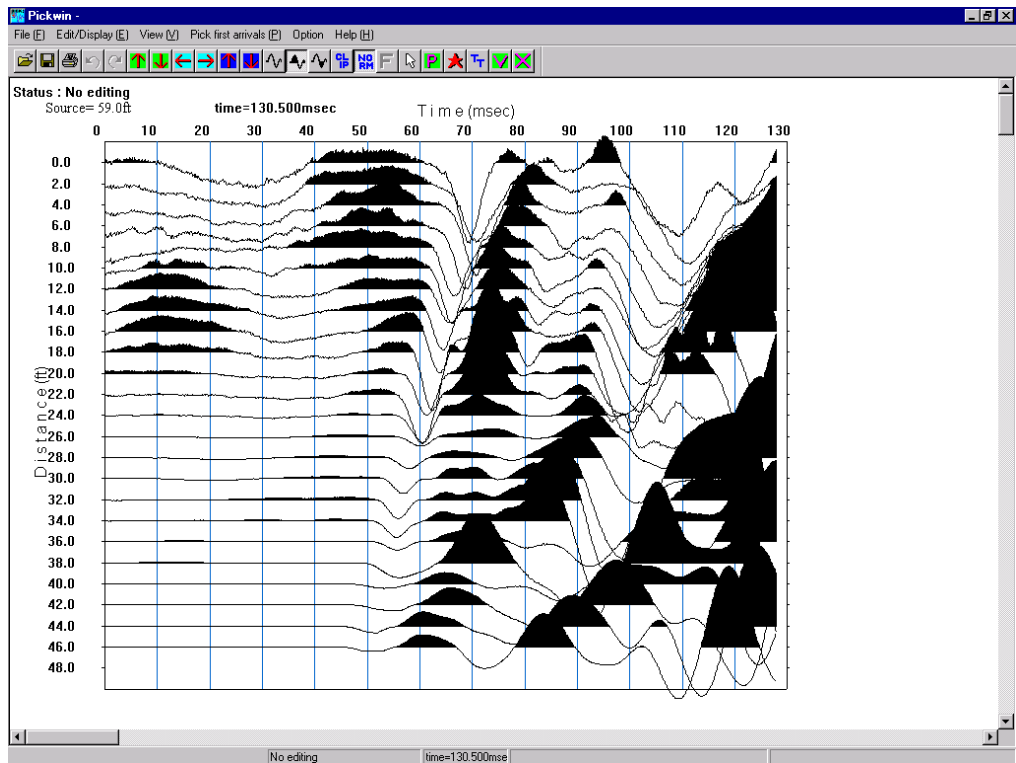

Here is the same record after applying a 38 Hz low-cut filter (six presses of CTRL-L):

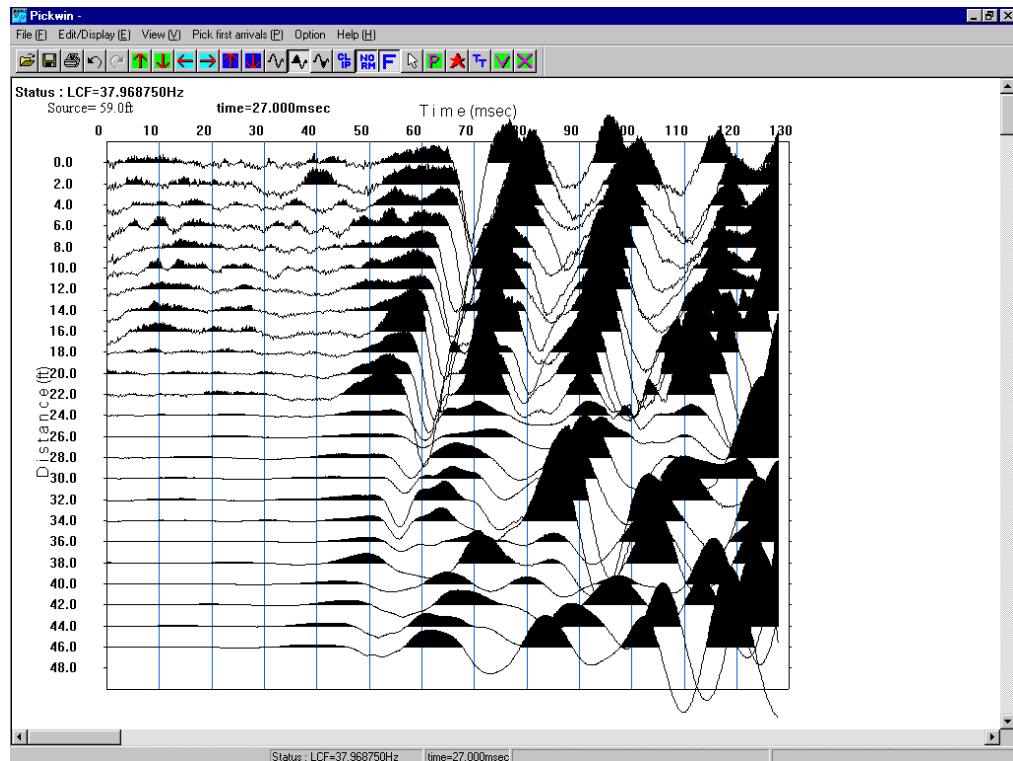

To disable all filters and return to the raw data, press the  tool button.

3.2.11 Truncate Traces (Shorten Record Length)

To shorten or truncate the record length, click on “Truncate traces (shorten record length)”. A sub-menu with the Pickwin default options for truncating traces will be displayed.

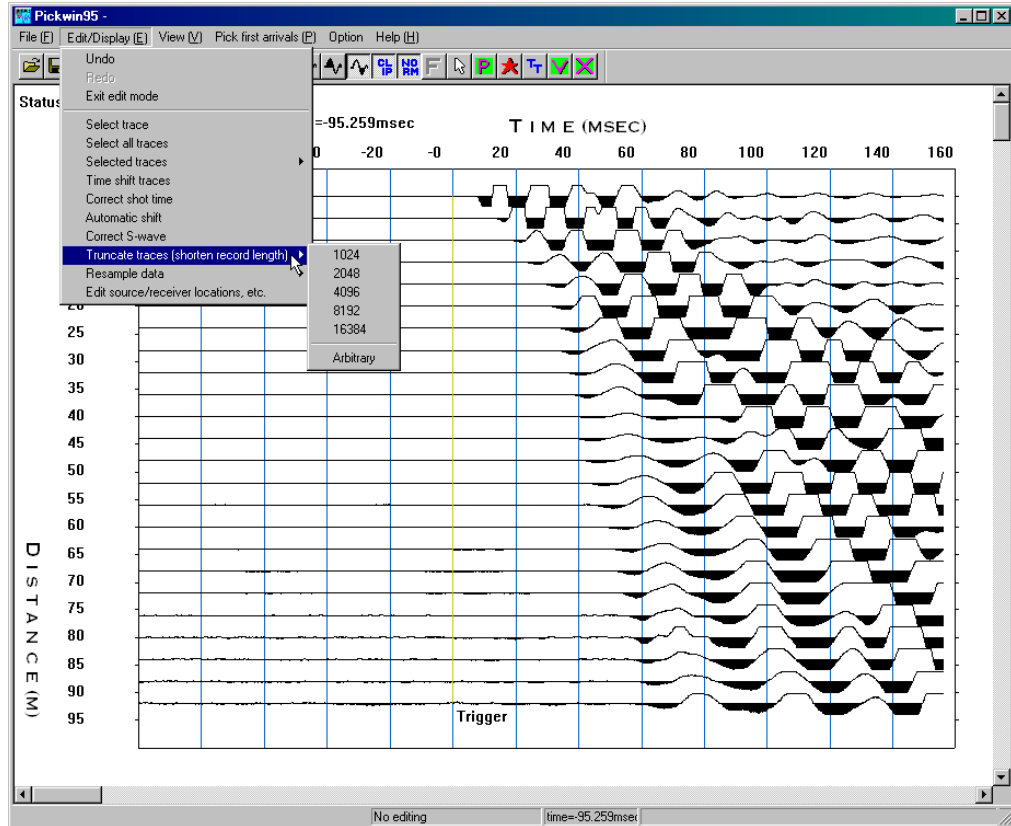

Click on a default truncation of 1024, 2048, 4096, 8192, or 16384 samples to truncate the traces to the respective record length. Clicking on “Arbitrary” can specify an arbitrary truncation of a trace. If an arbitrary truncation of a trace is chosen, the following dialog box will be displayed:

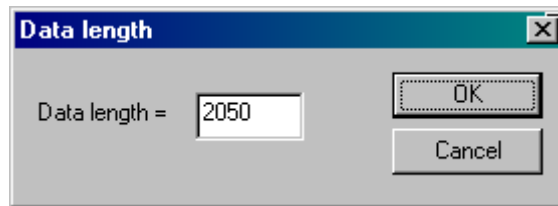

Type the desired data length or number of samples for the traces. Click **OK** and the traces will be truncated or shortened accordingly.

3.2.12 Resample Data

To resample data, click on “Resample data”. From the sub-menu, click on one of the default re-sampling options: “Every other”, “Every 4th”, or “Every 8th”. This can be useful if the data has been over sampled and you wish to make the data files smaller.

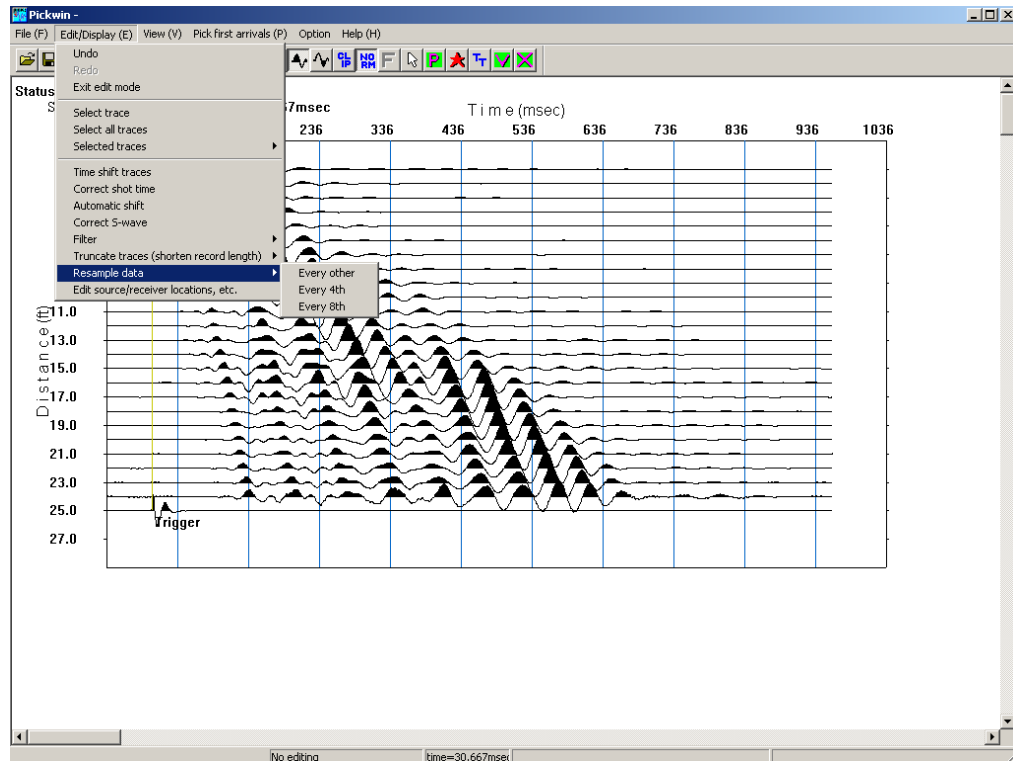

3.2.13 Edit Source/Receiver Locations, Etc.

To edit source and receiver locations of the file to reflect that of the actual survey, click on “Edit source/receiver locations, etc.”. The following dialog box, with appropriate parameters respective to your survey, will be displayed:

Edit the geometry of the survey by clicking in a box and typing in the new value. If you change the “Group interval” or “First geophone coordinate”, you must press the **Set** button to affect the change. Only six geophones are displayed at a time. Use the **Back** and **Next** buttons to scroll through the geophones. Click **OK** when changes are complete.

3.3 View Menu

Click on “View” to reveal the **View** menu:

Many of the features in this menu are toggle switches – clicking on them either enables (signified by a “[” next to the selection) or disables the feature. Most toggle switch items also have buttons on the tool bars, and all work the same way. In the discussion below, toggle switches are identified by a “[” and their tool bar button, if they have one.

3.3.1 Normalize Traces [

When traces are normalized, the maximum amplitude of each trace will be equalized. Lower amplitude traces (those farther from the source) will be “turned up” so that their maximum amplitude is equal to that of higher-amplitude traces. This has the effect of optimizing the appearance of the first breaks across the record, and is recommended when picking first breaks.

An example of normalized traces is shown below, followed by a record with normalization disabled.

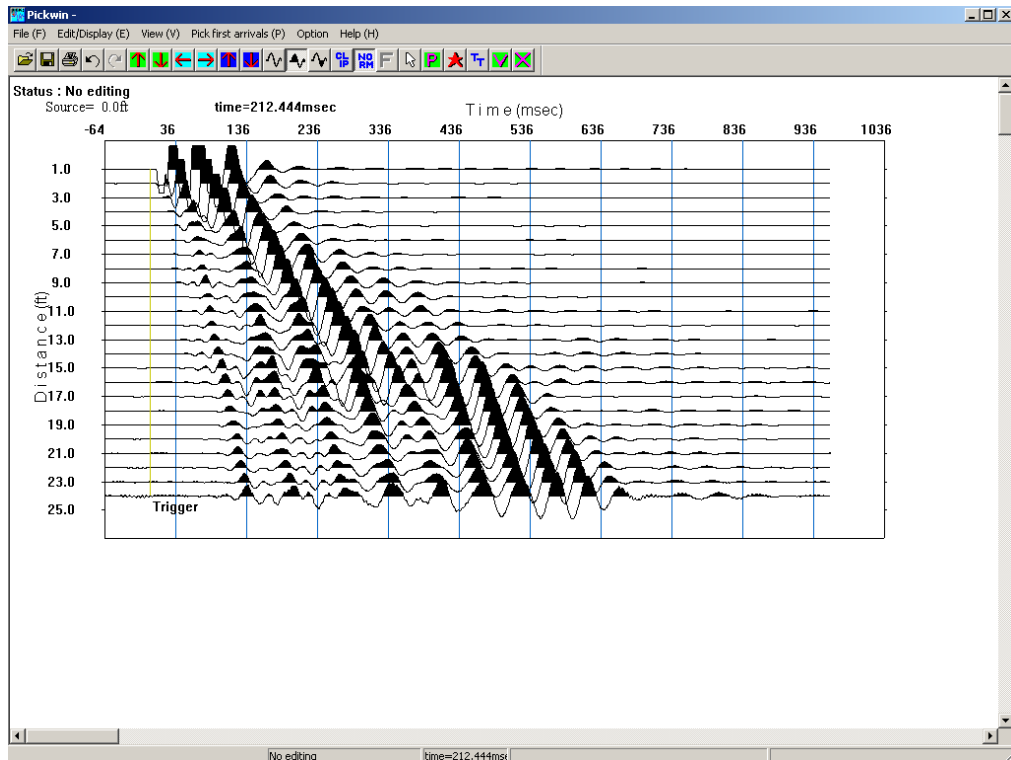

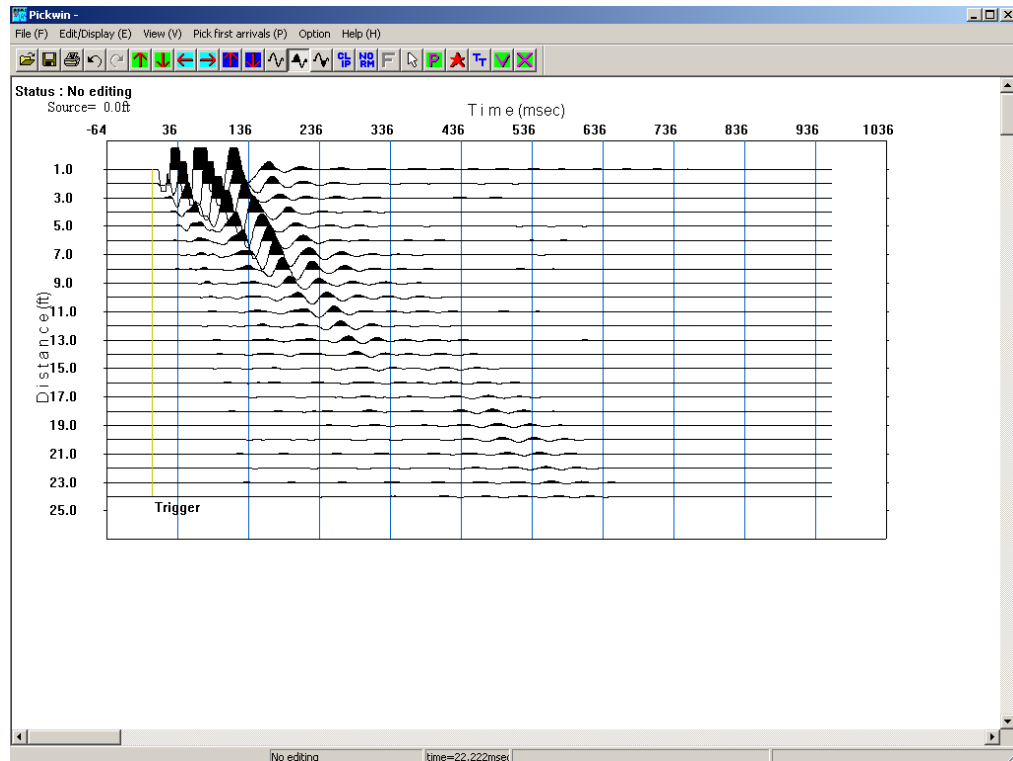

3.3.2 Clip Traces [

The “Clip traces” feature is useful in preventing adjacent traces from interfering with each other and obscuring the first breaks. An example of clipped traces is shown below.

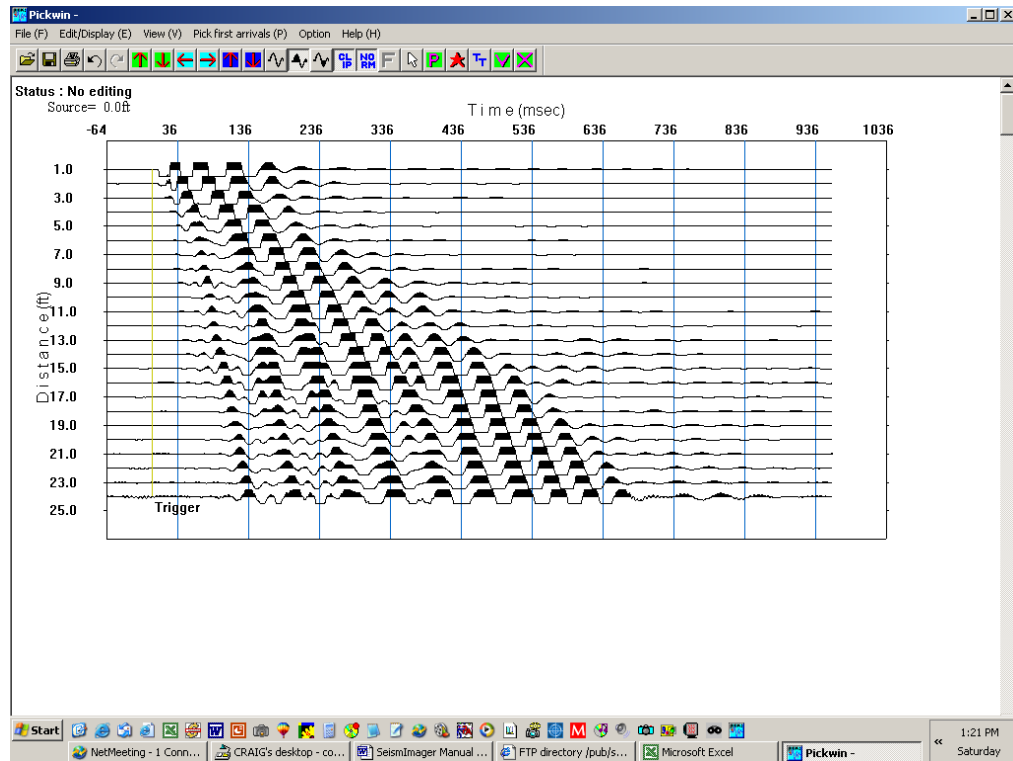

3.3.3 Trace Shading [

In addition to the positive-shaded trace display used in the previous examples, you may also shade negative amplitudes, or seismic traces may be displayed as simple wiggle traces. The trace style may be changed via the **Trace shading** sub-menu or with the appropriate tool buttons shown above.

An example of negative amplitude shading is shown below, followed by a wiggle-trace plot.

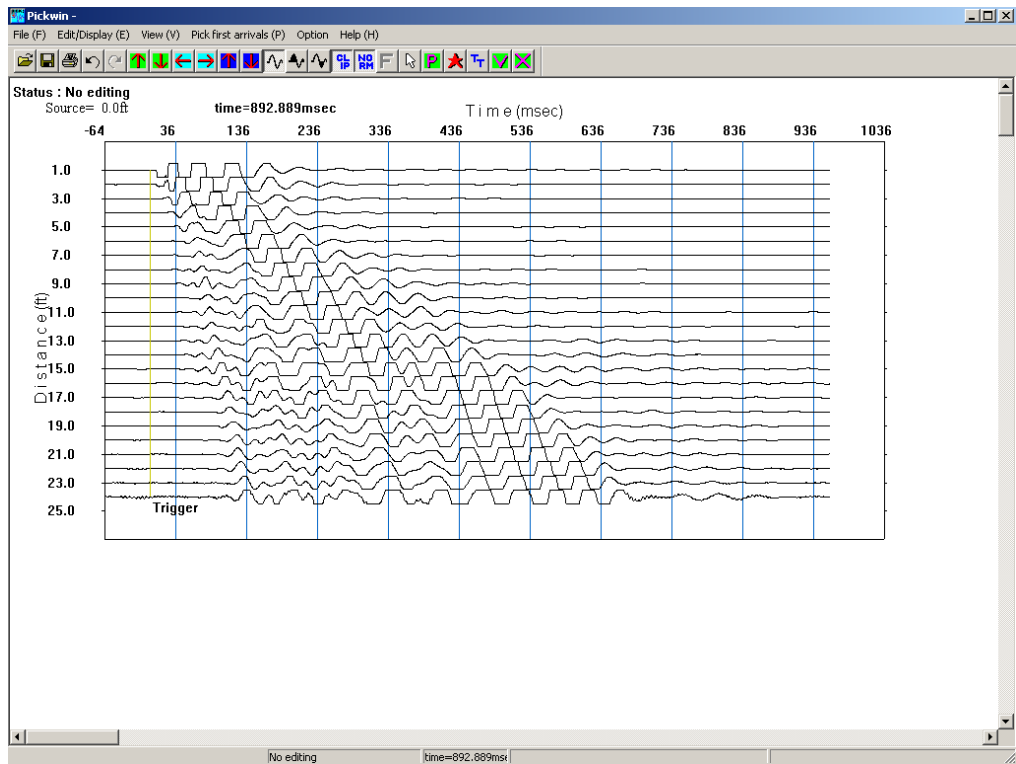
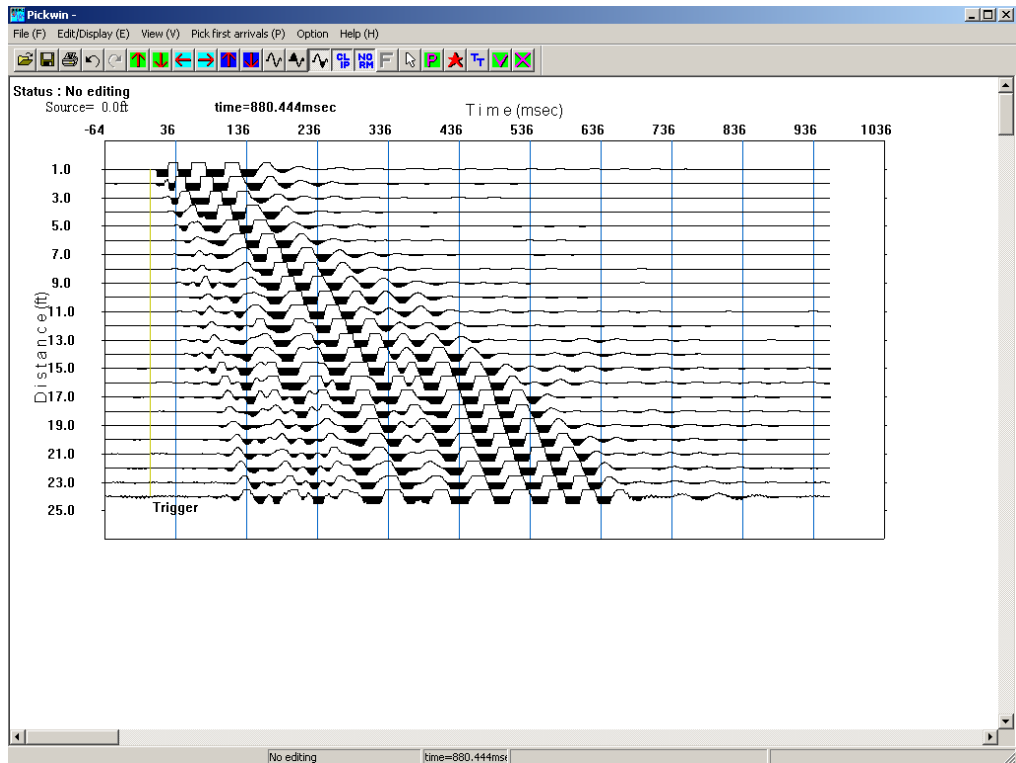

3.3.4 Number of Traces Shown

Note: Pickwin displays all of the seismic traces of a file by default.

To change the number of traces that are displayed, click on “Number of traces shown”. The following sub-menu will appear with the following choices of number of traces shown:

Select the number of traces you wish to display. Note that whatever is chosen, trace number 1 will be the first trace displayed. For instance, if you choose “12”, traces 1-12 will be displayed.

If “Arbitrary” is selected, the following dialog box will appear:

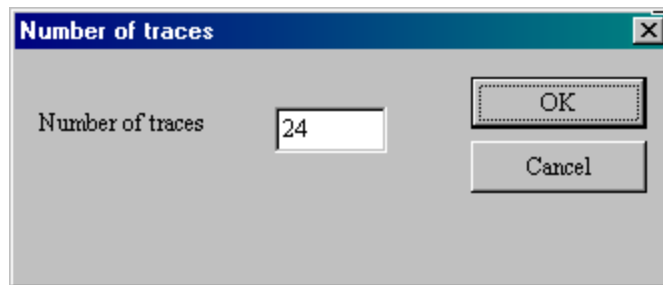

Enter the number of traces to display and press **OK**.

3.3.5 Show Traveltime Curves [

When picking first breaks, it is often helpful to display the first break picks of prior records in the survey as a reference. An example of this is shown below. The red line indicates the first breaks of the current record, while the green lines represent the first breaks of several prior records from the same seismic line. Pressing the tool button toggles the green traveltime curves on and off.

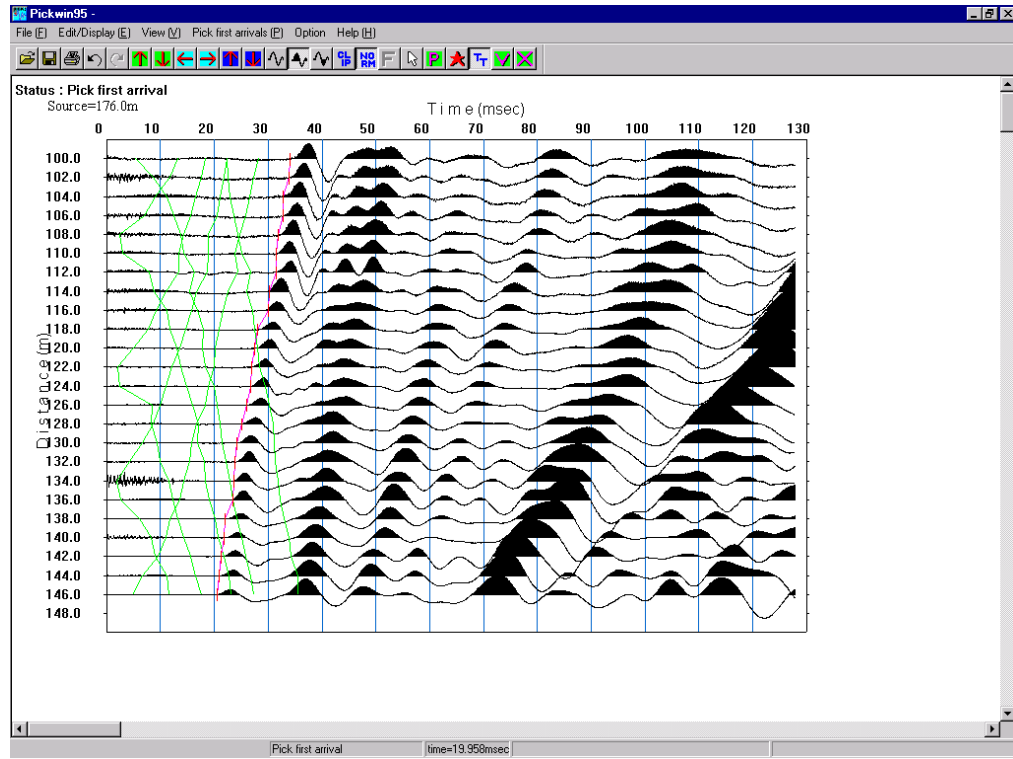

3.3.6 Axis Configuration

To change the display of the time (horizontal) axis or the distance (vertical) axis, click on “Axis configuration”. The following dialog box will appear:

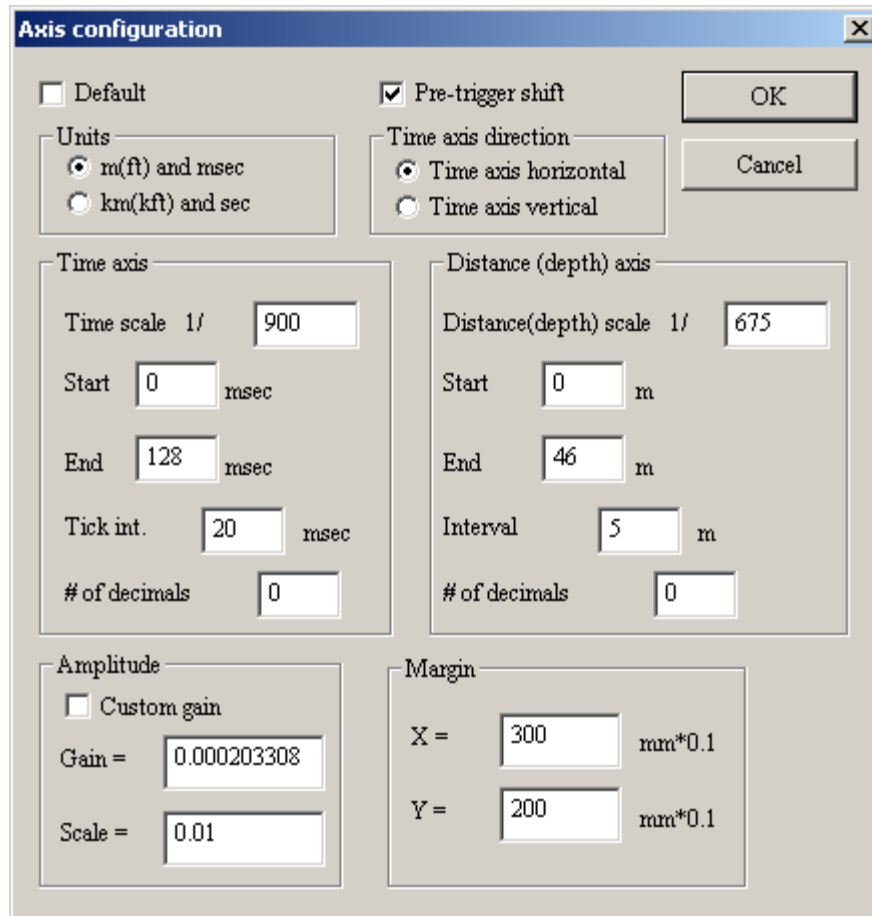

The functions of most of the parameters in the above dialog box are self-evident or can be deduced by simple trial and error. Configure the axes to your liking and click **OK** when finished .

3.3.7 Pre-trigger Shift [

If you have recorded pre-trigger data (accomplished by setting a “negative delay” on the seismograph), you may choose whether or not to display it. In the example below, the pre-trigger data is displayed, and the shot or zero time is indicated by the vertical tan line.

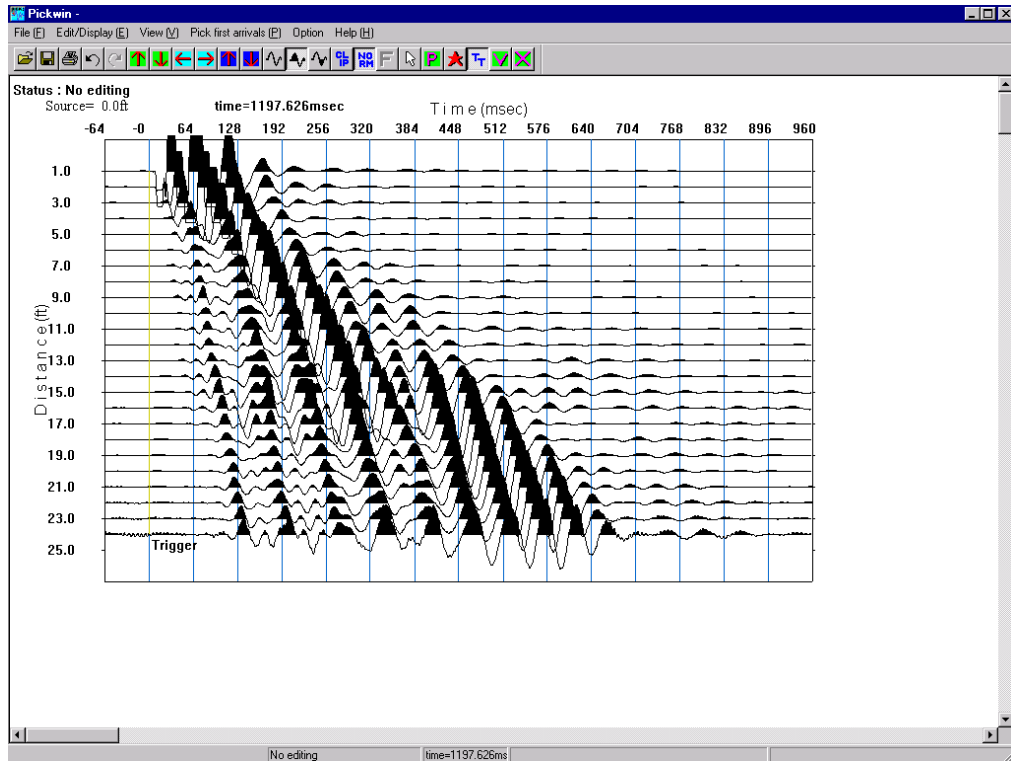

The pre-trigger shift setting can also be controlled from the “Axis Configuration” dialog box.

3.4 **Pick First Arrivals Menu**

Click on “Pick first arrivals” to reveal the **Pick First Arrivals** menu.

3.4.1 **Pick First Breaks**

To have the Pickwin module pick the first breaks, click on “Pick first breaks”, or click on the  button on the tool bar.

The first break picks chosen by Pickwin will appear as vertical red lines, as shown below:

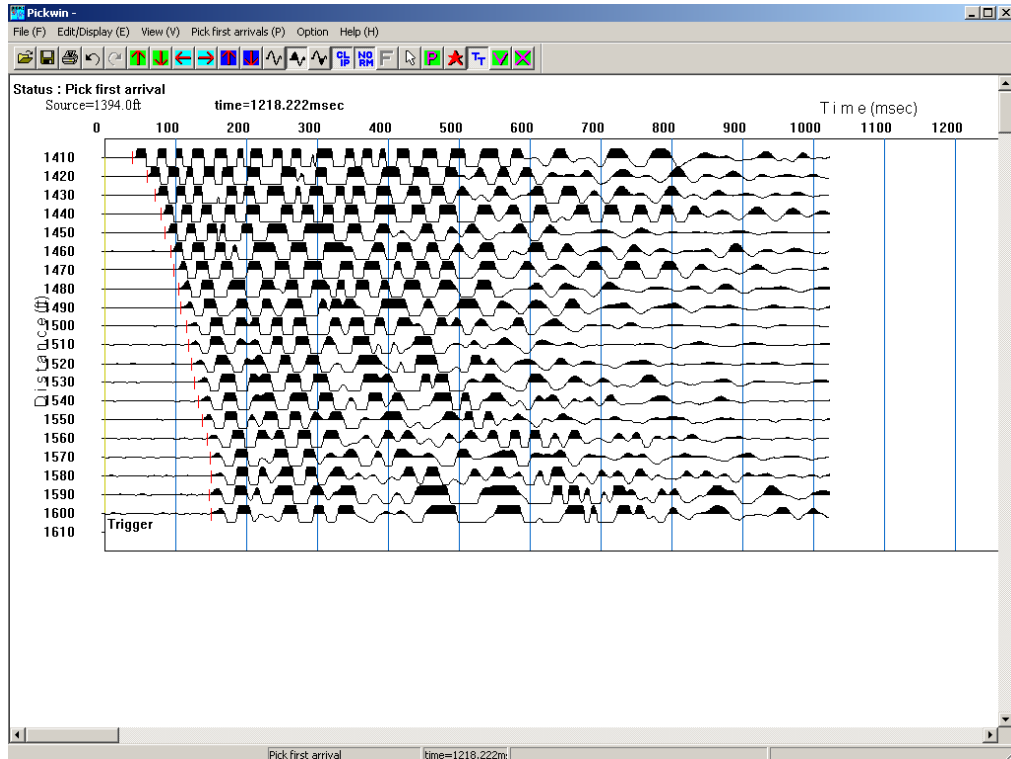

Once Pickwin has automatically picked the first arrivals, these picks may be manually adjusted. Simply position the mouse at the desired location and click. The first break pick will be updated. Repeat until you are satisfied that the first breaks have been assigned correctly to all traces.



Audio/video clip of First Break Picking Procedure

3.4.2 Linear Velocity Line

To measure the apparent velocity of a series of first break picks, click on “Linear velocity line”, or press the tool button.

Next, left click at the beginning of the series, and drag the cursor to the last break in the series. To fix the line, right click. The line will be labeled with the apparent velocity, as shown below:

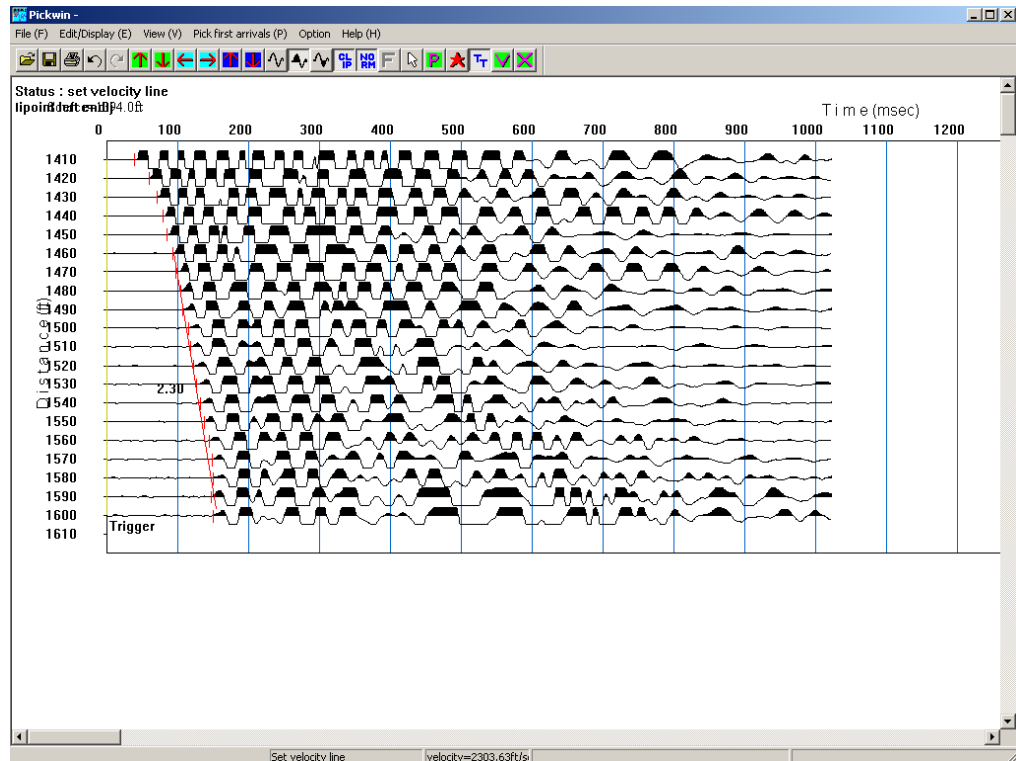

3.4.3 Delete All Velocity Lines

Choose “Delete all velocity lines” to remove any velocity lines from the display.

3.5 *Surface-Wave Analysis Menu*

Please refer to the separate manual on the software package SeisImager/SW for explanation of this menu.

3.6 *Option Menu*

Click on “Option” to reveal the **Option** menu.

3.6.1 Dimension Size

Click on “Dimension size” in the **Option** menu. A dialog box will appear with options to change the maximum samples and traces allowed to be displayed by the Pickwin module.

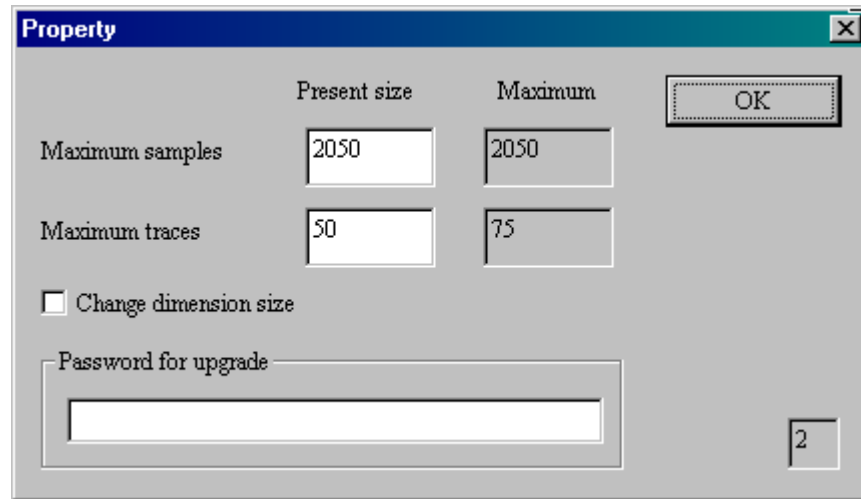

Note: A password is required to upgrade the maximum samples and traces displayed by Pickwin. Email (seismicsales@mail.geometrics.com), fax (408-954-0902), or call us (408-954-0522) to upgrade your software.

3.7 Help Menu

Click on “Help” to reveal the **Help** menu:

3.7.1 Version Info. (Pickwin) (A)

Click on “Version info.” to display the Pickwin Version number.

3.8 Additional Tool Buttons and Hot Keys

3.8.1 Increase Amplitude Tool Button and Hot Key ↑

The “Increase amplitude” tool button increases the amplitude of all of the traces. The up arrow key (↑) on the keyboard accomplishes the same thing.

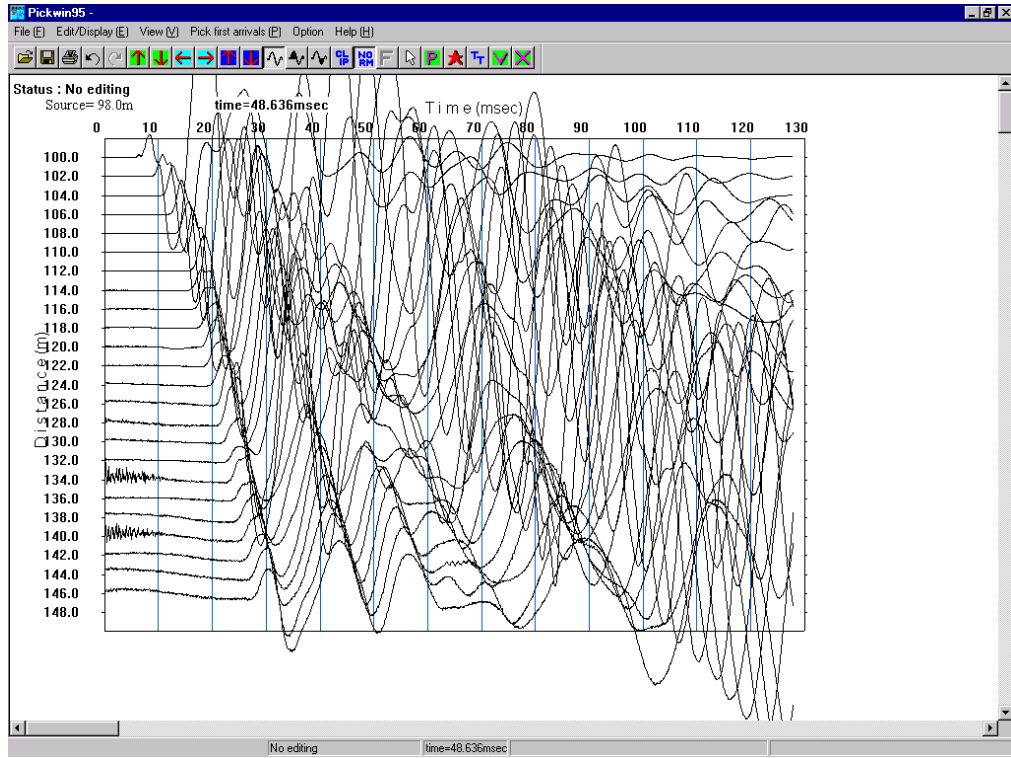

3.8.2 Decrease Amplitude Tool Button and Hot Key ↓

The “Decrease amplitude” tool button decreases the amplitudes of all of the traces. The down arrow key (↓) on the keyboard accomplishes the same thing.

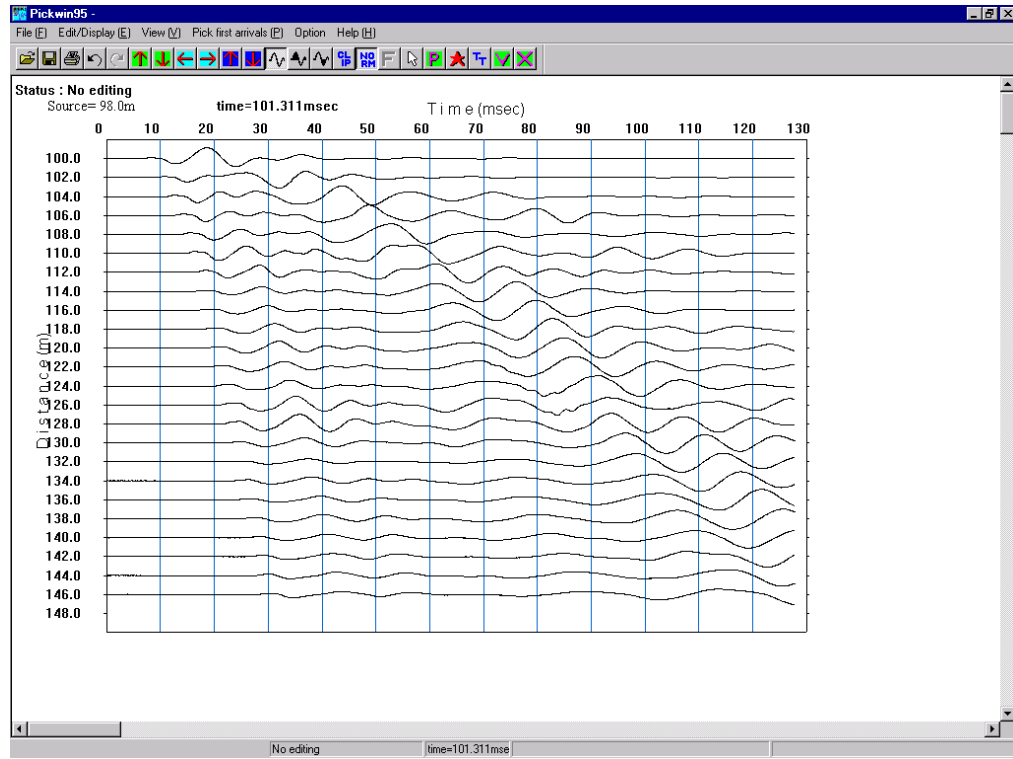

3.8.3 Increase Horizontal Axis Tool Button and Hot Key →

The “Increase horizontal axis” tool button increases the length of the horizontal (time) axis. The right arrow key (→) on the keyboard accomplishes the same thing.

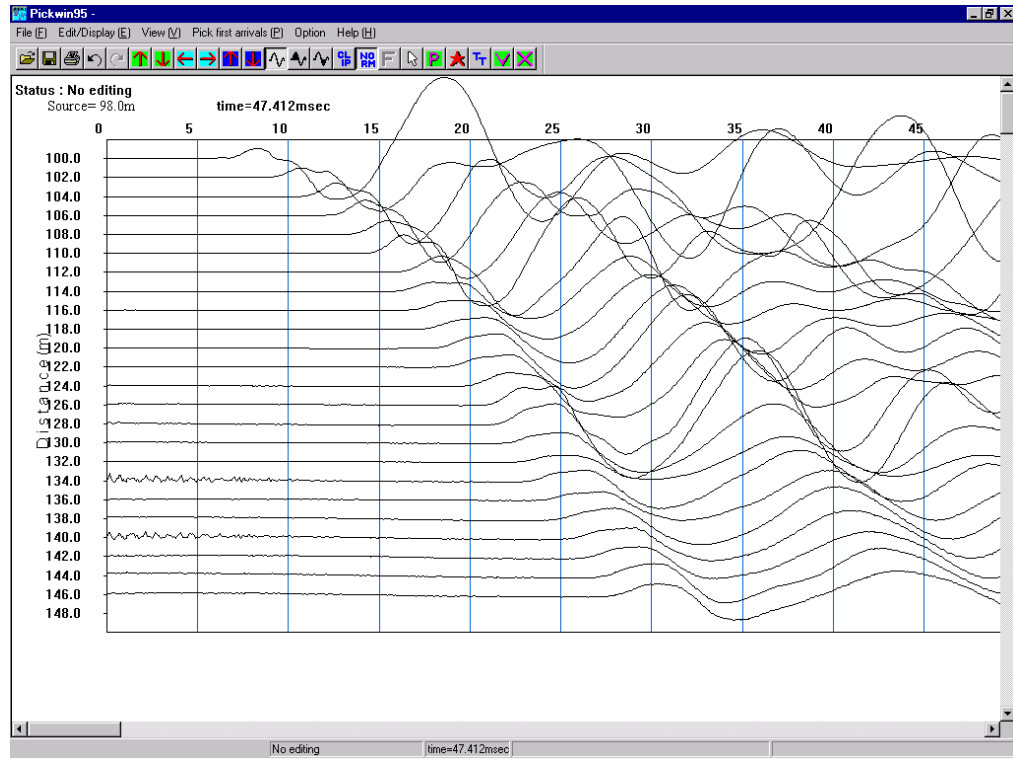

3.8.4 Decrease Horizontal Axis Tool Button and Hot Key ←

The “Decrease horizontal axis” tool button decreases the length of the horizontal (time) axis. The left arrow key (←) on the keyboard accomplishes the same thing.

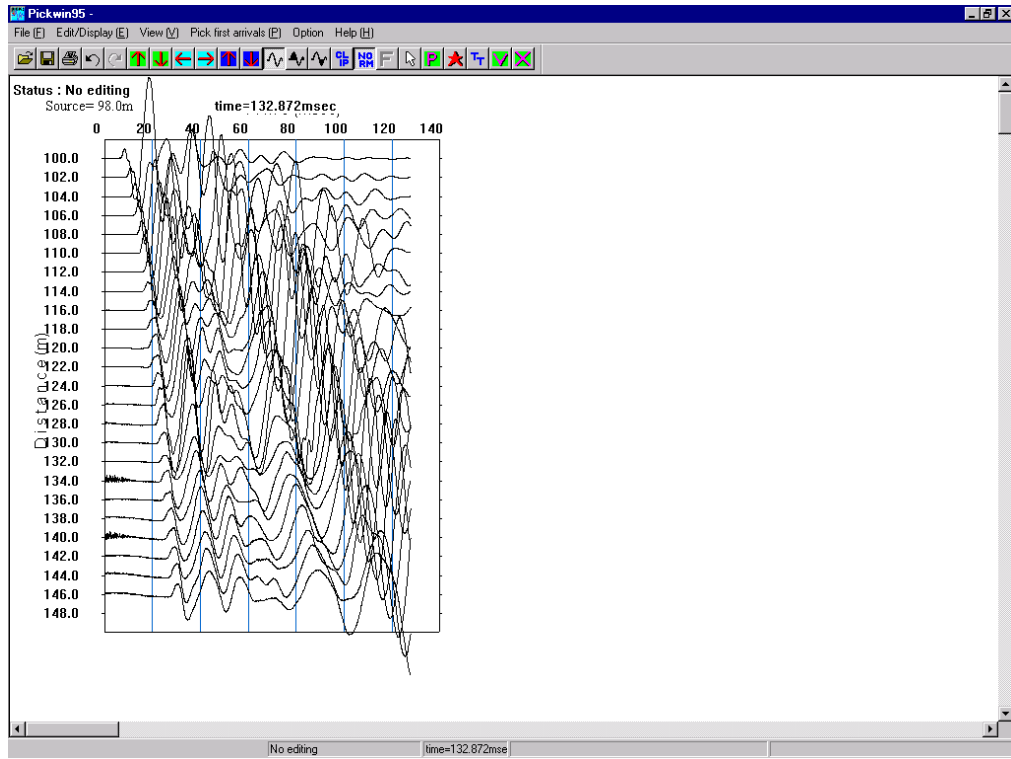

3.8.5 Increase Vertical Axis Tool Button and Hot Key SHIFT ↑

The “Increase vertical axis” tool button increases the length of the vertical (distance) axis. Pressing the up arrow key (↑) on the keyboard while holding down the SHIFT key accomplishes the same thing.

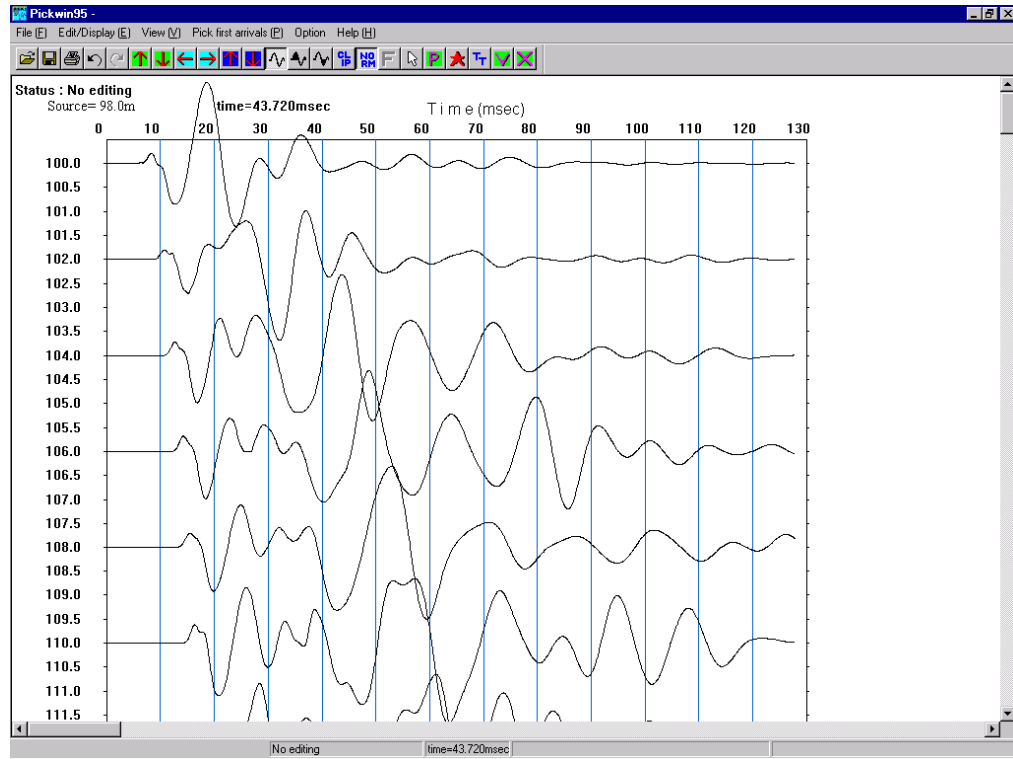

3.8.6 Decrease Vertical Axis Tool Button and Hot Key **SHIFT ↓**

The “Decrease vertical axis” tool button decreases the length of the vertical (distance) axis. Pressing the down arrow key (↓) on the keyboard while holding down the SHIFT key accomplishes the same thing.

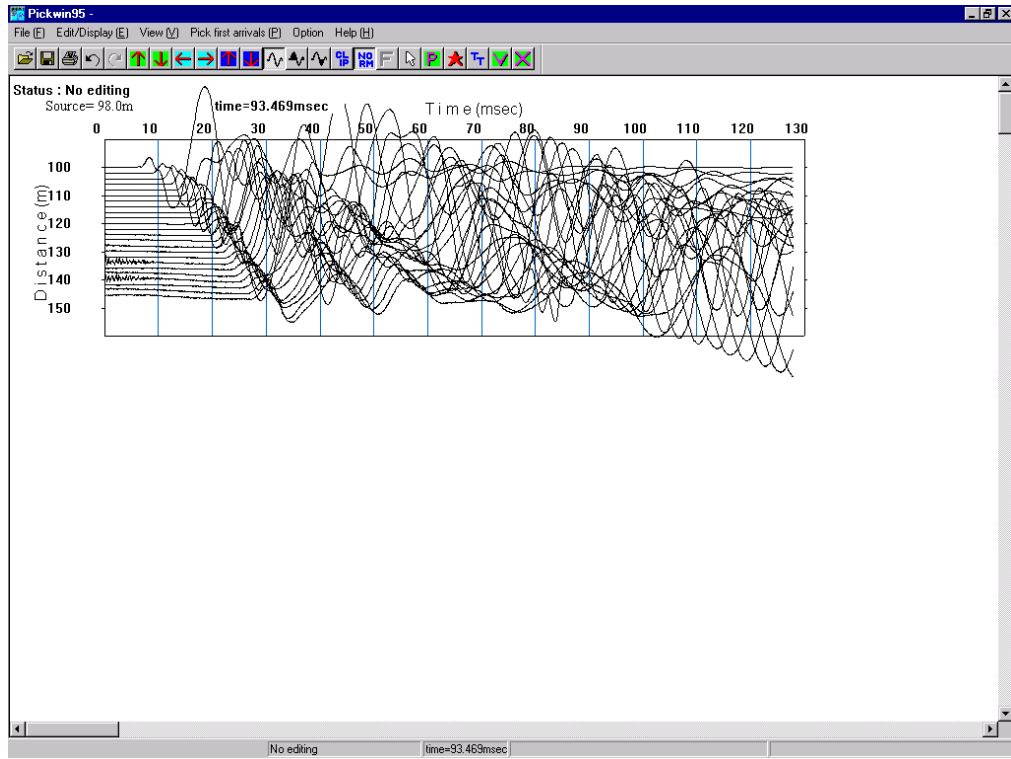

3.8.7 Draw Traveltime Curve Tool Button

Once first breaks have been picked for a file, press the  button. This will connect the first break picks with a red line. This is useful in making sure that there are no outliers that you may have missed.

Note: If a first break pick error is noticed after generating a traveltime curve, simply reposition the first break pick by clicking at the appropriate position.

Then, click on  button and the traveltime curve will be readjusted.

3.8.8 “X” Tool Button

This tool button exits from whatever “editing mode” you might be in. For instance, if you choose “Draw velocity line”, you are in an edit mode. In order to exit that edit mode (so you can, for instance, select traces), you must press the button.

3.8.9 Page Up Tool Button

If you have read in a group list of data files, you may page through from higher file number to lower file number by pressing the button.

3.8.10 Page Down Tool Button

If you have read in a group list of data files, you may page through from lower file number to higher file number by pressing the button.

4 The Plotrefa™ Module

Plotrefa is the interpretation module of SeisImager/2D. It takes the output of Pickwin as input, and through the application of one of the three available interpretation techniques, provides a velocity cross section. It includes many useful tools for facilitating data interpretation. We will step through the various menu items in a fashion similar to that above, and then apply each of the three interpretation techniques to the same data set.

Click on the  shortcut to start Plotrefa. You will see the following:

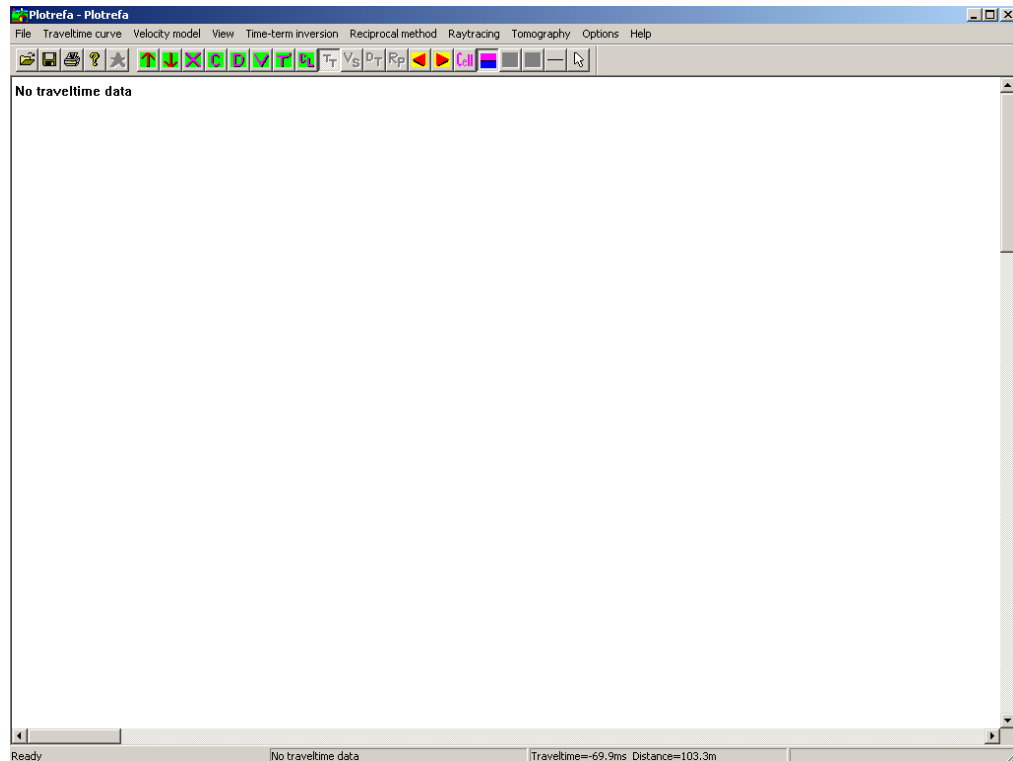

Like Pickwin, the user-interface of Plotrefa consists of a series of menus along with a toolbar. We will now discuss in detail the various menus of Plotrefa.

4.1 File Menu

Click on “File” to reveal the **File** menu:

4.1.1 Open Plotrefa File (Traveltime Data and Velocity Model)

To open a Plotrefa file, click on “Open Plotrefa file (traveltime data and velocity model)” or press the “Open file” tool button to read in a record. You will see the following dialog box:

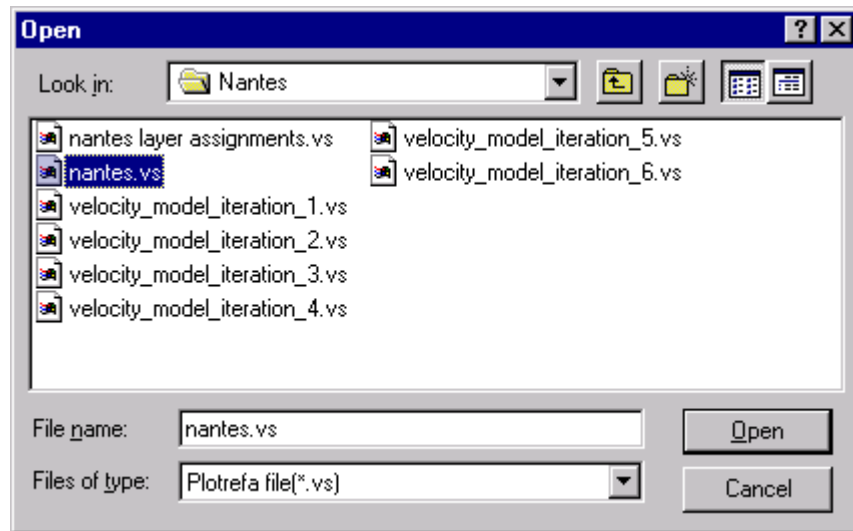

Find the folder your data resides in and open it. Plotrefa files from Pickwin have a “.vs” extension, so this is the default, and only “.vs” files will be displayed. Choose the file you want to read in by double clicking on it. You will see a travelttime plot like the one below:

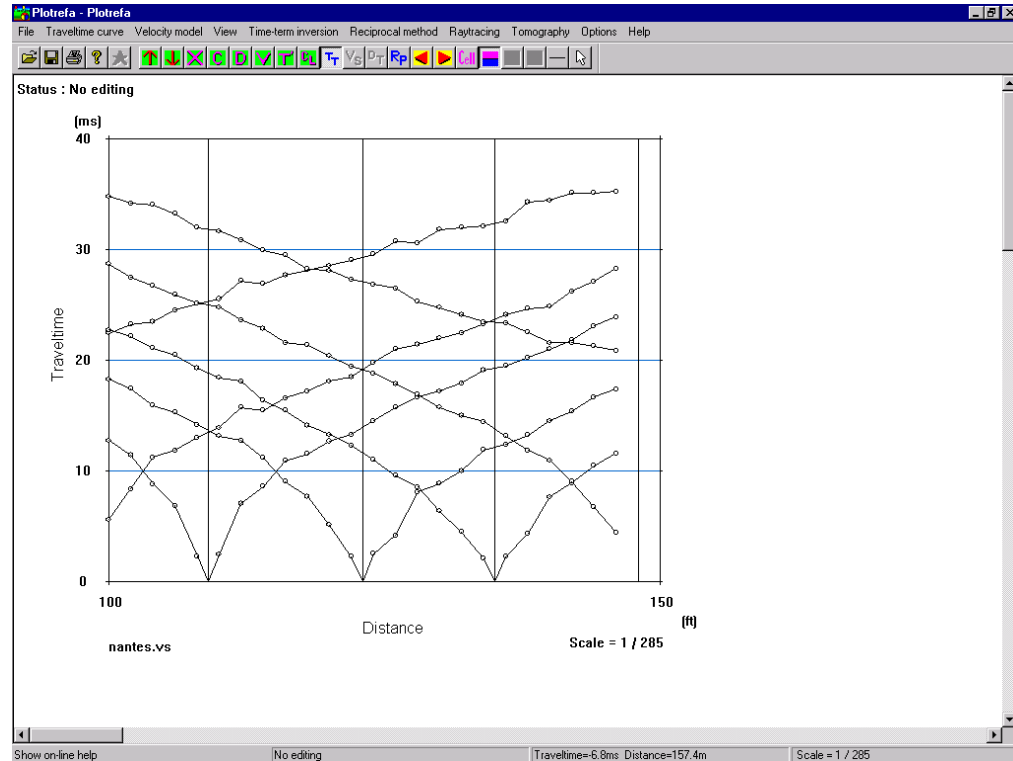

Note: Initial Plotrefa files written by Pickwin are travelttime files only. As you advance through the interpretation, the Plotrefa file will have additional data added to it, such as elevations, layer assignments, and a velocity model.

4.1.2 Append Plotrefa File

If you have multiple spreads, you may append them together in Plotrefa. Open the first Plotrefa file:

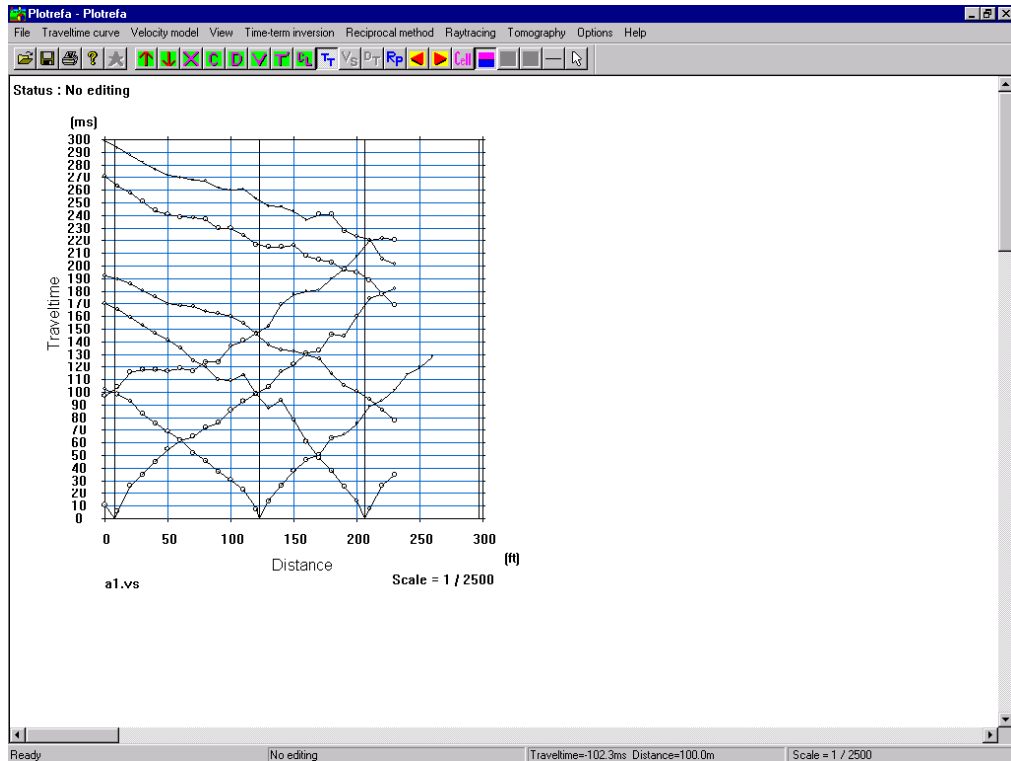

Next, click on “Append Plotrefa file”. You will be presented with a dialog box like the one shown below:

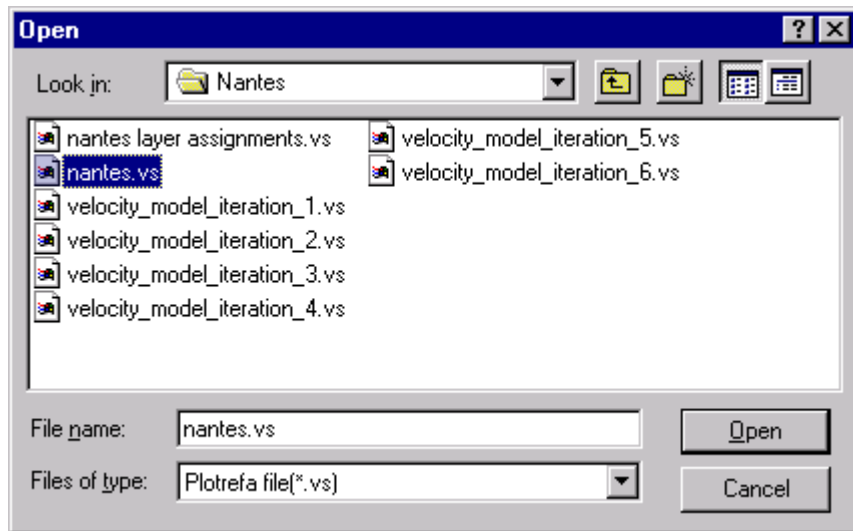

Choose the appropriate .vs file to append, and double-click:

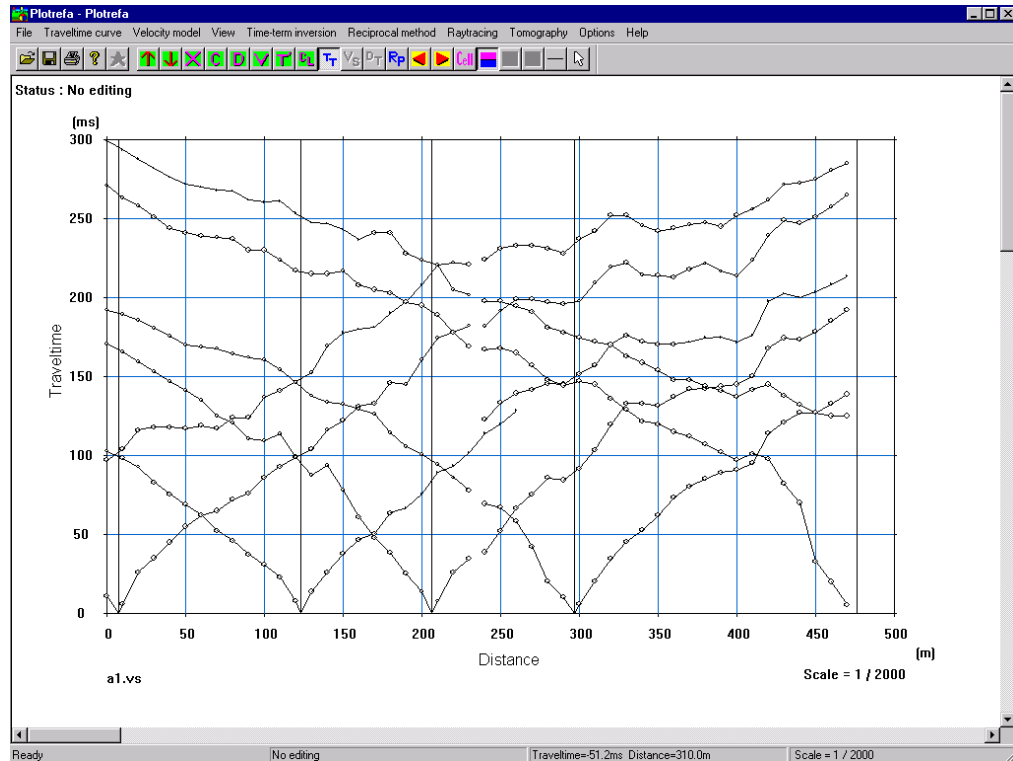

The two files will be appended together as shown above. You may append any number of files.

*Note: Appending must be done **before** creating a velocity model. You may not append velocity models, only traveltime plots.*

4.1.3 Save Plotrefa File

To save a Plotrefa file after editing, choose “Save Plotrefa file”, or press the “Save file” tool button . You will be presented a dialog box like the one below:

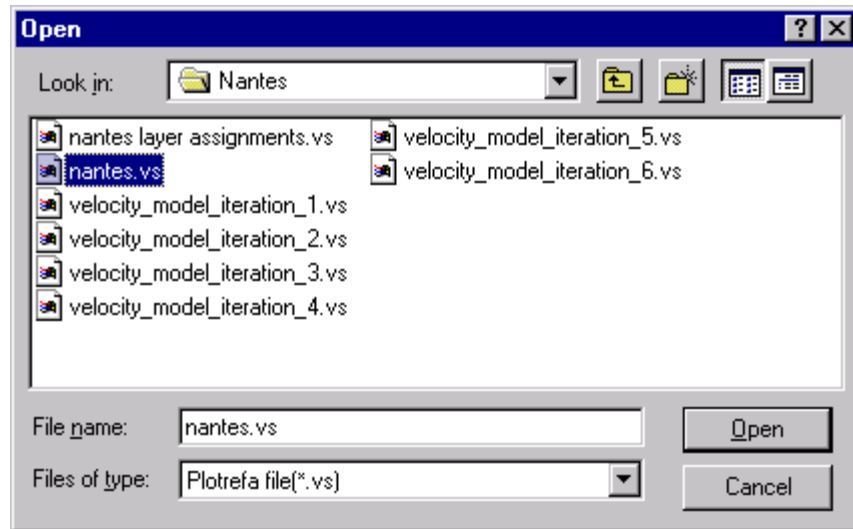

Choose a file name and press *Save*. The extension will default to “vs”.

4.1.4 Open .bpk Files (Field First Breaks)

If you picked your first breaks in the field using the Geometrics first-break picker, you may read them in here – there is no need to re-pick them. Click on “Open bpk files (field first breaks)”. A dialog box will appear, displaying only .bpk files. Choose the files you would like to read in by holding down the control key and clicking on them:

Click on **Open** to display the traveltime data:

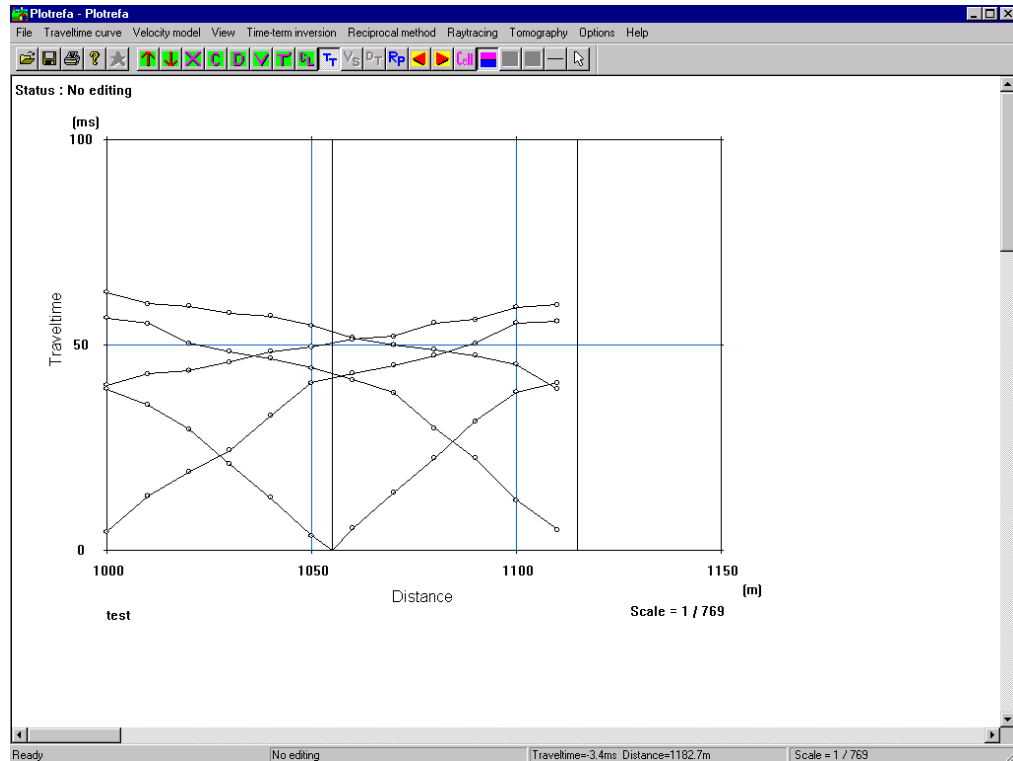

4.1.5 Open .pik files (SIPT2 First Breaks)

If the data have been picked with the RimRock Geophysics SIPT2 picker, the resulting .pik files may be read in by Plotrefa in the same fashion as .bpc files (previous section).

4.1.6 Open .lpc Files (SIPQC Output)

If you ran SIPQC in the field and assigned layers to the arrivals, an .lpc file was created. This simply groups together all the traveltimes for the spread into one file. To read in an .lpc file, choose “Open lpc files (SIPQC output)” and double-click on the appropriate .lpc file. You will see a traveltime plot consisting of several shots, like the one shown in the previous section.

4.1.7 Import Elevation Data File

If you measured relative or absolute geophone elevations, these should be stored in an ASCII-columnar file as shown below:

The left column is the geophone location, and the right column is the elevation. You may read in this elevation file and incorporate it into your velocity model. Click on “Import elevation data file” and double-click on the appropriate file (there is no default extension for elevation files). The elevation profile will be displayed:

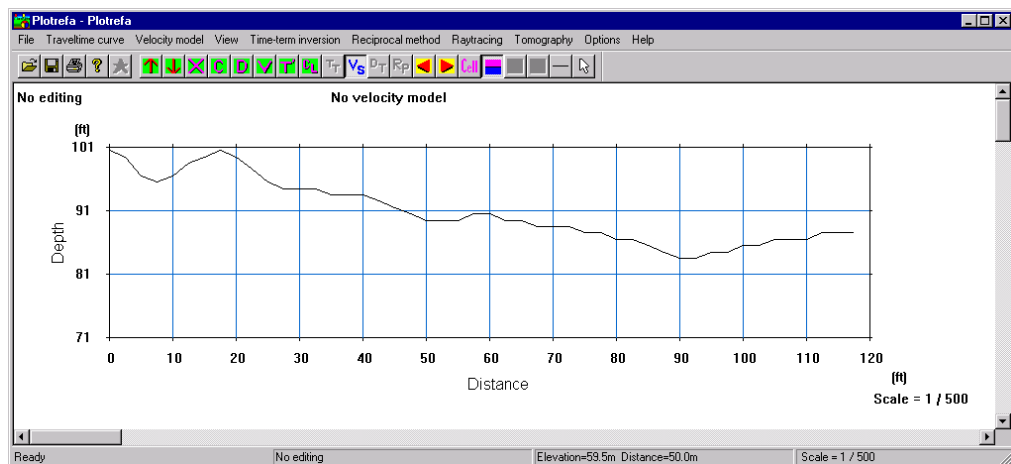

After interpreting your data and calculating the velocity structure, it will be drawn relative to the elevation profile, as shown below:

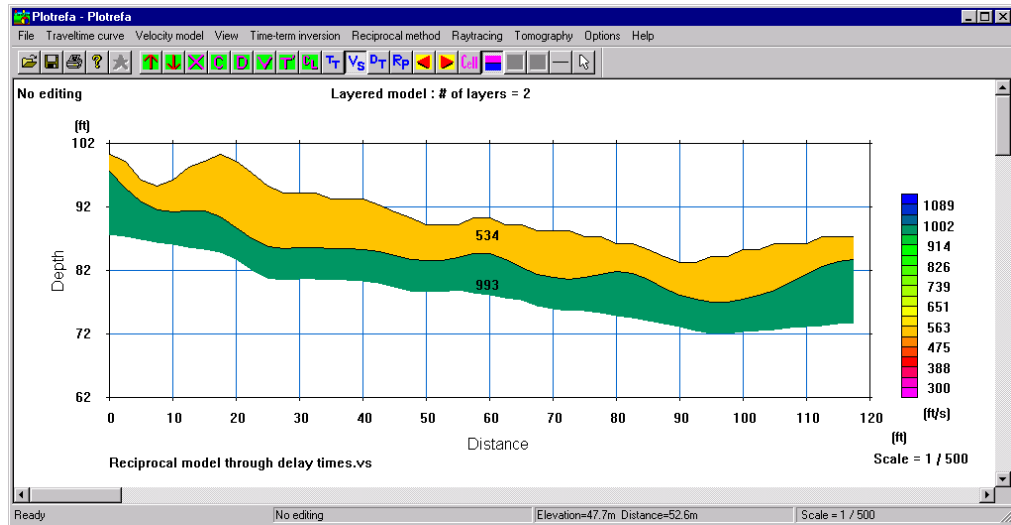

4.1.8 Open Borehole Data File

4.1.9 Save Traveltime Curves (DXF Format)

You may save the traveltime curves to a .DXF file for custom editing with standard CAD software. This allows you to put your personal touch on the output. Click on “Save traveltime curves (DXF format)”. You will be presented with the following dialog box:

Choose the appropriate options and press **OK**. The file will default to a .DXF extension.

4.1.10 Save Velocity Model (DXF Format)

This function is identical to that described above, but outputs the velocity model in DXF format.

4.1.11 Save velocity file as the Surfer™ format (.txt)

If you do a tomographic analysis, you can save the file in an ASCII columnar xyz format for import into third-party graphics programs such as Surfer™.

67.500000	-4.000000	0.576237
67.500000	-4.770833	0.576237
67.500000	-6.312500	1.633451
67.500000	-7.854167	2.605853
67.500000	-9.395833	2.679835
67.500000	-10.937500	2.743473
67.500000	-12.479166	2.759478
67.500000	-15.947916	2.837538
67.500000	-19.416666	2.837538
67.500000	-22.885416	2.837538
67.500000	-26.354166	2.837538
67.500000	-29.822916	2.837538
67.500000	-33.291664	2.837538
67.500000	-36.760414	2.837538
67.500000	-40.229164	2.837538
74.000000	-3.000000	0.576246
74.000000	-3.778247	0.576246
74.000000	-5.334741	1.619895
74.000000	-6.891235	2.604389
74.000000	-8.447729	2.683146
74.000000	-10.004223	2.736959
74.000000	-11.560717	2.759478
74.000000	-15.062828	2.837538
74.000000	-18.564939	2.837538
74.000000	-22.067051	2.837538

4.1.12 Save analysis result as text format (.txt)

If you wish to output your data in a tabular format, choose “Save analysis result as text format”:

The spread contains 7 shotpoints and 24 geophones										
SP	Elev	X-loc	Y-Loc	Depth						
1	-3.62	70.00	0.00	0.00						
2	0.69	98.00	0.00	0.00						
3	6.50	109.00	0.00	0.00						
4	4.00	123.00	0.00	0.00						
5	-5.00	135.00	0.00	0.00						
6	1.37	148.00	0.00	0.00						
7	6.54	176.00	0.00	0.00						
Geo	Elev	X-loc	Y-Loc	SP 1	SP 2	SP 3	SP 4	SP 5	SP 6	SP 7
1	1.00	100.00	0.00	22.31 1	5.44 1	13.13 1	18.25 1	22.38 1	28.13 1	34.00 1
2	2.00	102.00	0.00	22.50 1	8.69 1	11.69 1	17.50 1	21.81 1	27.38 1	33.81 1
3	4.00	104.00	0.00	22.94 1	11.19 1	9.00 1	16.50 1	21.00 1	26.50 1	32.81 1
4	6.00	106.00	0.00	23.69 1	12.38 1	7.29 1	15.63 1	20.50 1	25.75 1	32.75 1
5	7.00	108.00	0.00	24.25 1	13.69 1	2.50 1	14.31 1	18.94 1	24.81 1	31.88 1
6	6.00	110.00	0.00	25.00 1	14.31 1	2.94 1	13.38 1	18.94 1	23.88 1	31.38 1
7	7.00	112.00	0.00	26.69 1	15.21 1	7.81 1	13.38 1	18.63 1	24.25 1	31.50 1
8	8.00	114.00	0.00	26.06 1	15.48 1	8.81 1	11.00 1	16.69 1	22.56 1	30.25 1
9	10.00	116.00	0.00	27.00 1	16.75 1	11.06 1	9.13 1	15.81 1	21.69 1	30.00 1
10	8.00	118.00	0.00	27.44 1	18.00 1	11.69 1	7.69 1	14.63 1	20.81 1	28.00 1
11	7.00	120.00	0.00	28.00 1	17.81 1	12.94 1	4.94 1	13.50 1	20.25 1	27.50 1
12	5.00	122.00	0.00	28.38 1	18.25 1	13.69 1	2.06 1	12.13 1	19.88 1	26.88 1
13	3.00	124.00	0.00	29.50 1	20.06 1	14.77 1	2.44 1	11.31 1	18.81 1	26.69 1
14	0.00	126.00	0.00	30.13 1	20.50 1	15.88 1	4.77 1	9.88 1	18.31 1	26.00 1
15	-2.00	128.00	0.00	30.88 1	21.06 1	16.94 1	8.31 1	8.69 1	16.63 1	25.13 1
16	-3.00	130.00	0.00	31.13 1	21.44 1	16.81 1	9.25 1	6.56 1	15.69 1	24.19 1
17	-4.00	132.00	0.00	31.31 1	22.19 1	18.19 1	9.88 1	4.31 1	15.38 1	23.75 1
18	-5.00	134.00	0.00	31.88 1	22.81 1	18.38 1	11.50 1	2.52 1	14.25 1	23.56 1
SP	X-loc	Layer 2								
1	70.00	3.14								
2	98.00	3.14								
3	109.00	3.49								
4	123.00	3.89								
5	135.00	2.15								
6	148.00	4.94								
7	176.00	4.94								
Geo	X-loc	Layer 2								
1	100.00	3.14								
2	102.00	3.43								
3	104.00	4.11								
4	106.00	4.49								
5	108.00	4.28								
6	110.00	2.70								
7	112.00	3.30								
8	114.00	3.45								
9	116.00	4.77								
10	118.00	3.21								
11	120.00	3.67								
12	122.00	3.76								
13	124.00	4.01								
14	126.00	2.87								
15	128.00	2.26								
16	130.00	2.39								
17	132.00	2.36								
18	134.00	2.01								

4.1.13 Print

To print the window display of Plotrefa, choose “Print”, press **CTRL-P**, or press the “Print” tool button . You will see the print dialog box for your computer:

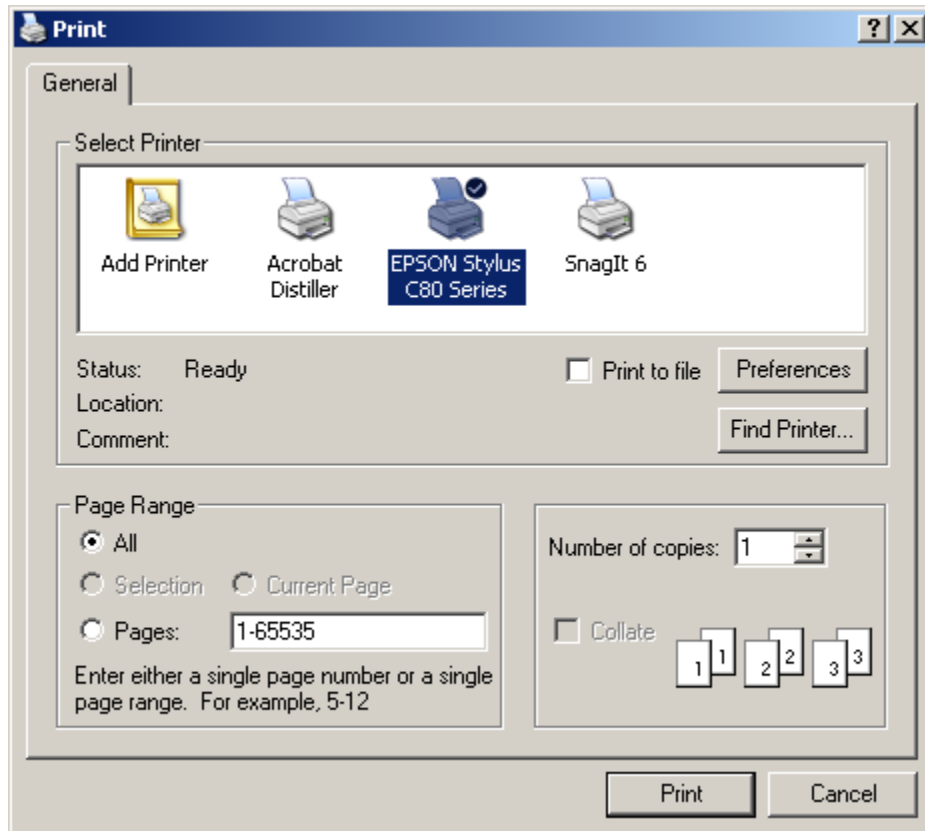

Click **OK** to print the current window display of Plotrefa.

4.1.14 Print Preview

To preview the window display of Pickwin for printing, choose “Print preview(V)”. You will see a preview of the window display that will be printed:

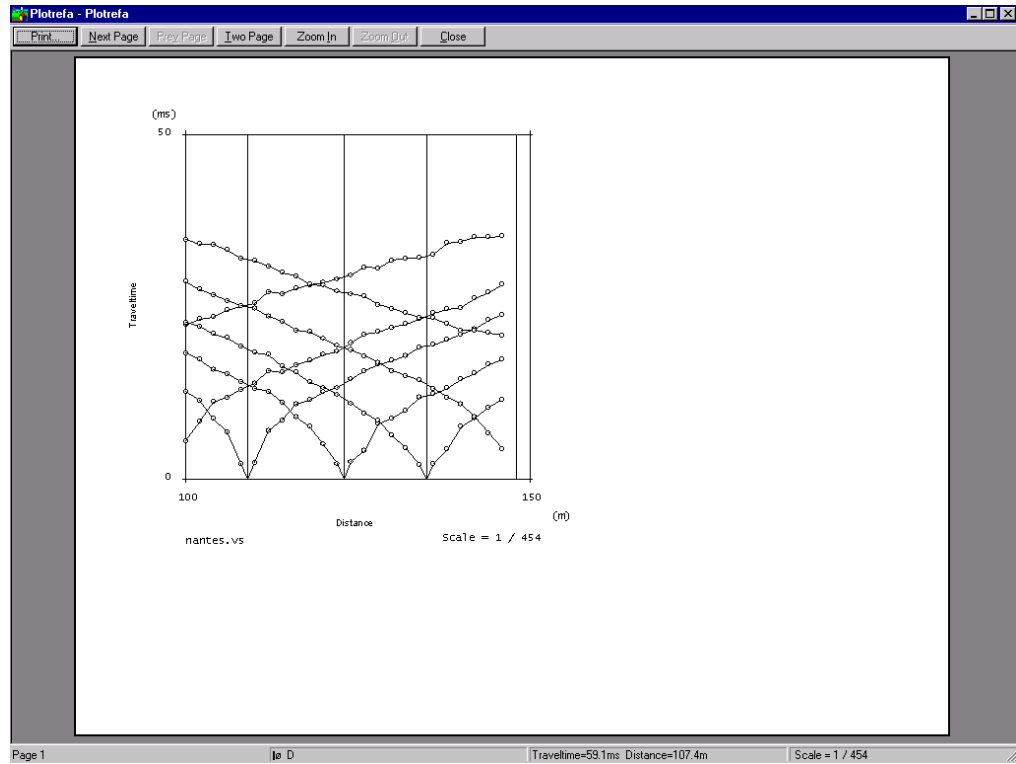

To print this display, click **Print**. To close this display, click **Close**.

4.1.15 Page Setup

To set up a page for printing, choose "Page set up(R)". You will see the print dialog box for your computer:

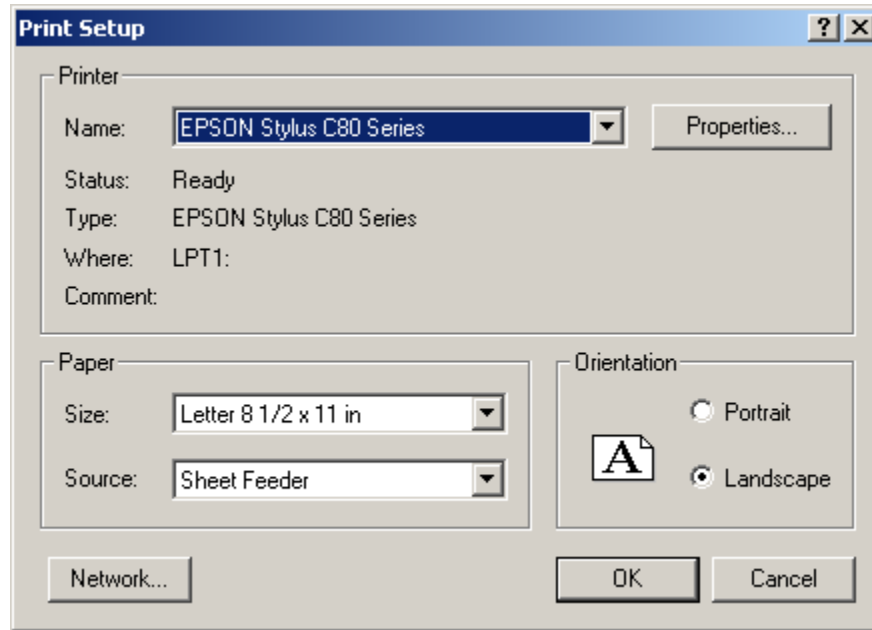

Adjust the properties for printing or click **OK** to print the current window display of Plotrefa.

4.1.16 Exit Program

To exit the Plotrefa module, choose “Exit program (X)”. You will see the following dialog box:

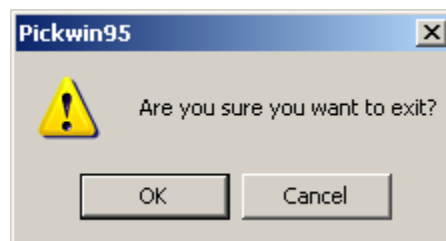

Press **OK** to exit Plotrefa or press **Cancel** to continue using Plotrefa.

4.2 *Traveltime Curve Menu*

Click on “Traveltime curve” to reveal the **Traveltime Curve** menu:

4.2.1 *Exit Edit Mode*

When you are not in an edit mode, you can click and drag your mouse on the graph to measure time distances, as shown below:

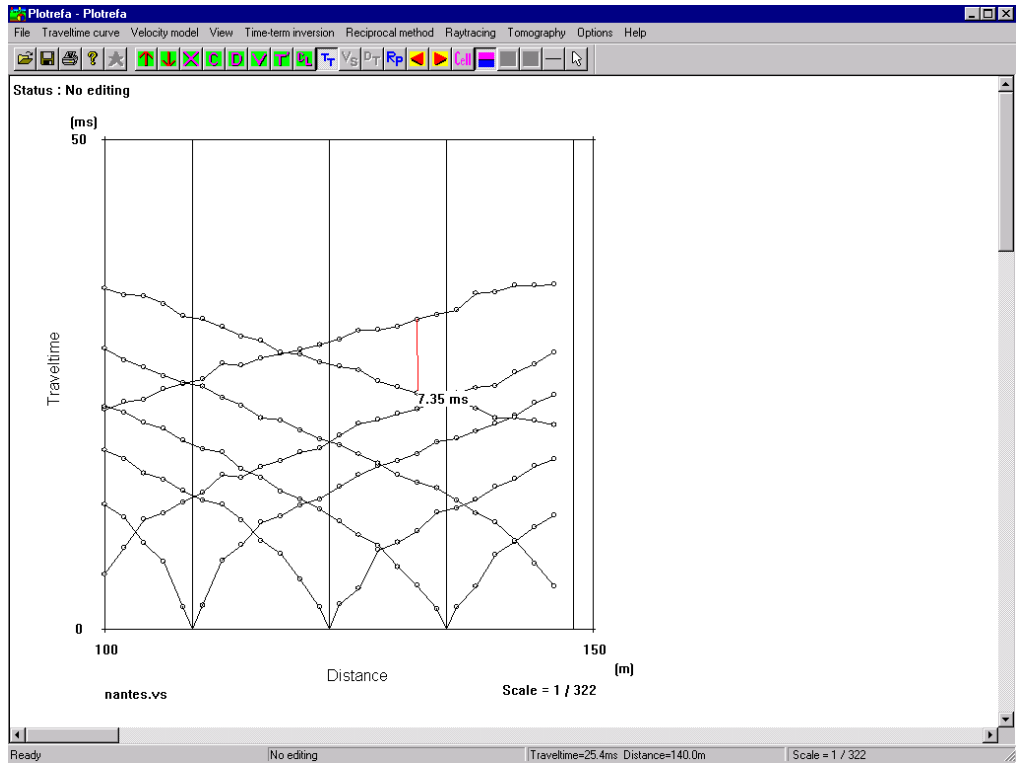

Also, if you double-click on a traveltime, the shot location and depth for that traveltime curve will be displayed and can be edited if necessary:

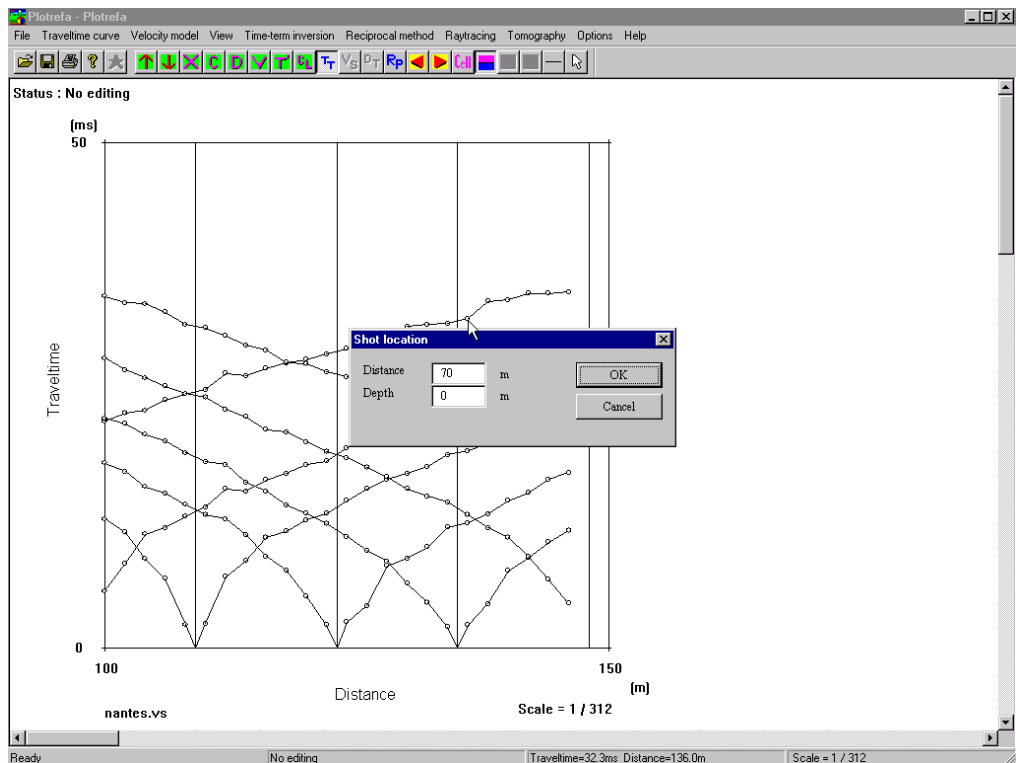

You may also draw a velocity line on your traveltimes plot by clicking on the tool button and clicking and dragging your mouse. The velocity of the line will be displayed dynamically at the top of the display. Right click to “set” the velocity line:

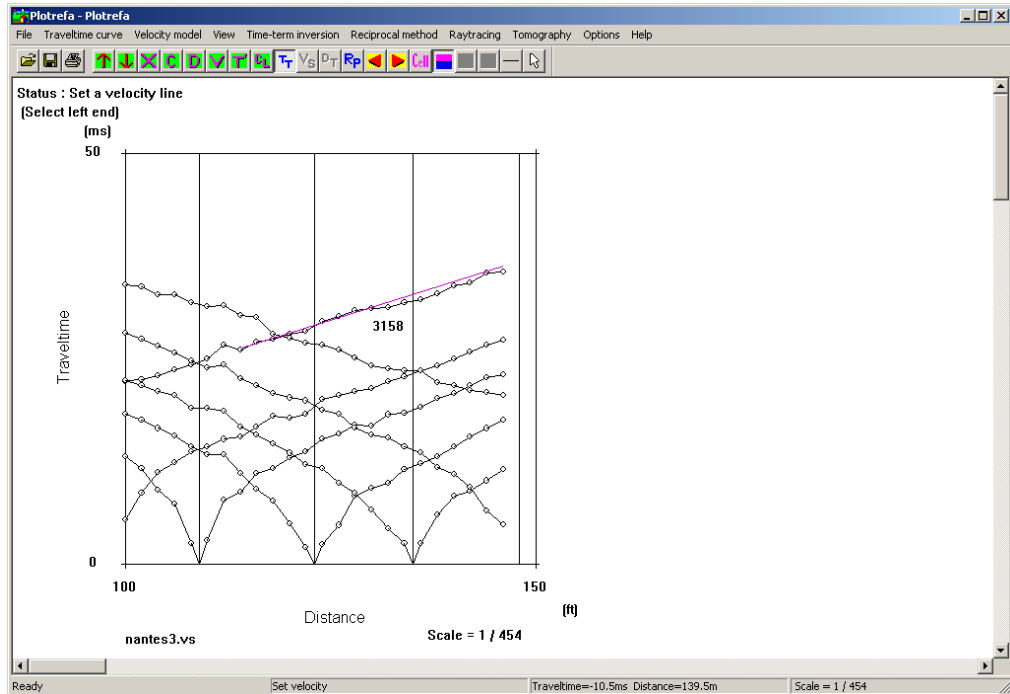

If you are in an edit mode (for instance, modifying traveltimes), clicking and dragging the mouse will alter your data, depending on the specific edit mode you are in. To get out of edit mode, choose “Exit edit mode”, or press the tool button.

4.2.2 Modify Traveltimes (All Shots)

You may use Plotrefa to modify traveltimes if necessary. If you choose “Modify traveltimes (all shots)”, you can then click and drag any traveltime to a new position. Simply point at the traveltime you wish to change, and click. The selected traveltime will turn red:

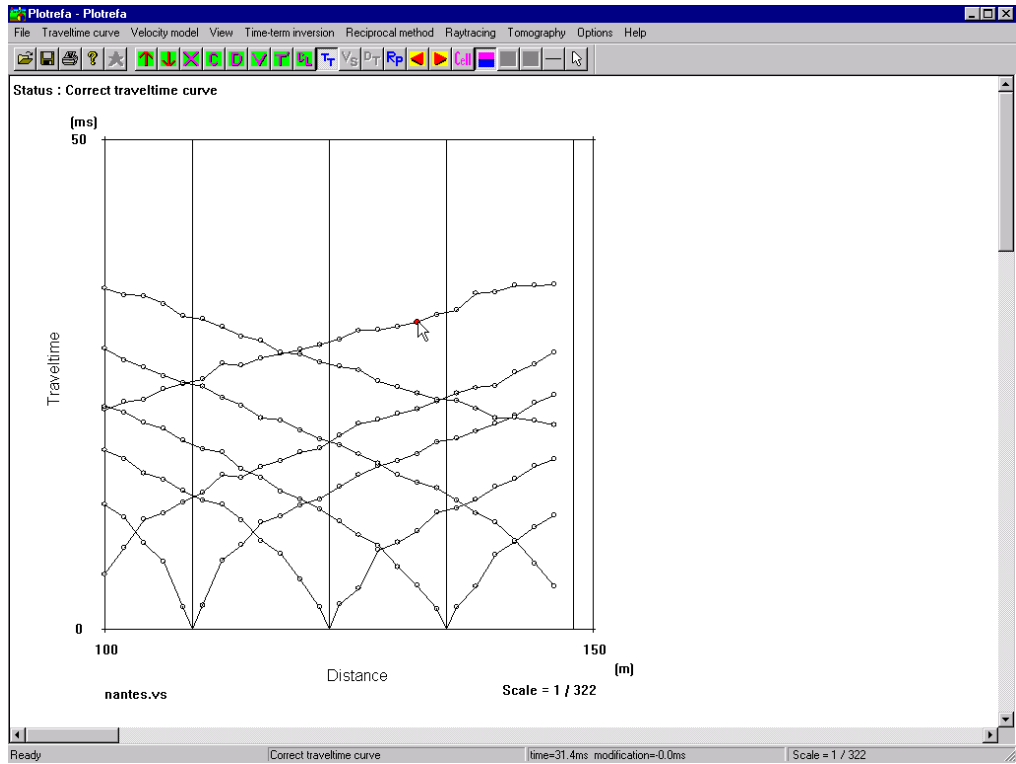

While holding the button down, drag the cursor to where you want the traveltine to be, and release:

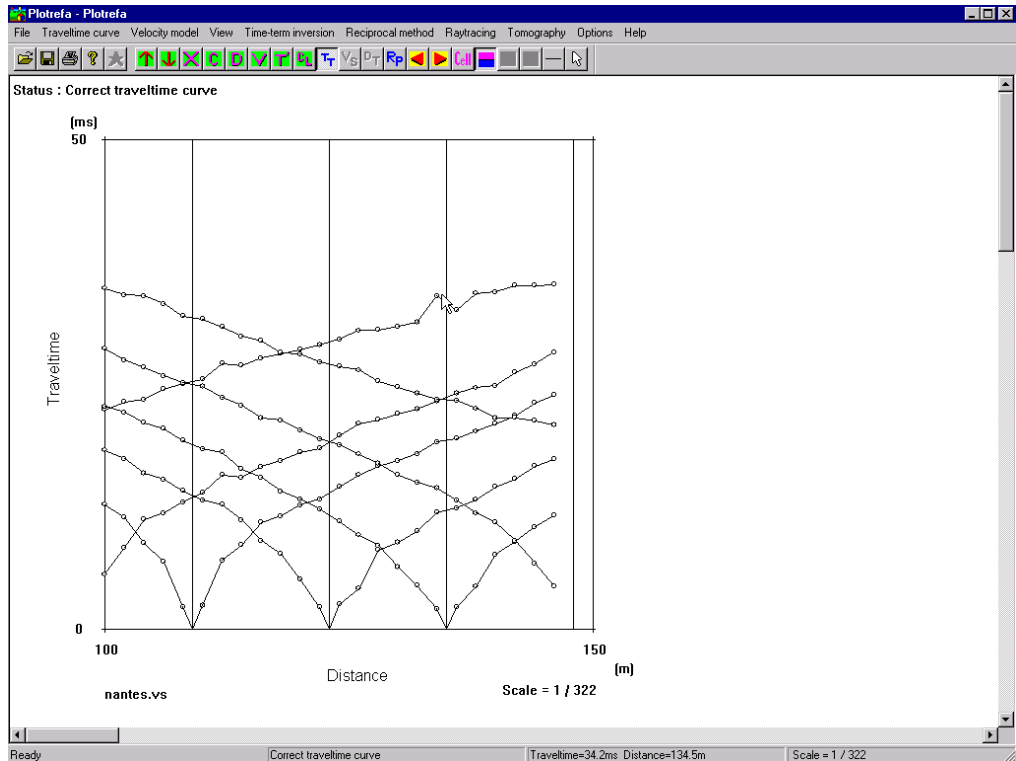

4.2.3 Modify Traveltimes (Individual Shot Only)

Sometimes two traveltimes plot on top of each other, making it difficult to take control of the one you want. When this happens, you can choose “Modify traveltimes (individual shot only)”. This allows you to first choose the traveltime curve that contains the traveltime you wish to modify. Simply click on the traveltime curve, and it will change color:

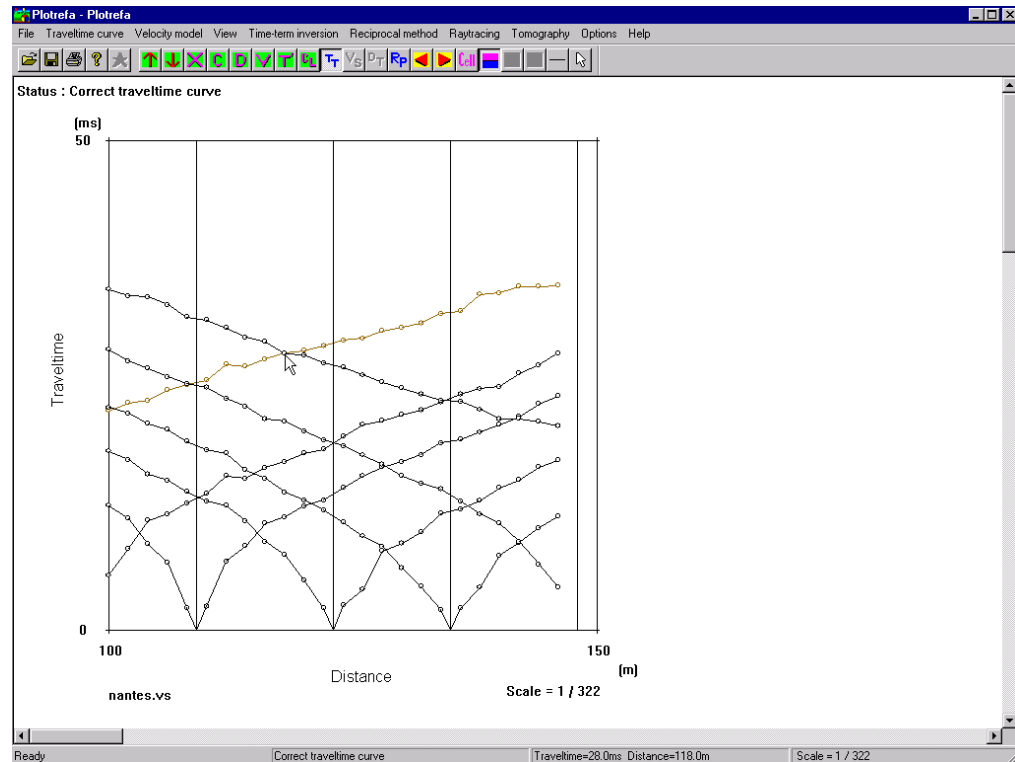

Now, only traveltimes on that particular curve can be selected for modification. Note above that the cursor is pointing to a traveltime that is coincident with a traveltime on another curve. But only the one in the highlighted curve can be modified. Click and drag the traveltime as described above.

*Note: You will notice that the curve is no longer highlighted. This feature turns itself off after adjusting one traveltime, i.e., **all** traveltimes are accessible after the first one is modified. You must choose “Modify traveltimes (individual shot only)” again to highlight another curve.*

4.2.4 Shift a Traveltime Curve

You may also shift an entire traveltime curve. Choose “Shift a traveltime curve”, click and hold on the curve of interest (it will change colors), and drag it to the new position:

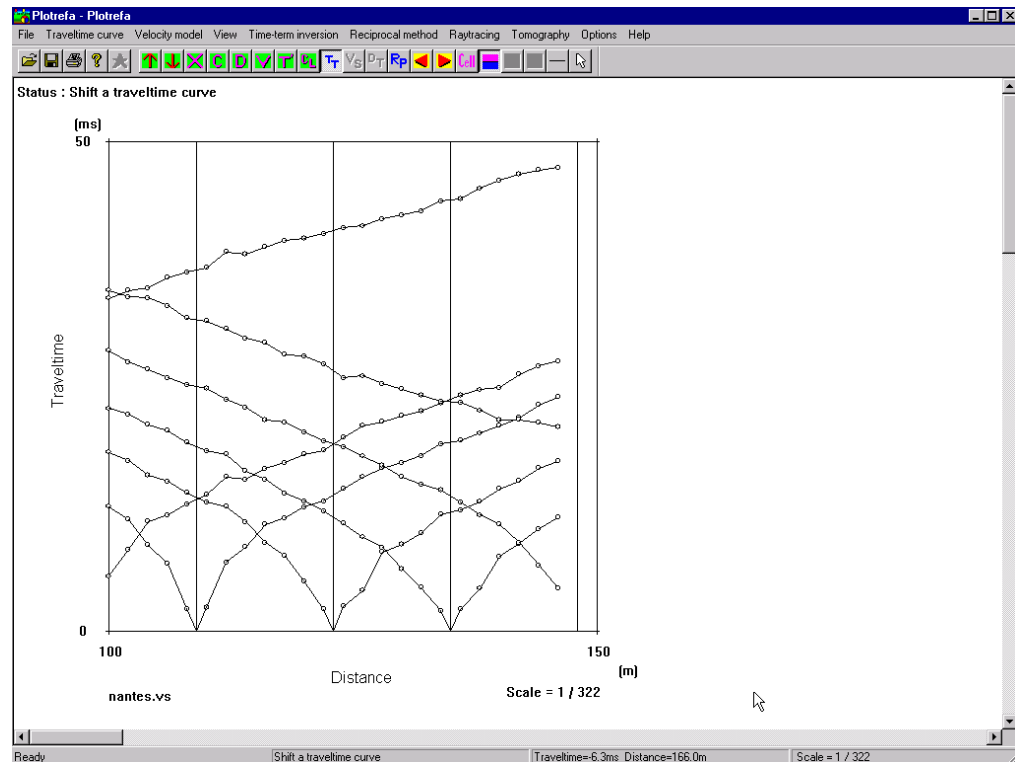

The entire curve highlighted in the previous section has been moved to a later time.

4.2.5 Calculate Traveltime Difference Curve

When assigning layers to first arrivals, it is often useful to construct a traveltime difference curve. The difference curve for two shots from the same direction will be flat where the traveltimes are coming from the same layer. This can assist in determining crossover points.

To calculate a difference time curve, choose “Calculate traveltime difference curve”, or press the  tool button. Next, click on the two traveltime curves you wish to calculate the difference time curve for.

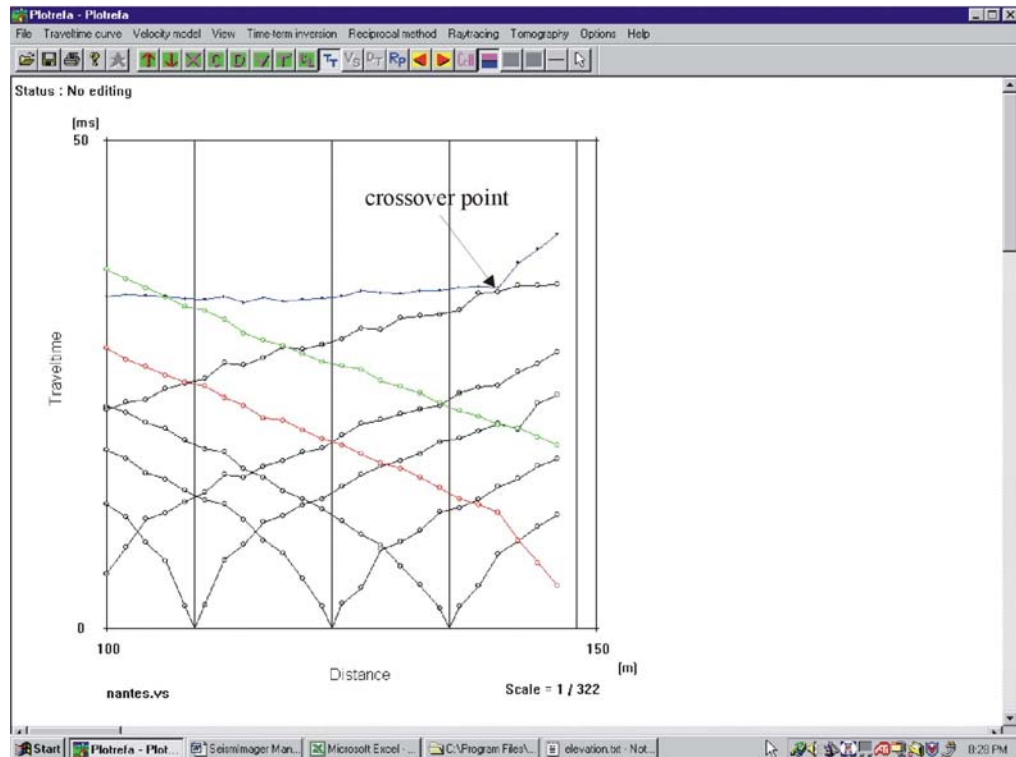

In the example above, the blue curve represents the difference time curve for the highlighted traveltime curves. Note that the crossover point for the red curve is clearly delineated by the difference time curve. This is an extremely useful tool when crossover points are difficult to determine.

To remove the difference time curve, simply press the  tool button.



Audio/video clip of Difference-time Curve Calculation

4.2.6 Check Reciprocal Traveltime

The *Principal of Reciprocity* states that the traveltime measured between a source and receiver is independent of the direction of travel. In other words, if you invert the source and geophone, you must get the same traveltime. This is true regardless of the subsurface conditions – in theory at least, **the traveltimes must be the same.**

Checking for reciprocity in your data is an important step in ascertaining the quality of your data. If you don't have reciprocity within about 5%, you

should recheck your traveltimes. Velocity models calculated from data exhibiting poor reciprocity are likely to be invalid.

Plotrefa will check reciprocity, where appropriate, automatically. Simply choose “Check reciprocal traveltime”, and the program will examine the traveltimes and calculate reciprocity between shots in which the conditions of reciprocity are met.

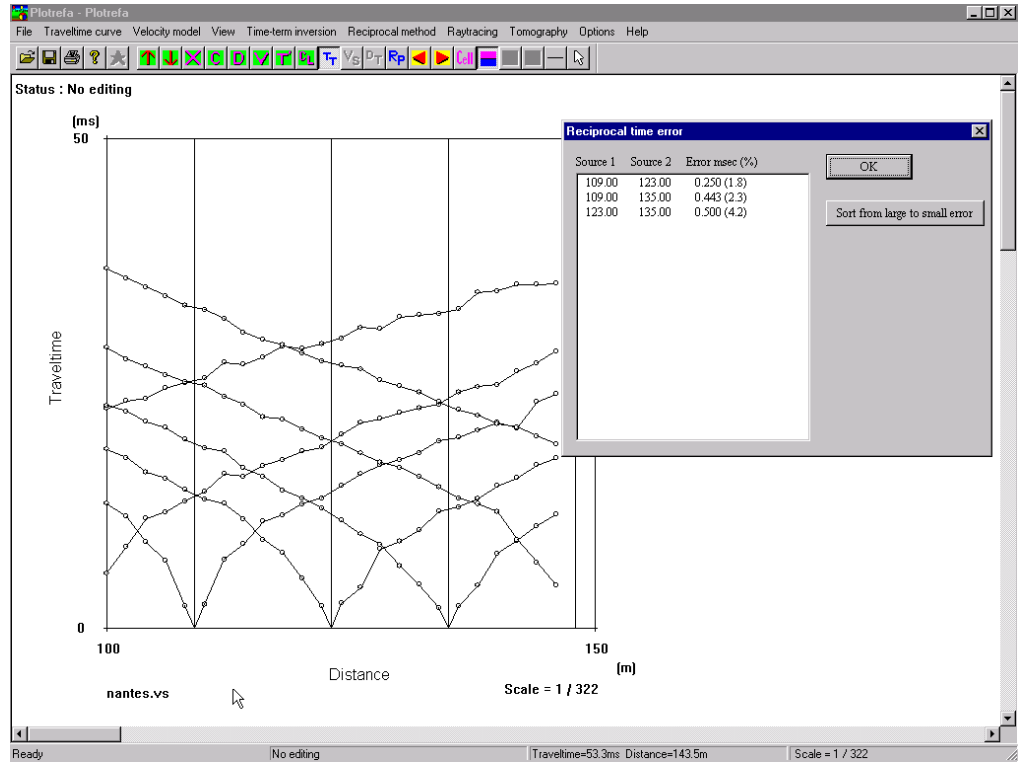

In the example above, the reciprocity has been reported for the three interior shots. Both the absolute and percent errors are reported. The reciprocity report will be saved to a file called “reciprocity_check.txt” in the same folder in which your data are stored.

***Note:** Reciprocal times are calculated only for shots that are within the geophone spread. For this reason, it is recommended that the shots at the end of the spread be located between the two end phones at either end of the line. For instance, with a 24-channel spread, the left end-shot would be between geophones 1 and 2, and the right end shot would be between geophones 23 and 24. SeisImager/2D will interpolate to calculate the reciprocal times at the shot locations.*

4.2.7 Correct Reciprocal Time Automatically

If the data quality is such that you cannot get better than a 5% reciprocity error, it is sometimes helpful to have the program correct the data. This, of course, is no substitute for picking the data correctly. It should only be used when true reciprocity cannot be achieved, because of difficulty in picking first breaks. The program will iteratively shift the traveltime curves to spread the reciprocity error out as evenly as possible, and this will sometimes yield a better answer than if left alone.

To correct the reciprocal times, choose “Correct reciprocal time automatically”:

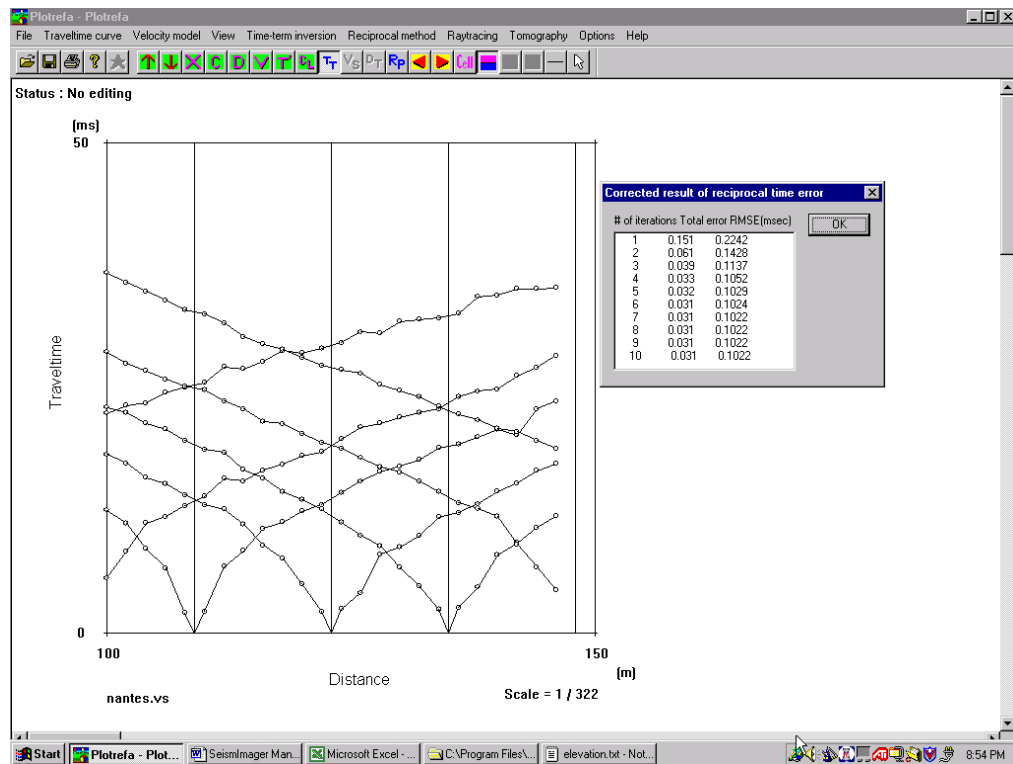

The traveltimes will be shifted to minimize the errors, and a table of total error versus iteration number will be displayed. Press **OK**, and a new reciprocity report will be shown:

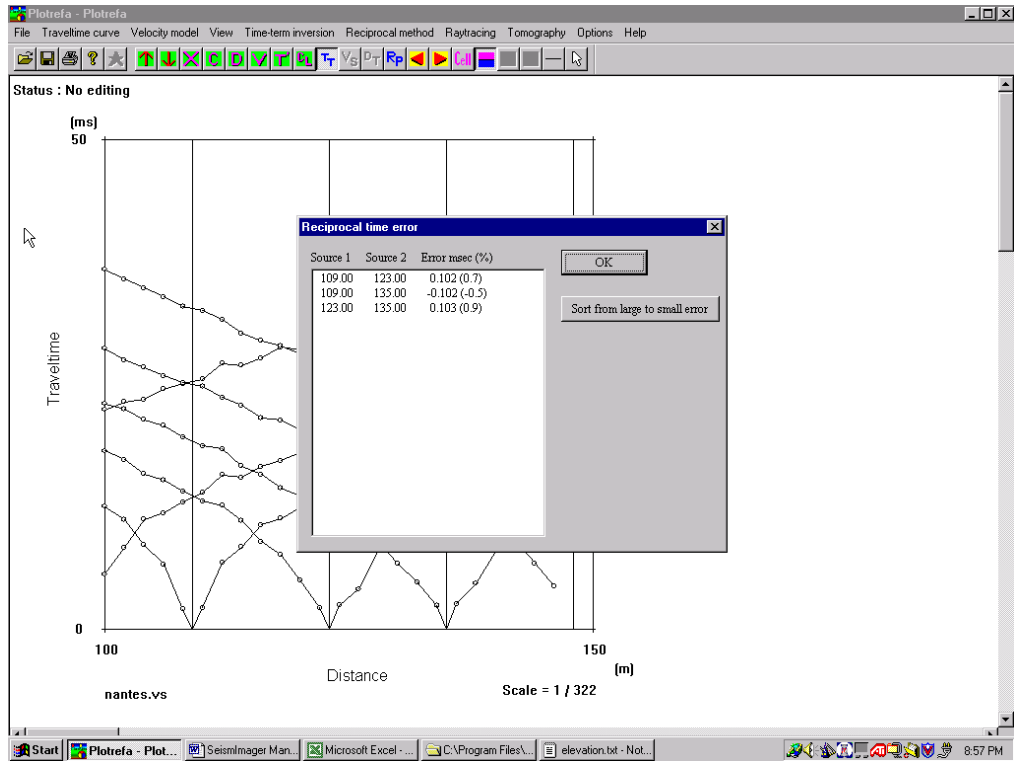

Note: The amount of confidence in the resulting model should be inversely proportional to the level of correction required. A model calculated from modified data is always suspect.

4.2.8 Connect Common Source Traveltime Curves

If you have appended Plotrefa files together, as discussed in [Section 4.1.2](#), you may connect the traveltime curves from common sources together. In the example below (the same used in Section 4.1.2), two separate Plotrefa files have been appended. However, that they are still shown as separate curves (note the gaps in the middle). Before proceeding to the layer assignment phase, these traveltime curves should be connected. You may do so by simply clicking on “Connect common source traveltime curves”.

Note that this feature does **not** make any corrections to the data. If there are source-dependent offsets, such as those discussed in [Section 3.2.8](#), they should be corrected manually by using the “Shift a traveltime curve” function.

In the example below, two Plotrefa files have been appended:

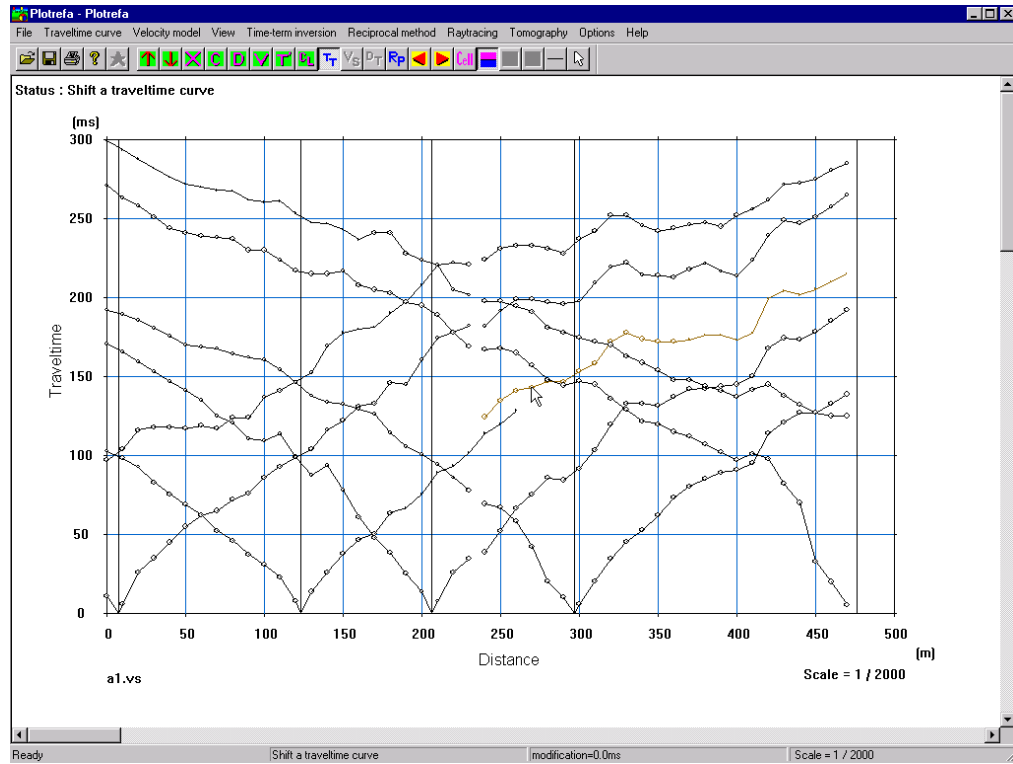

The highlighted traveltime curve needs to be adjusted in time before doing so. Otherwise, the final interpretation will include an artifact due to a sudden and false jump in traveltime at that location. In the figure below, the highlighted traveltime curve has been moved down to better agree with its common-source data:

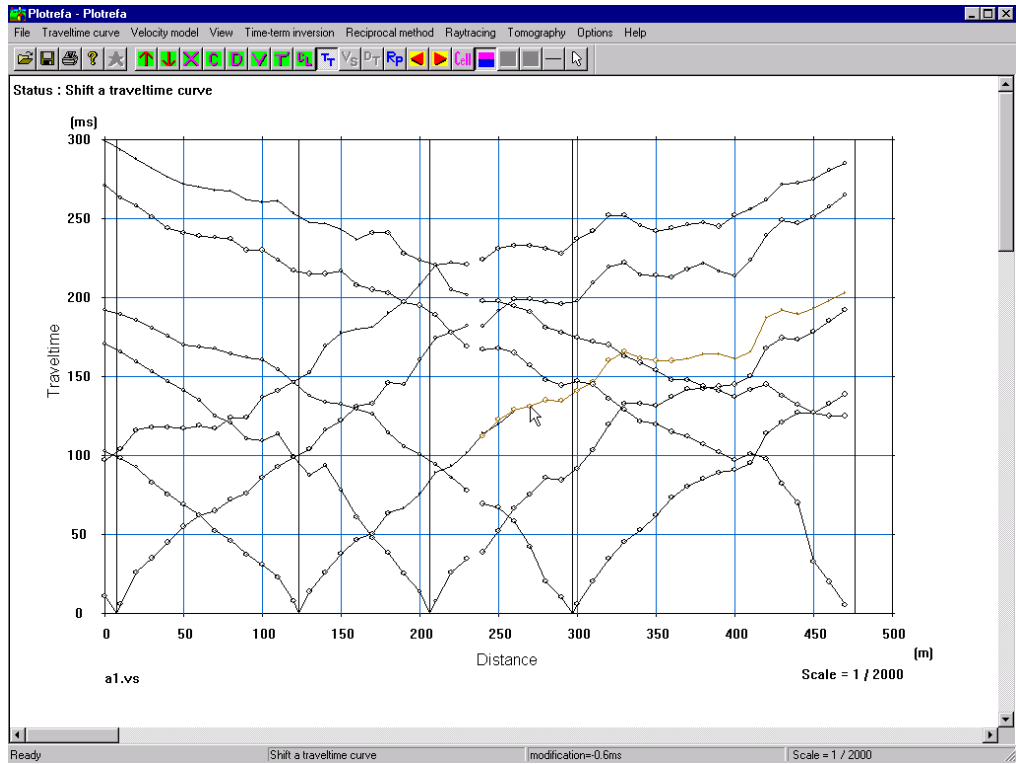

After manually correcting where necessary, you may connect the traveltme curves:

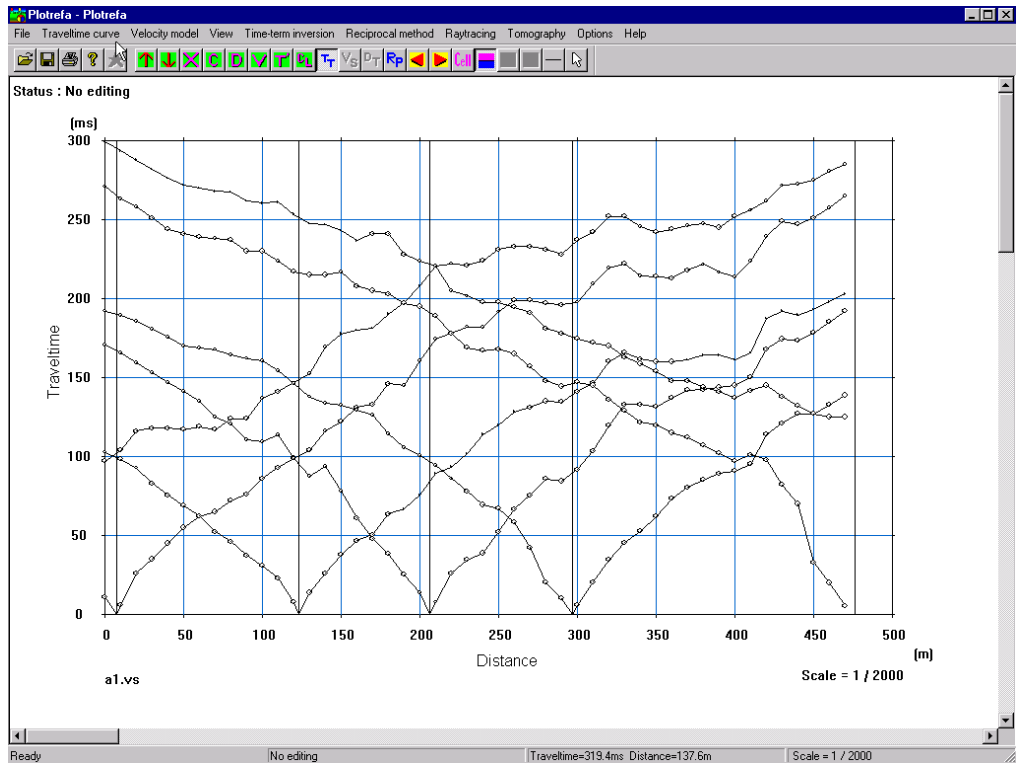

You now have a travelttime plot that should be exactly the same as the one you would have achieved had you laid out the geophones once, and occupied all of the shot points once.

At this point, it should be obvious why overlap is highly desired when using multiple spreads. As shown in [Section 3.2.8](#), this same step can be accomplished in Pickwin. Where you do it is a matter of preference. But no matter how you do it, overlapping geophones is essential to correct for inconsistencies at the shot.

4.2.9 Delete a Traveltime

You may delete a traveltimes by choosing “Delete a traveltimes” and clicking on it:

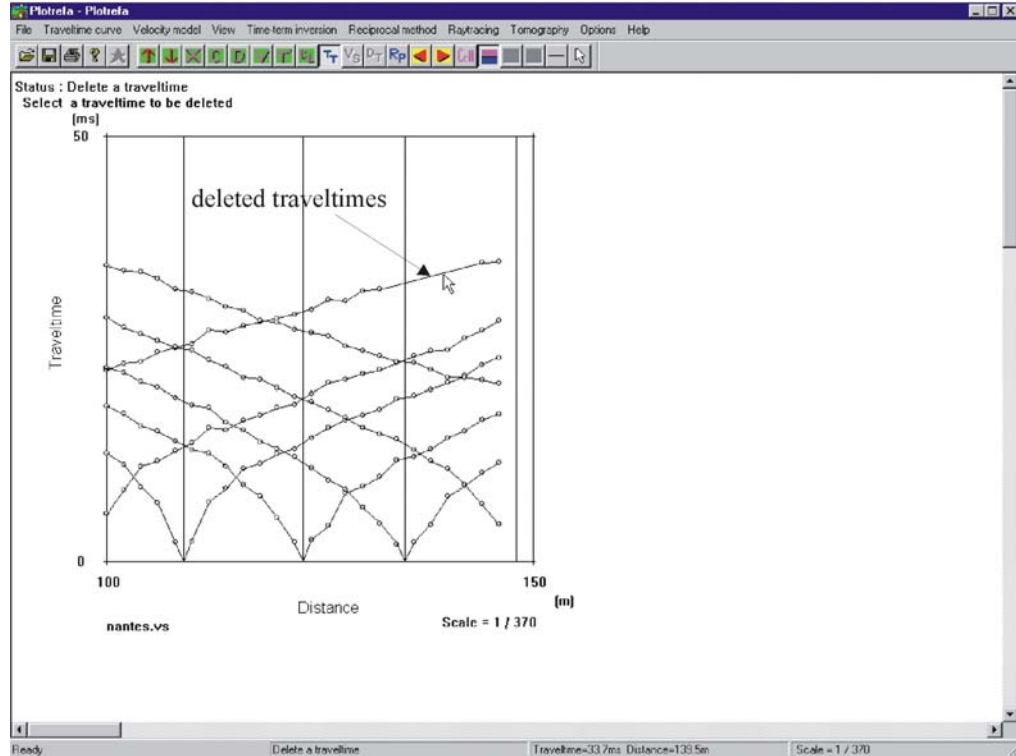

In the above figure, five traveltimes have been deleted.

4.2.10 Correct Traveltime Curve For Shot Offset

If the shot is beneath the surface and/or offset from the line, you may correct the traveltime curve to account for it. In general, this is good practice when the shot depth/offset is more than 20% of the geophone spacing. Choose “Correct traveltime curve for shot offset”, and you will see the following dialog box:

Input the source location (long the line), depth, and offset (perpendicular to the line), and the traveltimes will be corrected, using the near-surface velocity, to what they *would* be if the source were on the surface at zero perpendicular offset.

In the example below, the center shot of the data set shown above has been corrected for a 2-meter offset:

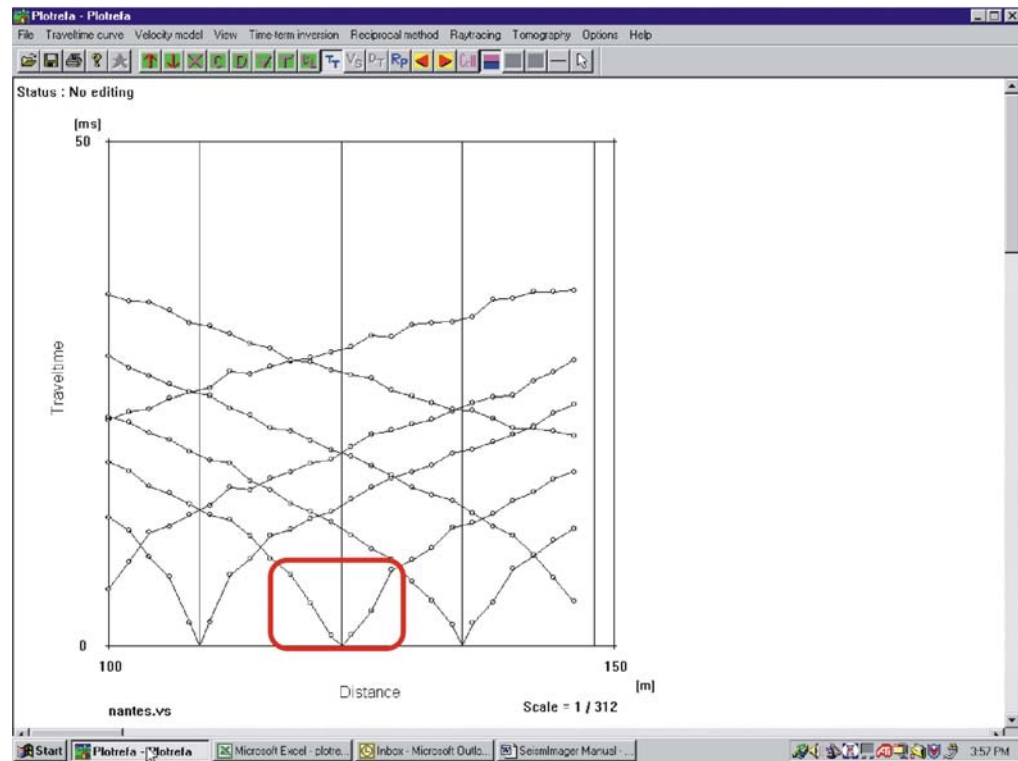

The geophones closest to the shot are most affected by this correction (compare to uncorrected data).

4.2.11 Display

The display contains a sub-menu which allow you to control various display parameters of the traveltime plot. All of these choices are toggle switches; you simply click on them to turn them on or off.

If you have done your layer assignments, you may color-code them by choosing “Show layer assignments”:

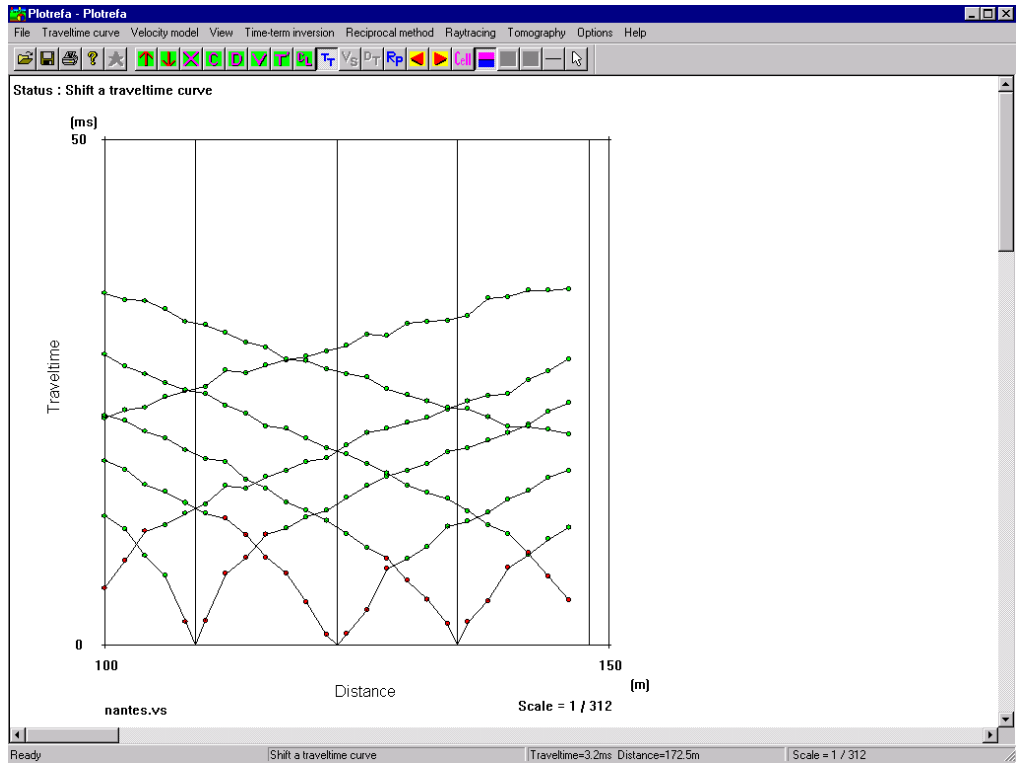

If you would like to differentiate the shot gathers, you may color them different colors. Just click on “Color traveltine curves”:

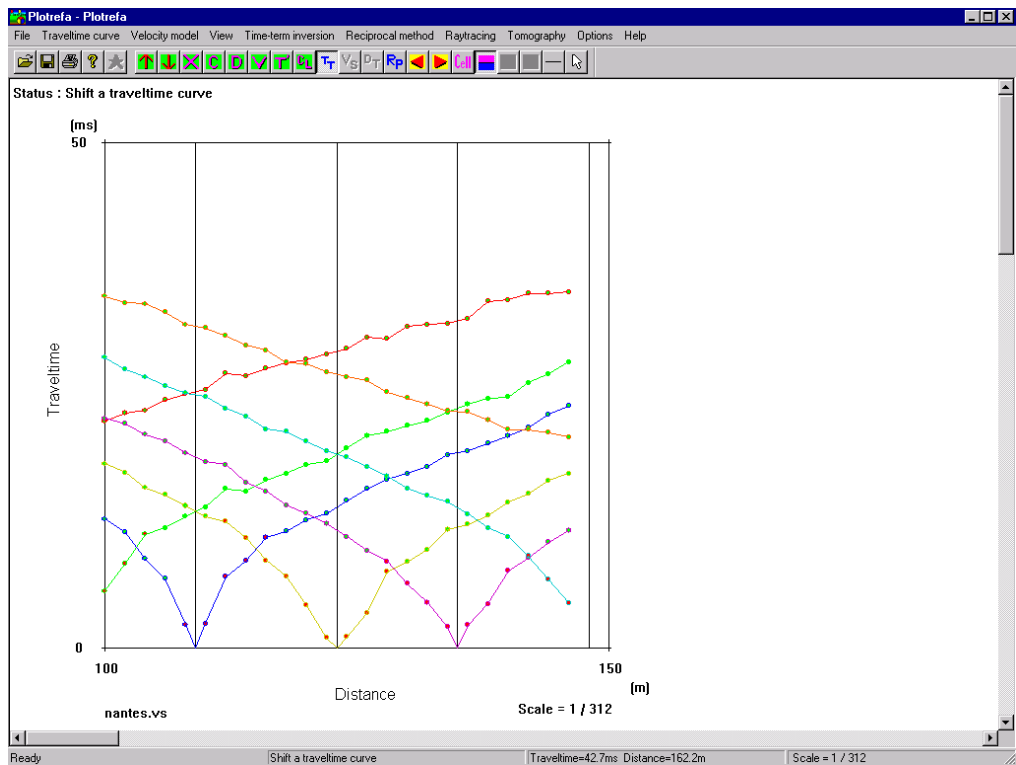

You may choose whether or not to connect the sources to the near geophones.
Below is the same plot without the “source lines” drawn:

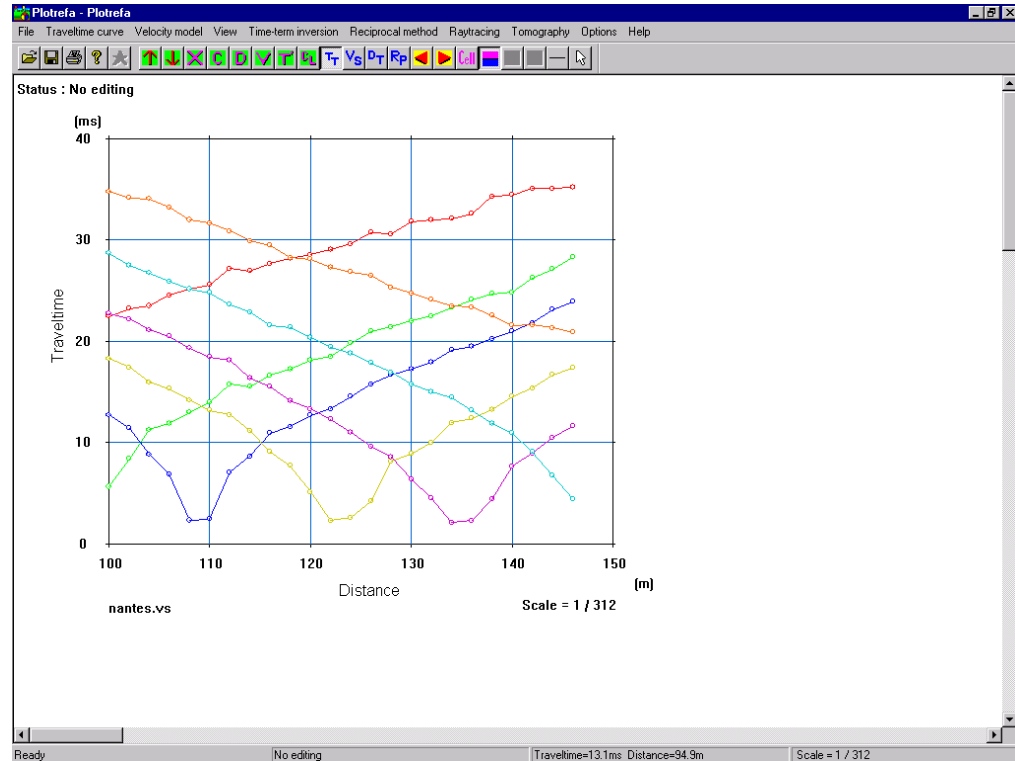

Note: Source lines are only shown for shots within the geophone spread.

If you have traced rays through your velocity model, the traveltime plot will default to displaying both the observed and theoretical data:

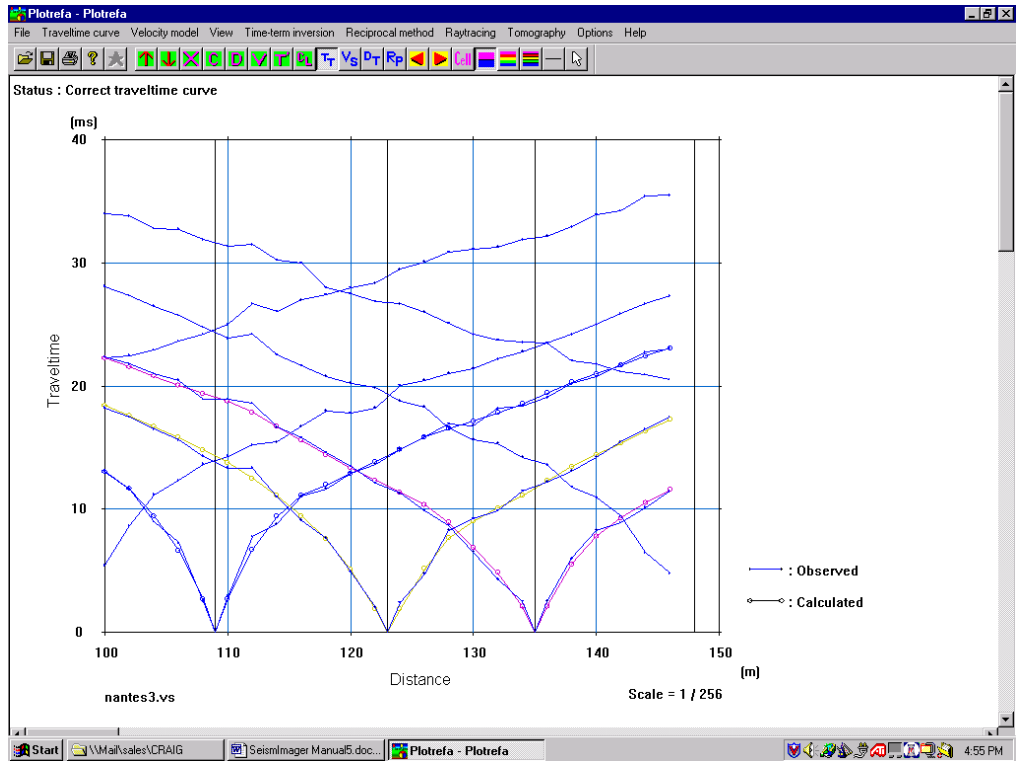

If you wish to only see the theoretical data, click on the “Show observed data” toggle switch:

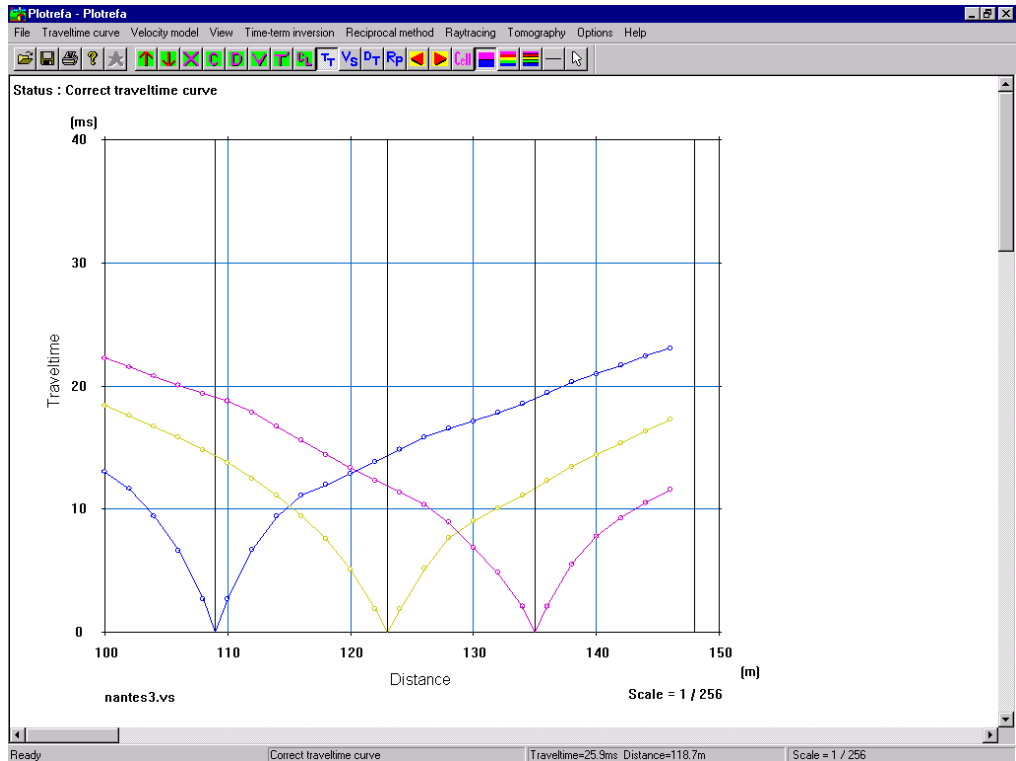

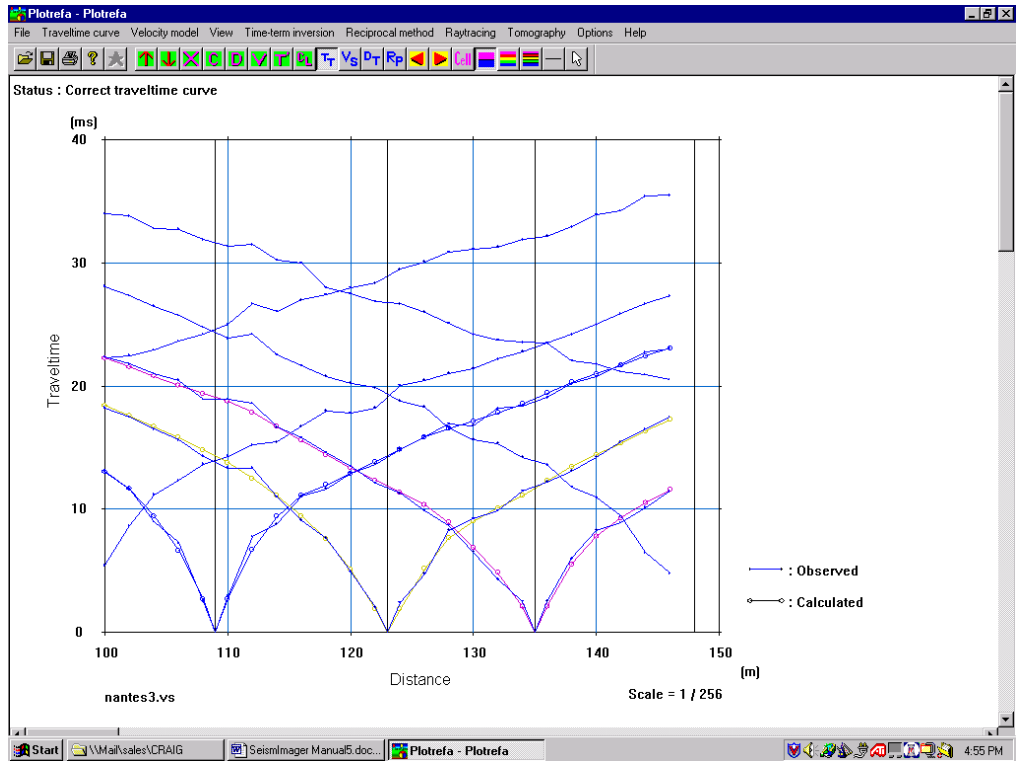

4.2.12 Common Source <-> Common Receiver

It is sometimes useful to organize your traveltine data in a common receiver gather rather than a common source gather. A typical common source gather is displayed below:

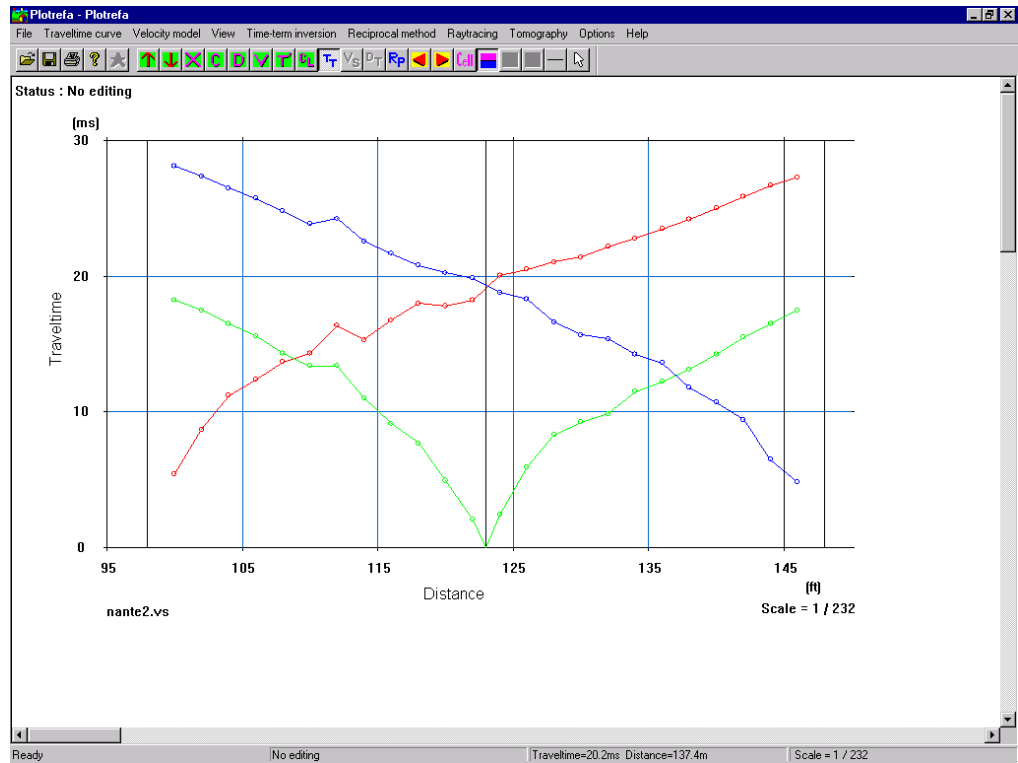

To convert this to a common receiver gather, click on “Common source <-> common receiver”:

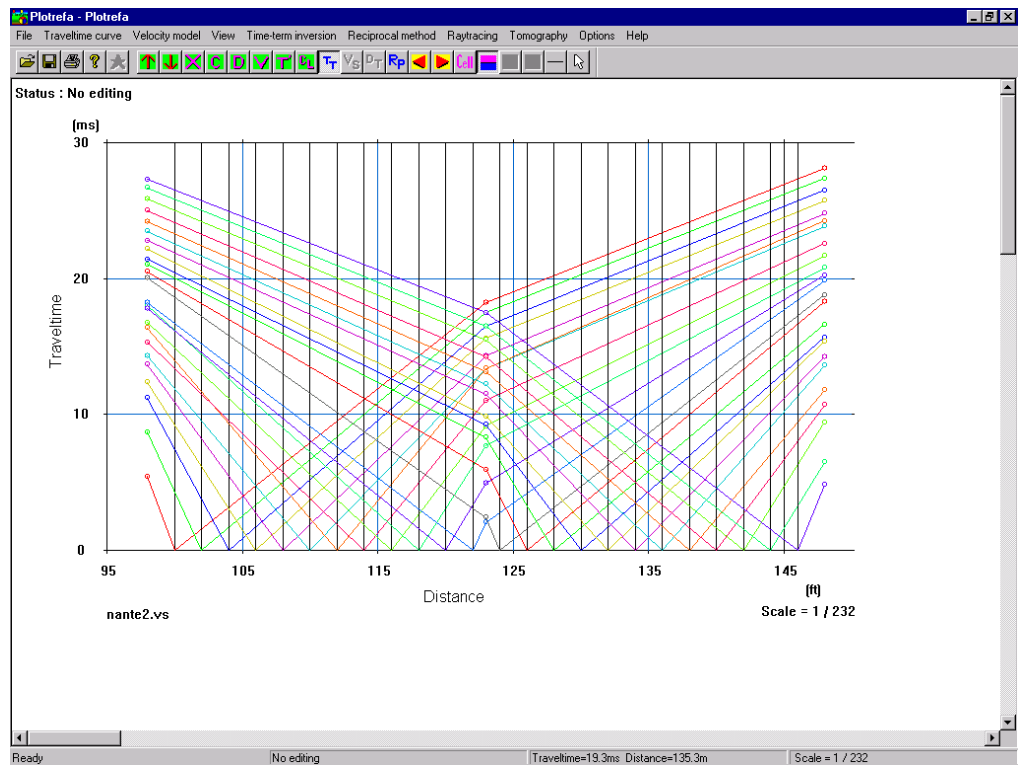

4.2.13 Reverse Survey Line

To reverse the survey line, click on the “Reverse survey line” toggle:

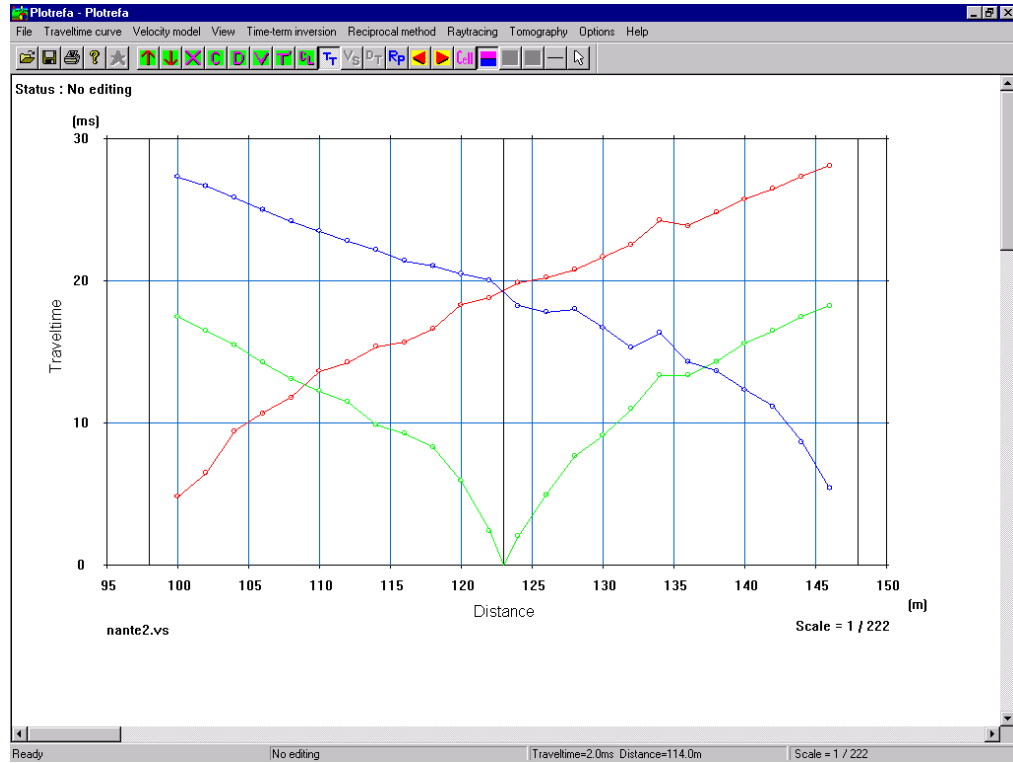

4.3 *Velocity Model Menu*

Click on “Velocity model” to reveal the **Velocity Model** menu:

The **Velocity Model** menu allows you to edit a velocity model and control its appearance. A velocity model can be generated synthetically with the modeling module (discussed in [Section 4.3.23](#)), or it may be calculated from seismic data. A velocity model generated from the data set above will be used for purposes of illustrating the features of this menu.

4.3.1 Define Bottom Layer

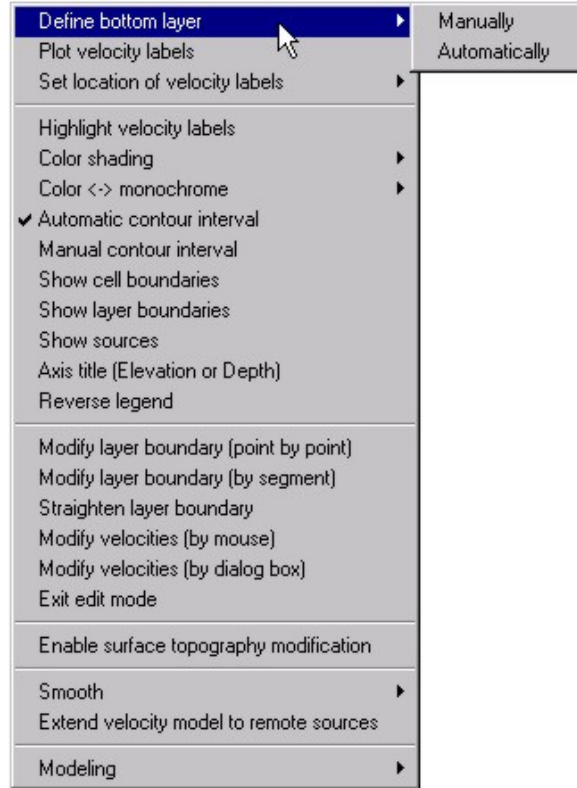

The program automatically assigns a thickness to the bottom layer of an interpreted velocity model. But in a refraction survey, there is insufficient information to actually determine the thickness; it is therefore assigned arbitrarily. However, by drawing the bottom layer with a certain thickness, it can give the impression that this thickness is known. It is therefore sometimes desirable to manually define the base of the bottom layer.

One way to deal with this is to determine the *maximum* thickness of the bottom layer. You can estimate this by assuming a maximum velocity for the layer below it, and using a crossover distance equivalent to the greatest shot-geophone distance in your survey (i.e., you just missed seeing the next layer). Then compute the maximum depth from

$$depth = x_{cross} / 2 \sqrt{(v_{n+1} - v_n) / (v_{n+1} + v_n)},$$

where x_{cross} is the assumed crossover distance, V_n is the velocity of the bottom layer, and V_{n+1} is the assumed maximum velocity.

Once you have computed a maximum depth, you may modify the base layer to reflect this. In the velocity model below, the assumed maximum thickness has been drawn on the model (red line).

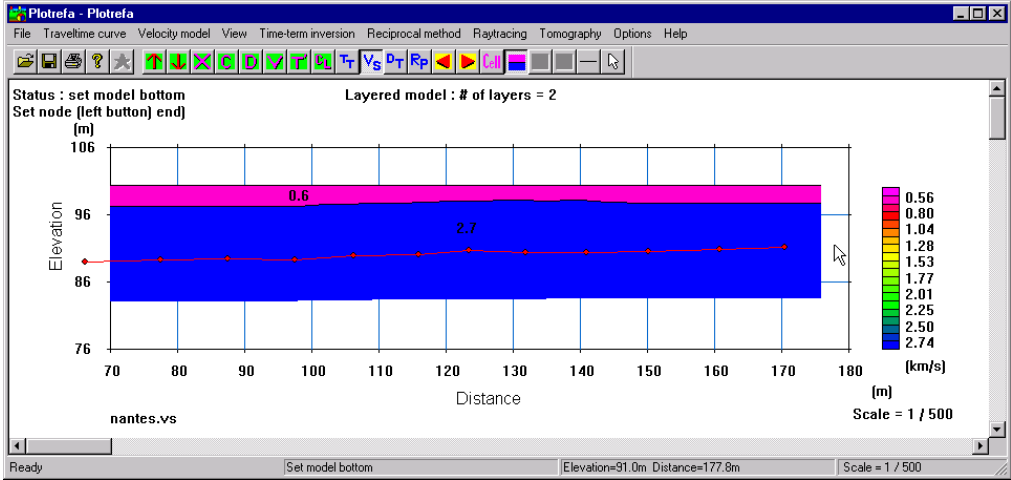

This is accomplished by clicking on “manually” in the sub-menu, and then clicking at various points along the line with the mouse. You must start outside the left edge of the velocity model, as shown above. To complete the process, click outside the right edge of the velocity model (see cursor above):

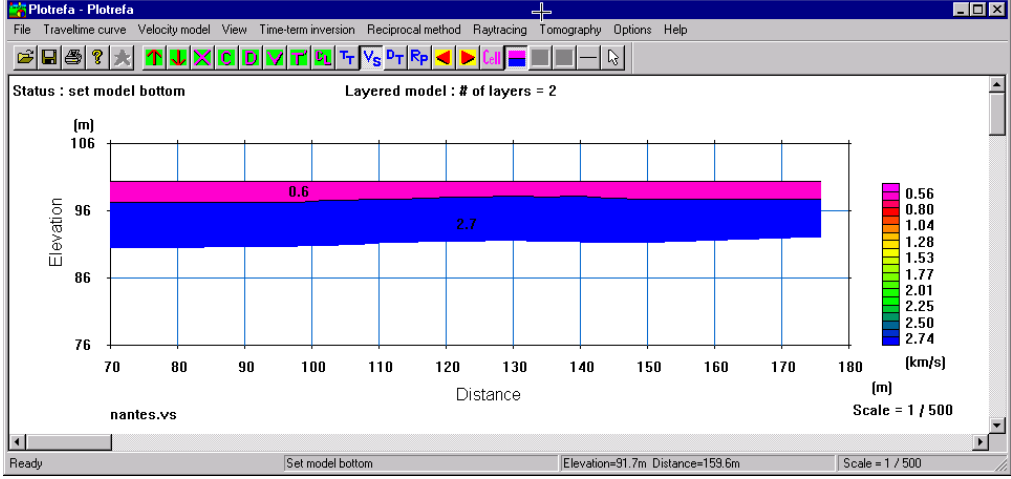

To revert to the automatic thickness, simply click on “automatically”.

4.3.2 Plot Velocity Labels [

You may choose whether or not to show velocity labels in the model. Below is a model with velocity labels shown, followed by the same model without the velocity labels shown:

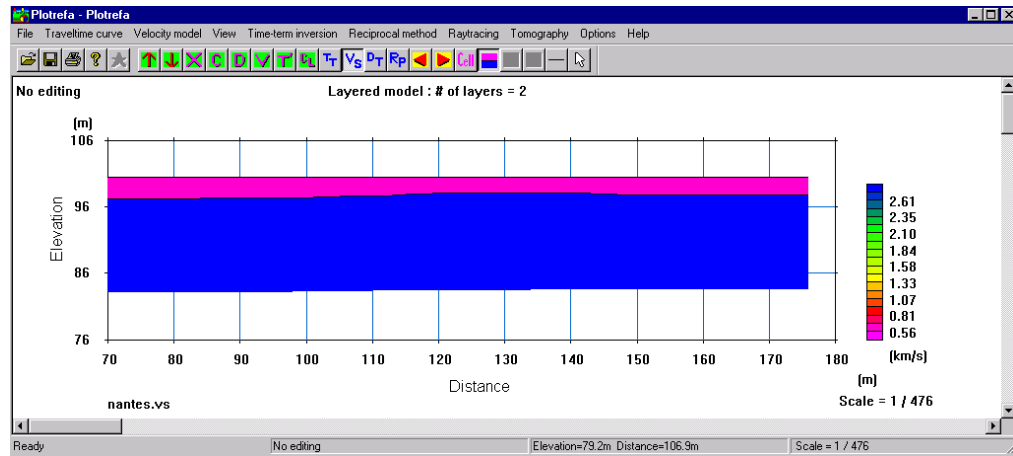
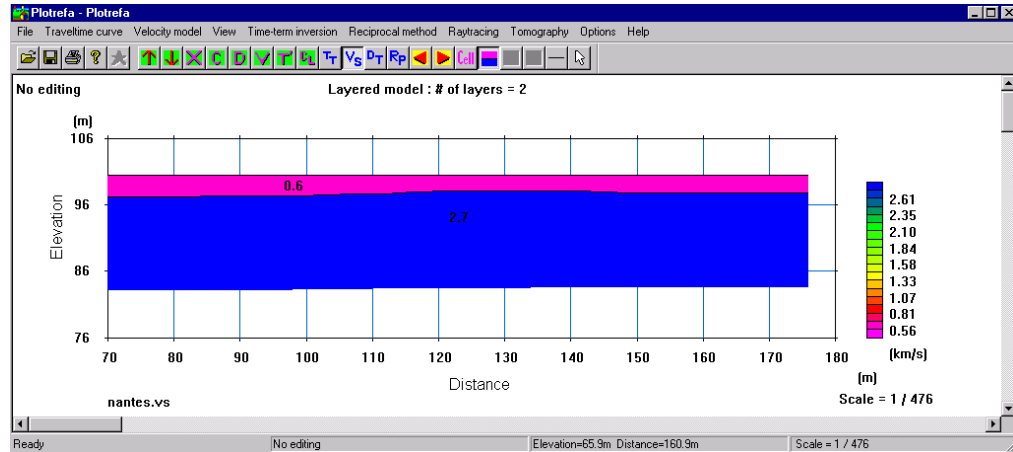

4.3.3 Set Location of Velocity Labels

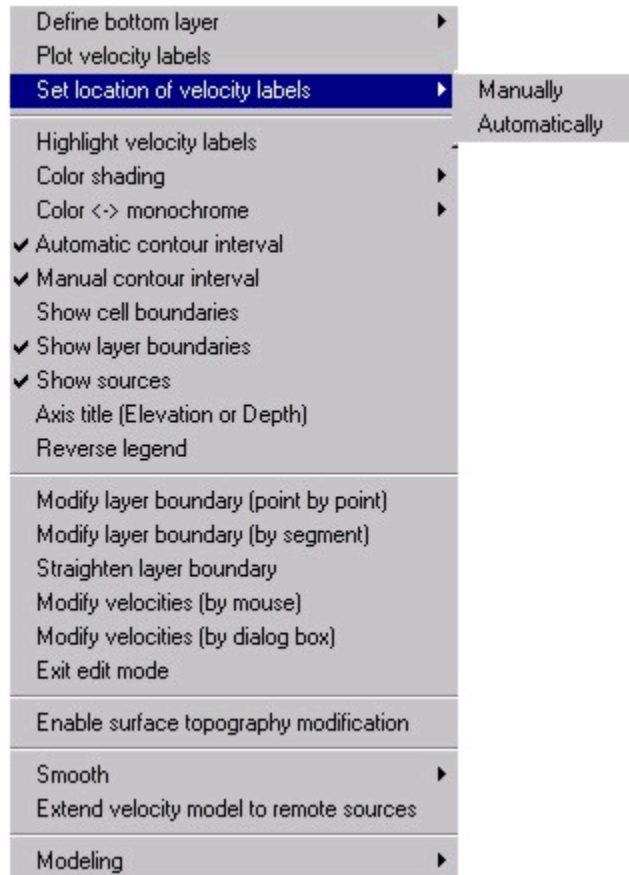

The location of velocity may be set manually, or the program can set it automatically. To set it manually, simply click and hold on the center of the label, drag it to the desired location, and release:

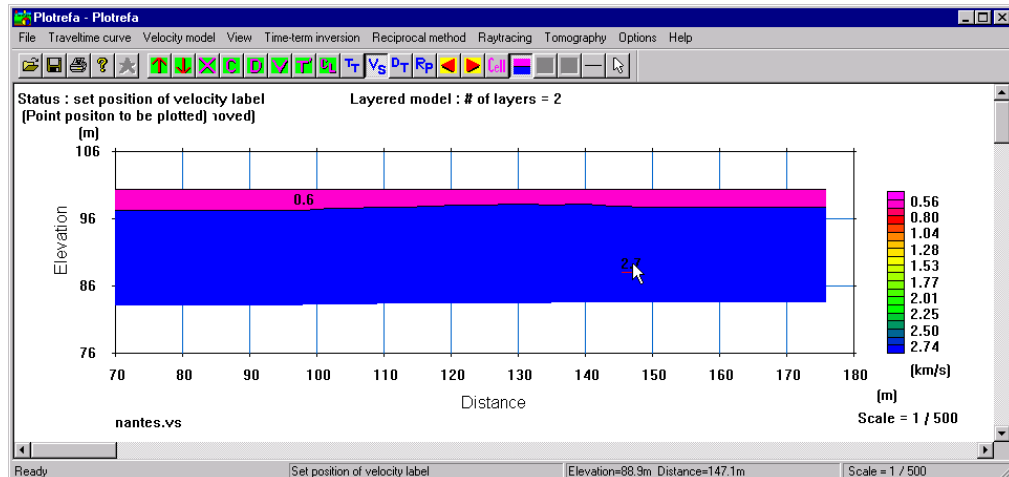

Note: A small red line will appear under the label to indicate that you have actually grabbed it with the mouse.

4.3.4 Highlight Velocity Labels [

You may highlight the velocity labels to make them more visible. Simply choose “Highlight velocity labels” in the menu. Below is the same velocity model with the labels highlighted:

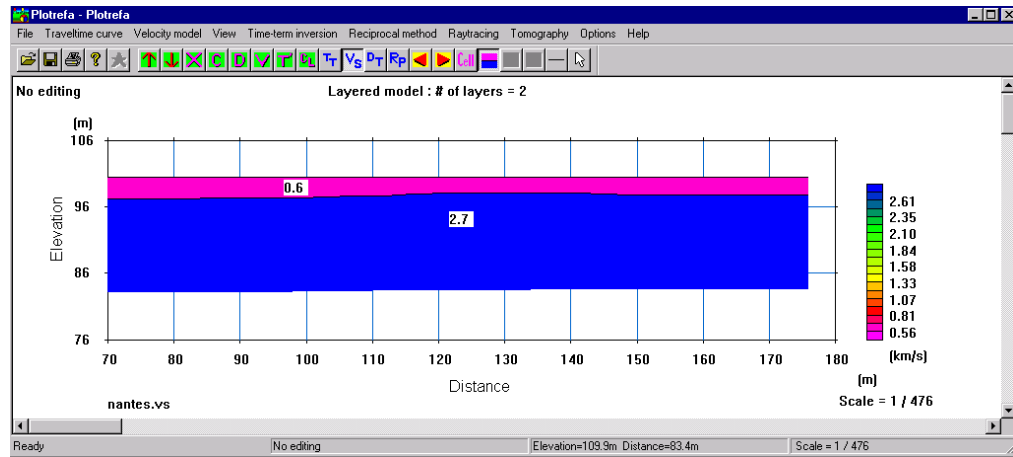

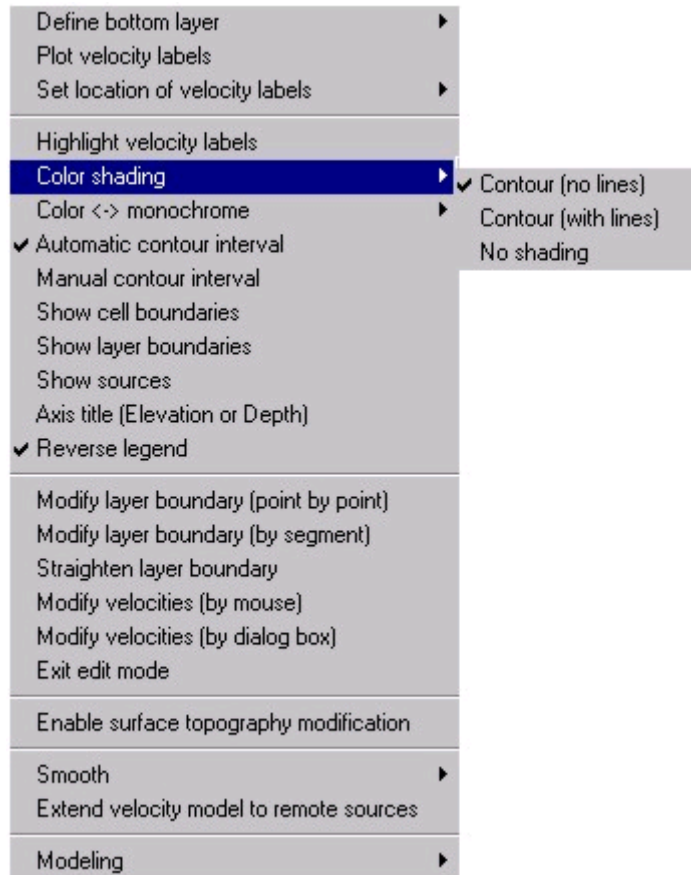

4.3.5 Color Shading [



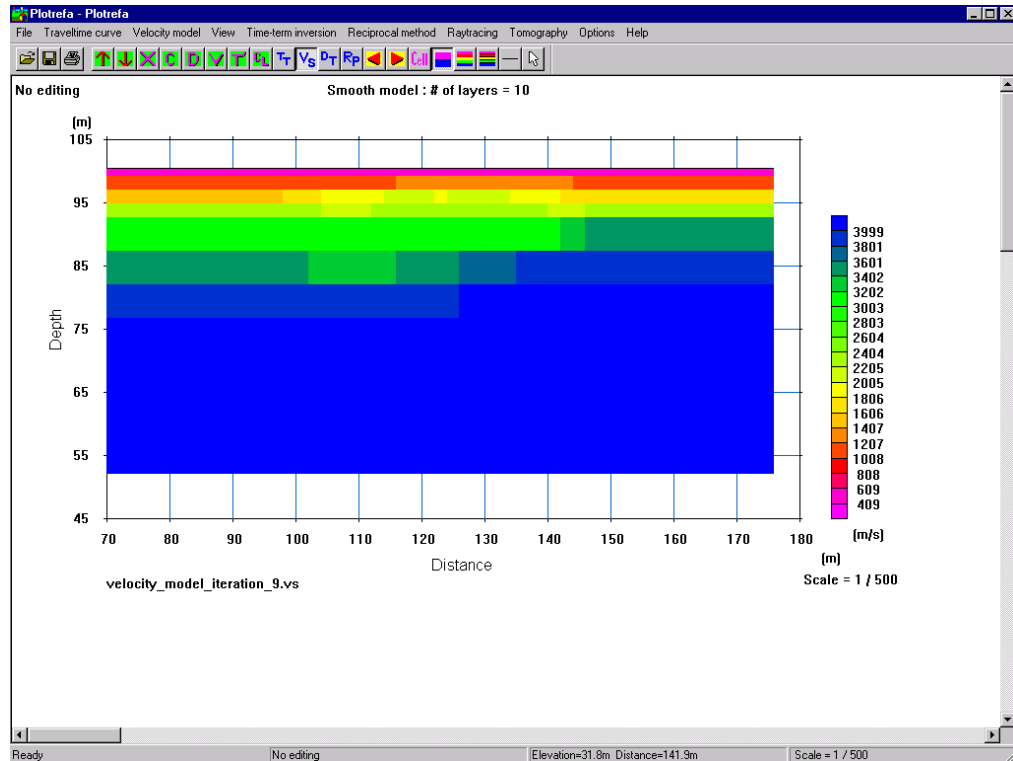

If you have done a tomographic inversion, your velocity model will not consist of discrete layers of constant velocity like those discussed so far, but will instead resemble that shown below:

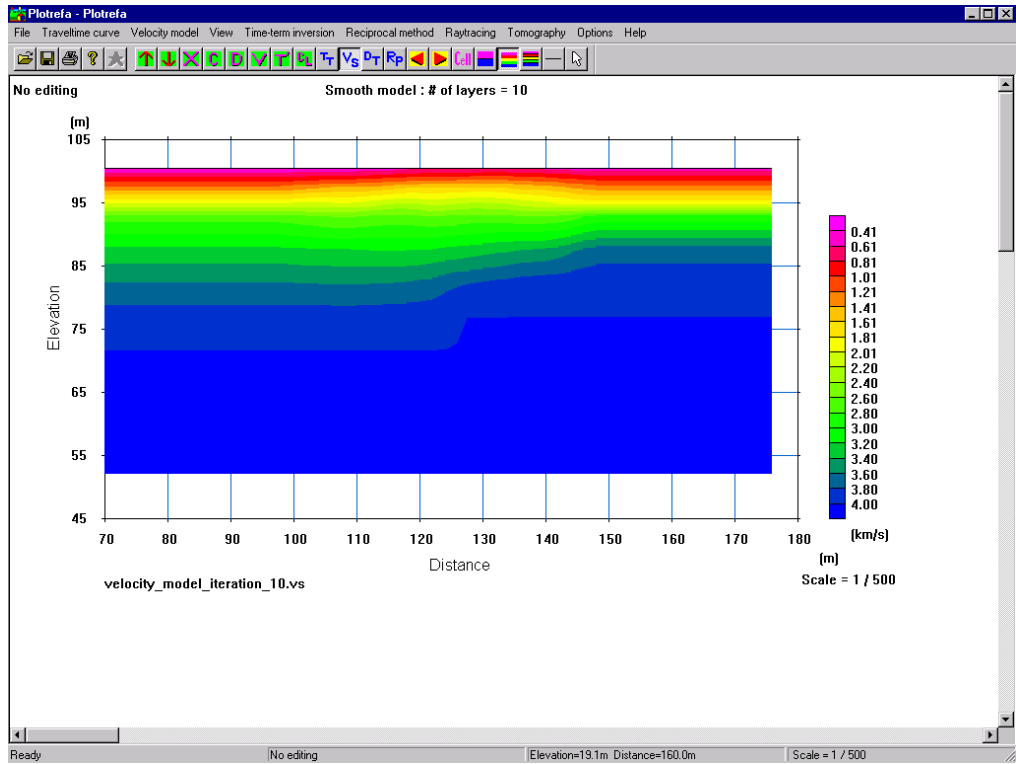

In a tomographic inversion, the velocity model is divided into velocity “cells”. In the above model, the velocity for each cell is displayed. This is the default setting for tomographic inversions, and is enabled by pressing the  tool button.

To create a more aesthetically-pleasing velocity model, you may wish to contour the velocities. Choose “Contour (no lines)”, or press the  tool button to contour the data:



If you would like to include the actual contour lines, choose “Contour (with lines)”, or press the  tool button:

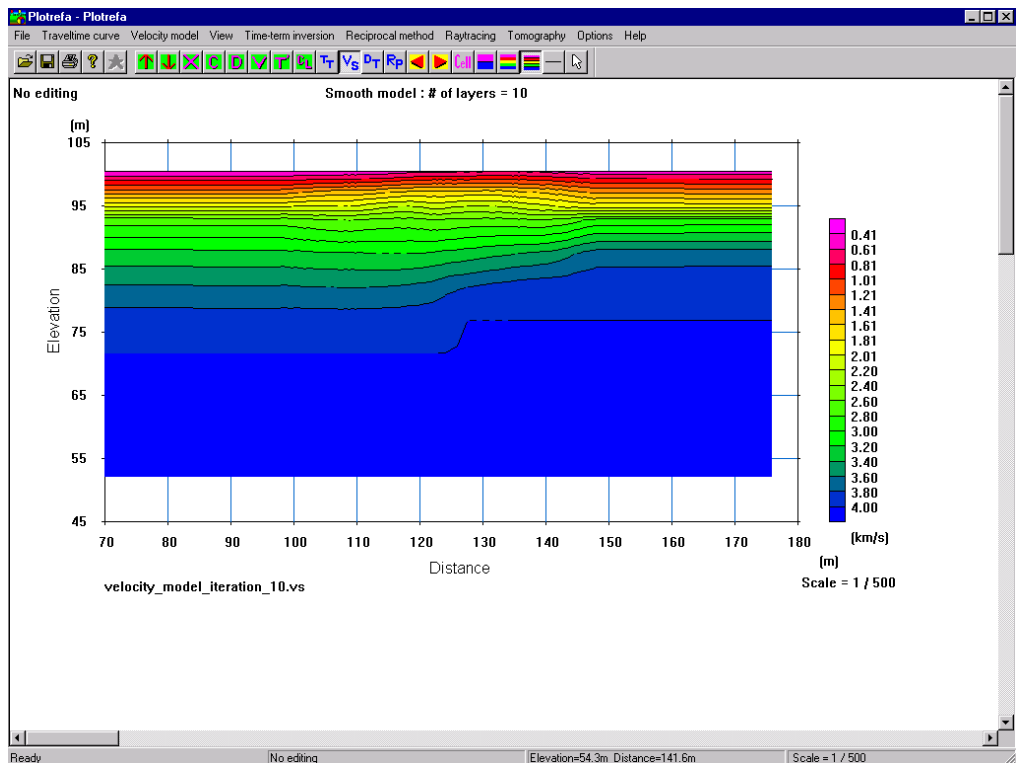

If you have a layered model (defined as seven layers or less), like the one below,

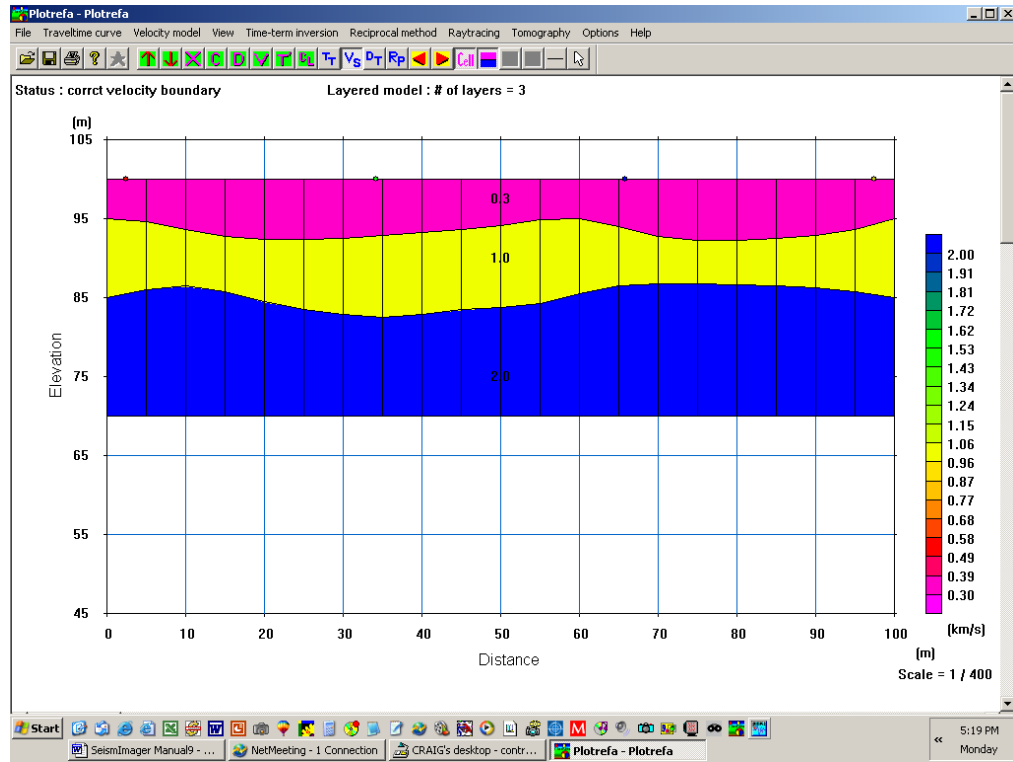

and you would like to remove the colors, choose “No shading”, or press the button:

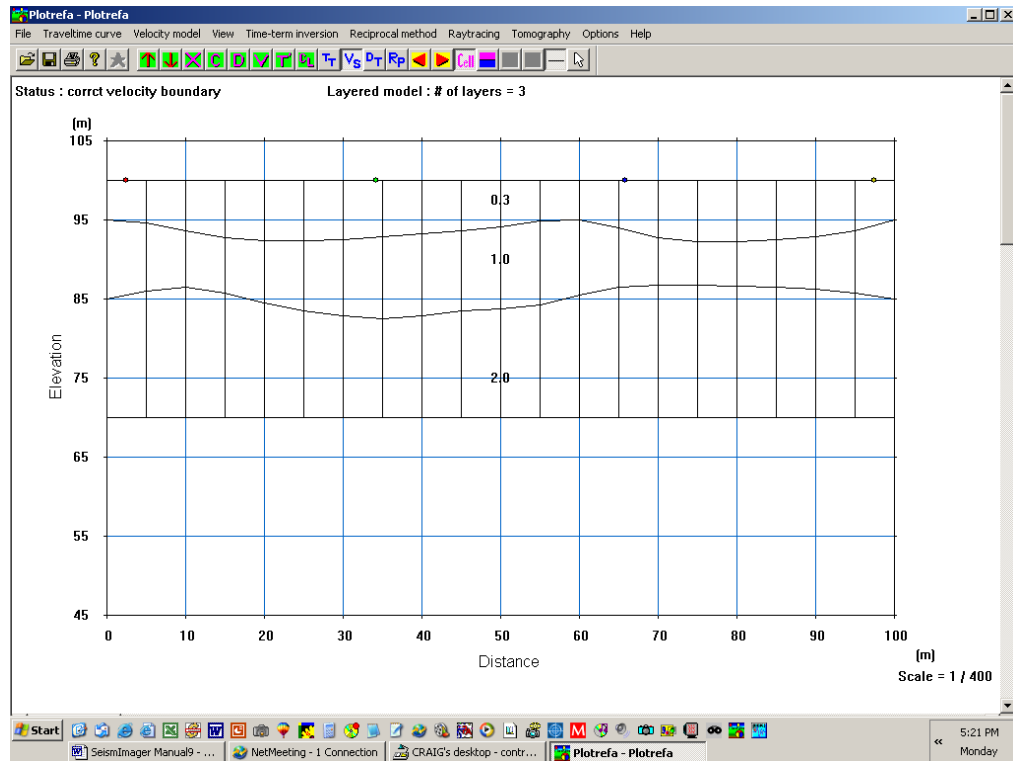

To turn color back on, press the tool button.

Note: Only layered models can be displayed in this manner; tomographic models cannot.

4.3.6 Color <-> Monochrome [

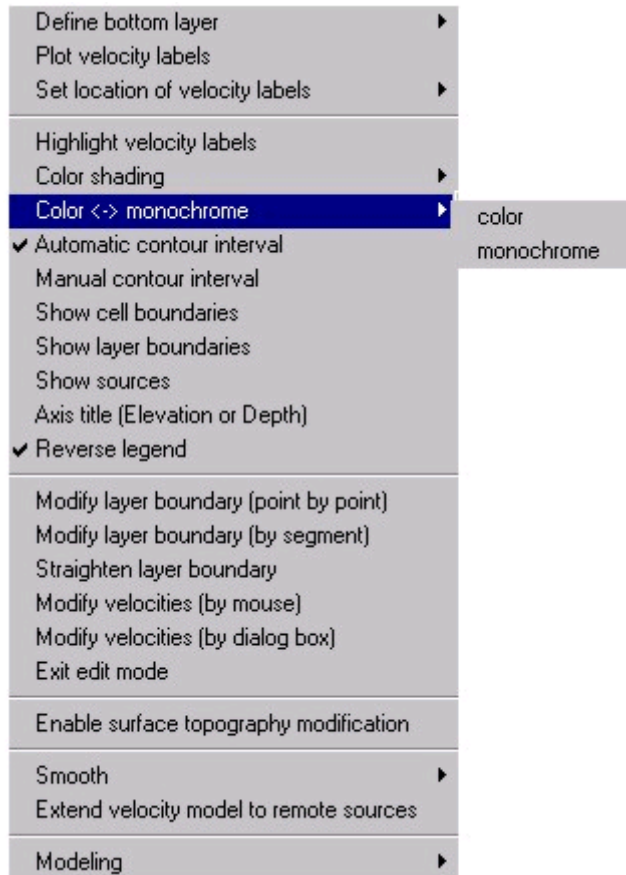

If you wish show your velocity model in shades of gray, choose “monochrome”:

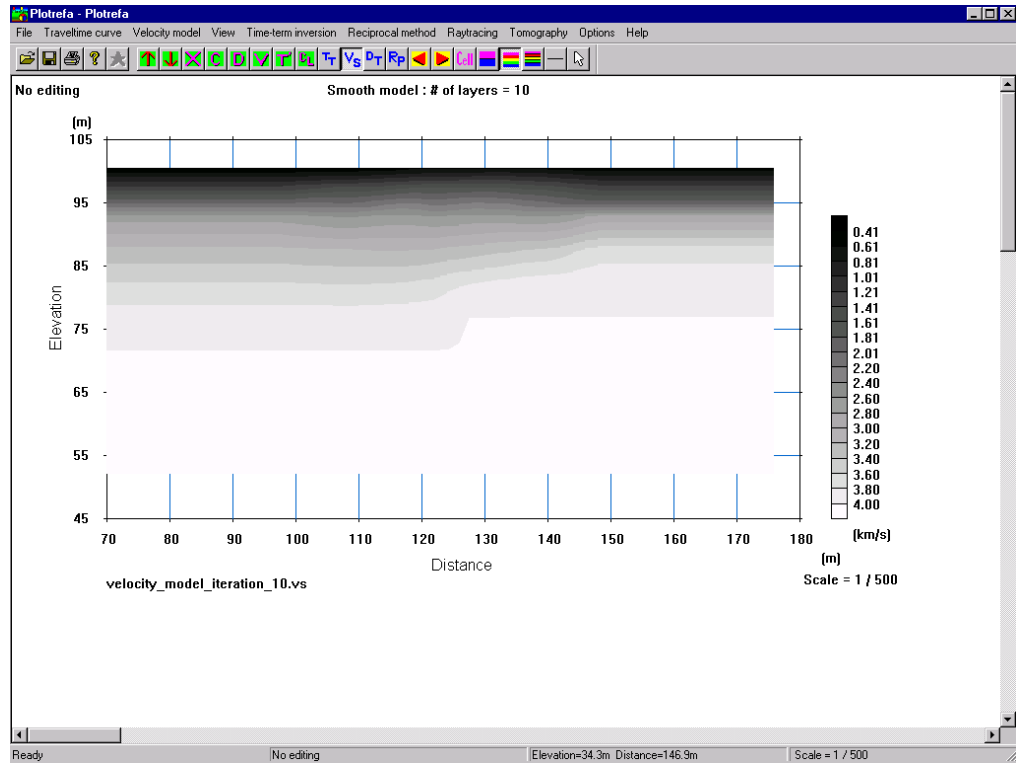

To change it back to a color display, choose “color”.

4.3.7 Automatic Contour Interval [

If you want the contour interval to be chosen by the program automatically, click on “Automatic contour interval”.

4.3.8 Manual Contour Interval

If you would like to set the contour interval manually, choose “Manual contour interval” to reveal the following dialog box:

Set the desired contouring parameters, and press **OK**.

4.3.9 Show Cell Boundaries [

If you would like to display the cell boundaries, click on “Show cell boundaries”, or press the  tool button:

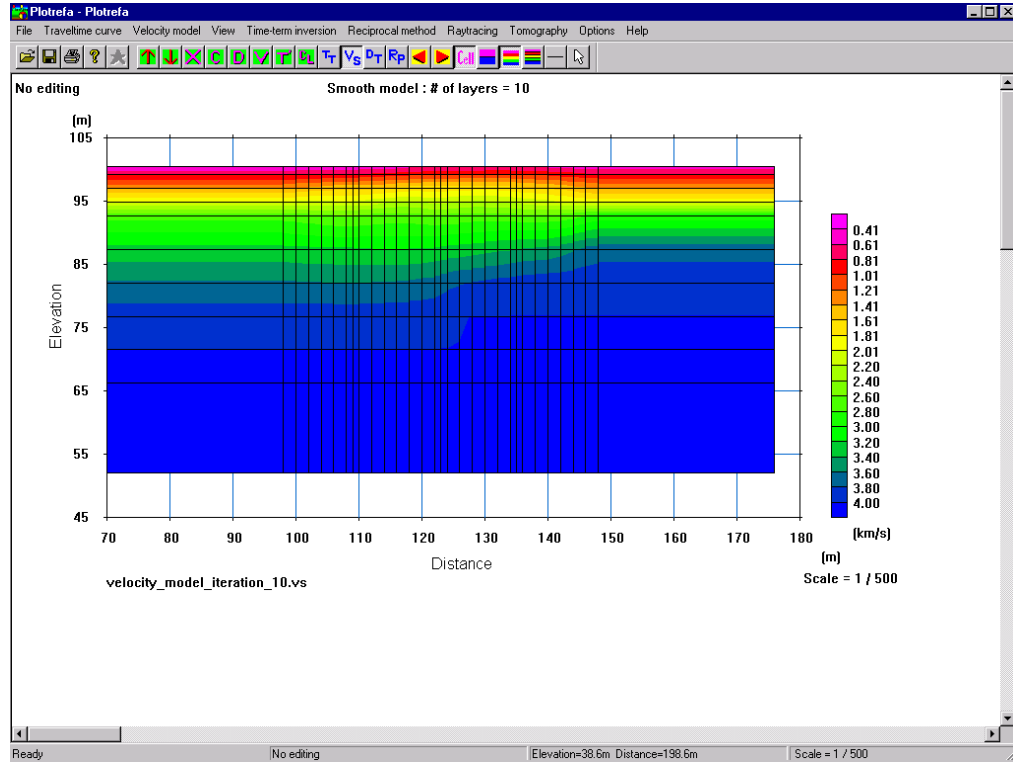

4.3.10 Show Layer Boundaries [

If you would like to display only the layer boundaries, disable the cell display and choose “Show layer boundaries”:

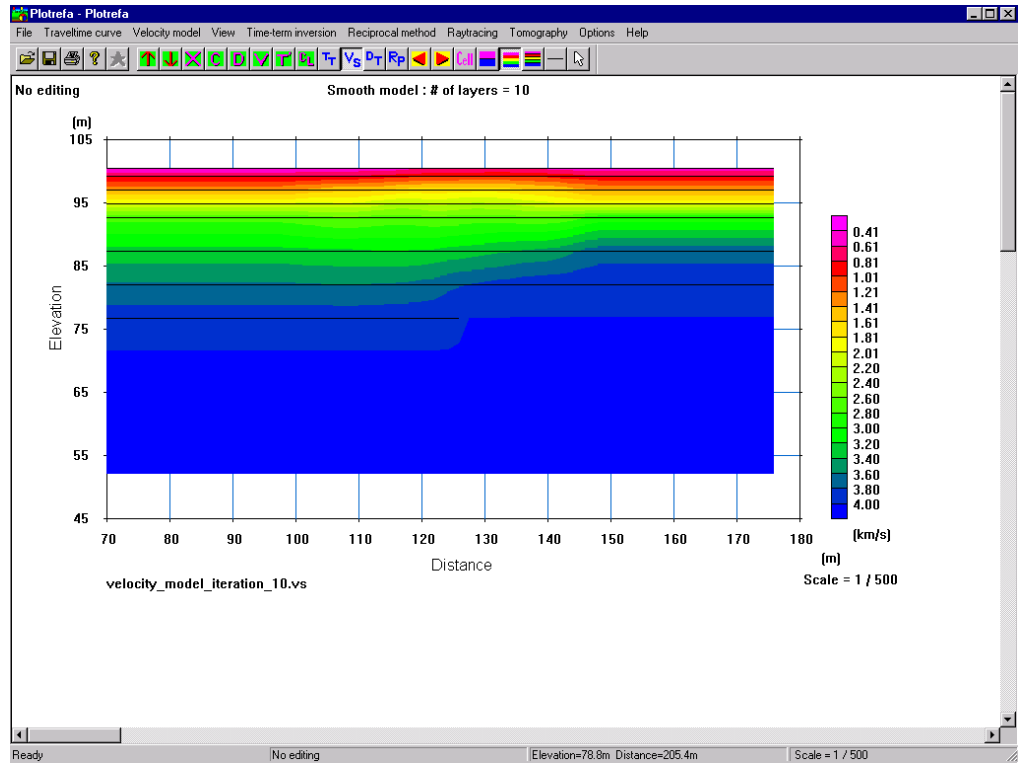

4.3.11 Show Sources [

If you wish to show where the sources are located, click on “Show sources”:

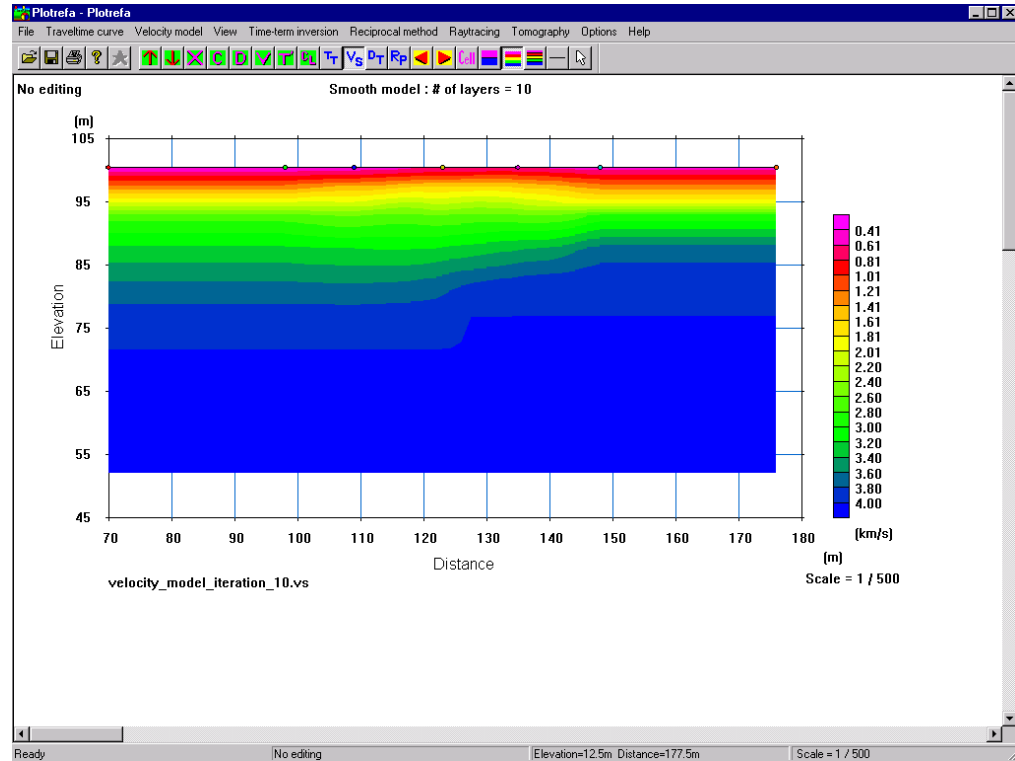

4.3.12 Axis Title (Elevation or Depth)

If you have surveyed the actual elevations along the survey lines, you may label the vertical axis as an “Elevation” axis. Otherwise, you may label it a “Depth” axis. Simply click on “Axis Title (Elevation or Depth)” to toggle between the two options.

4.3.13 Reverse Legend [

You may reverse the legend to put high velocities at the top and low velocities at the bottom, or vice versa. Simply click on “Reverse legend” to toggle between the two:

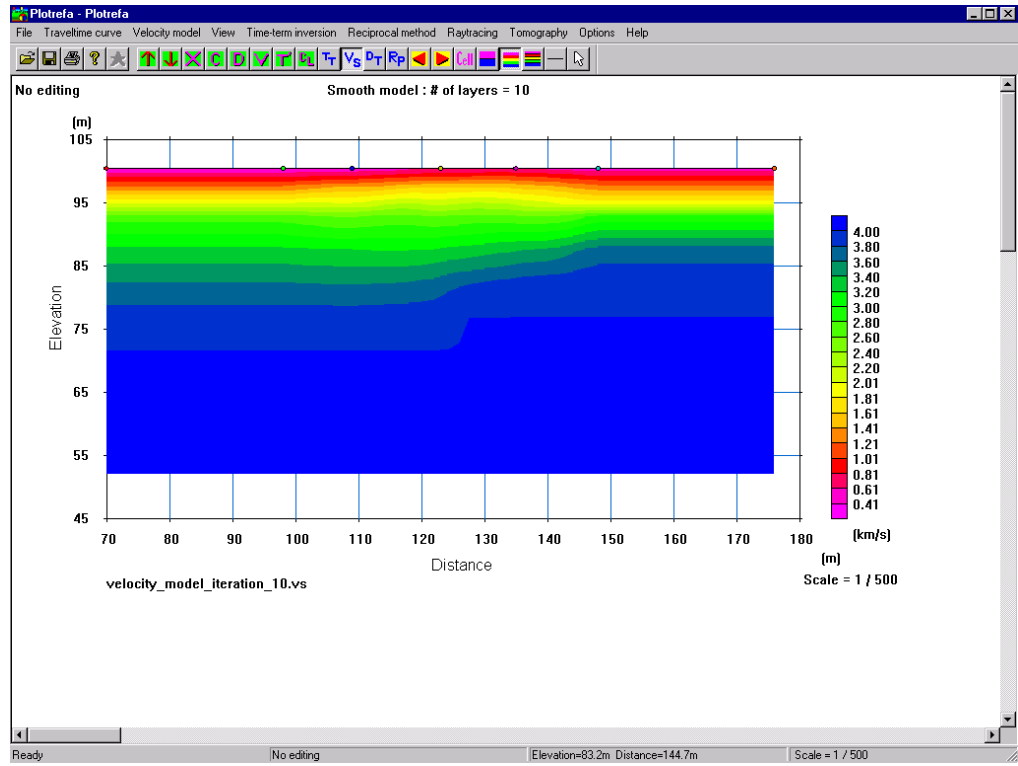

4.3.14 Modify Layer Boundary (Point by Point)

You may modify the velocities and geometry of your velocity model. This is most useful for doing forward modeling (discussed later).

Below is a synthetic velocity model:

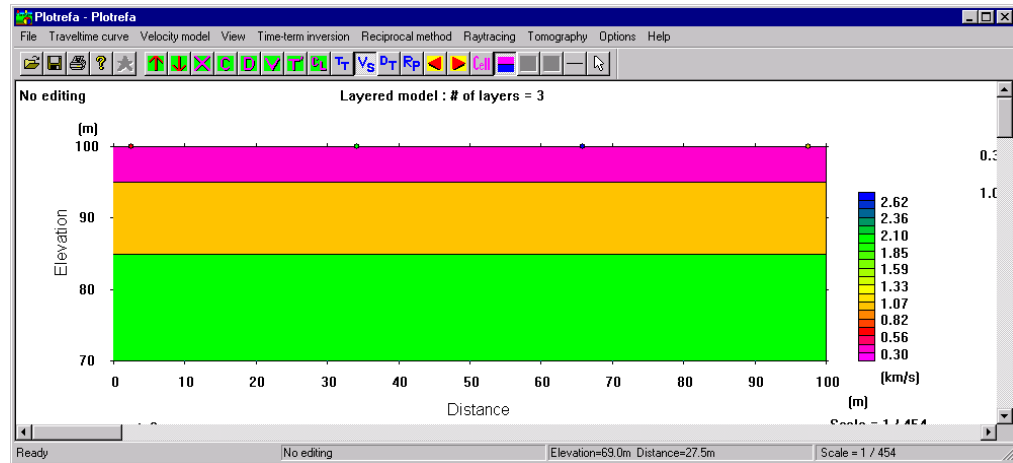

To change the geometry of the velocity boundaries on a point-by-point basis, click on “Modify layer boundary (point by point)”, or press the  tool button. The individual velocity cells will be displayed. You may change the depth of any layer by clicking on a cell intersection and dragging the red dot to the desired depth:

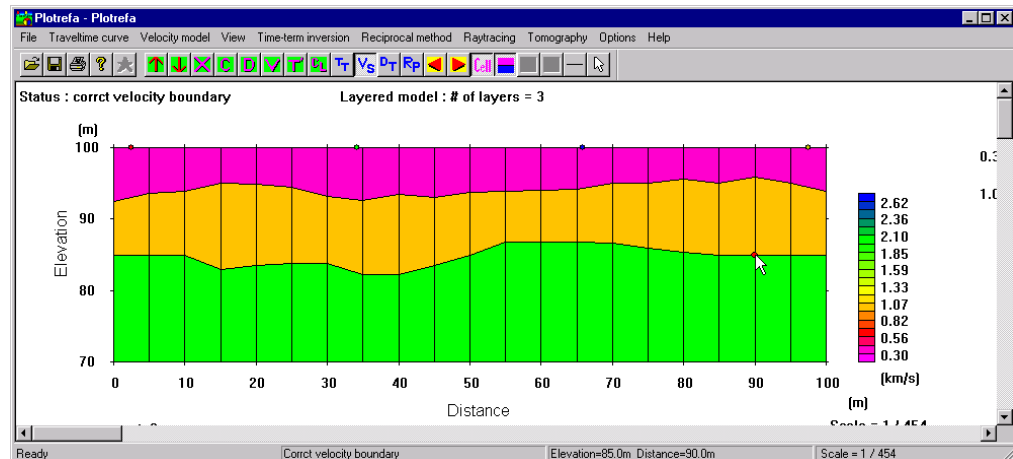

4.3.15 Modify Layer Boundary (by Segment)

In addition to moving individual points, you can also grab an entire segment of a boundary and move it. Choose “Modify layer boundary (by segment)”. Click on one end of the segment you wish to move. A red dot will be displayed. Now, click on the other end:

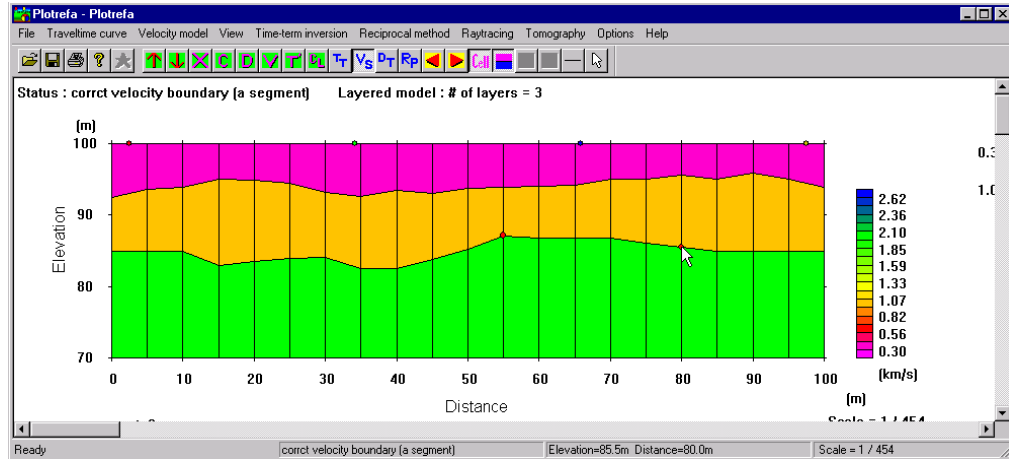

Drag the second red dot to the desired depth:

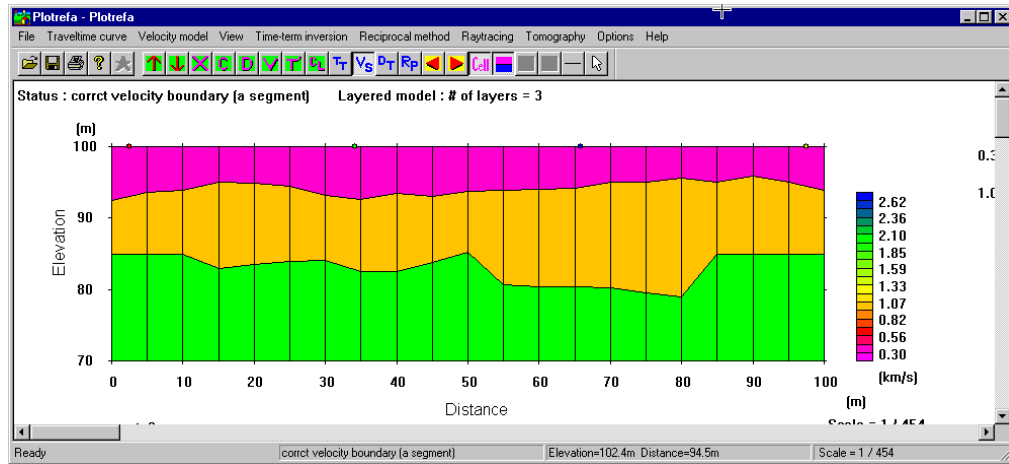

4.3.16 Straighten Layer Boundary

If you wish to straighten the layer boundary between two points, choose “Straighten layer boundary”. Click on the first end of the segment you wish to straighten:

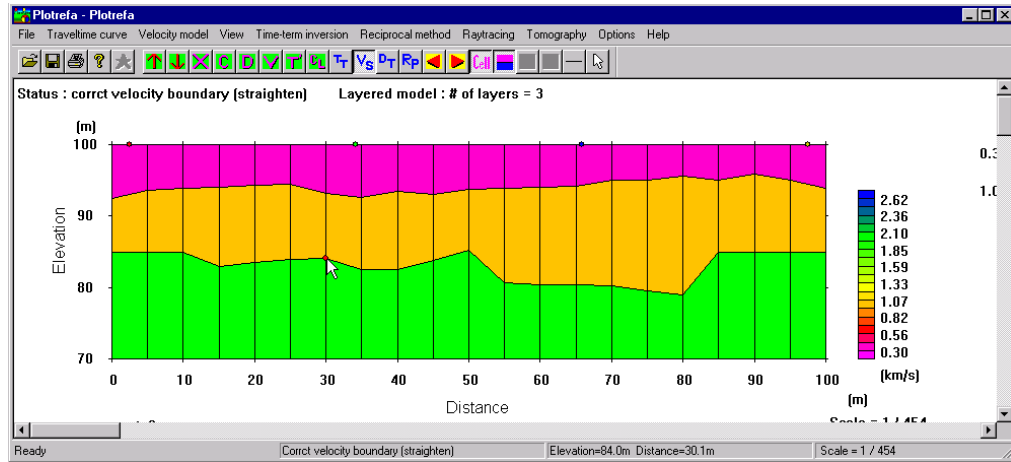

Then click on the other end of the segment:

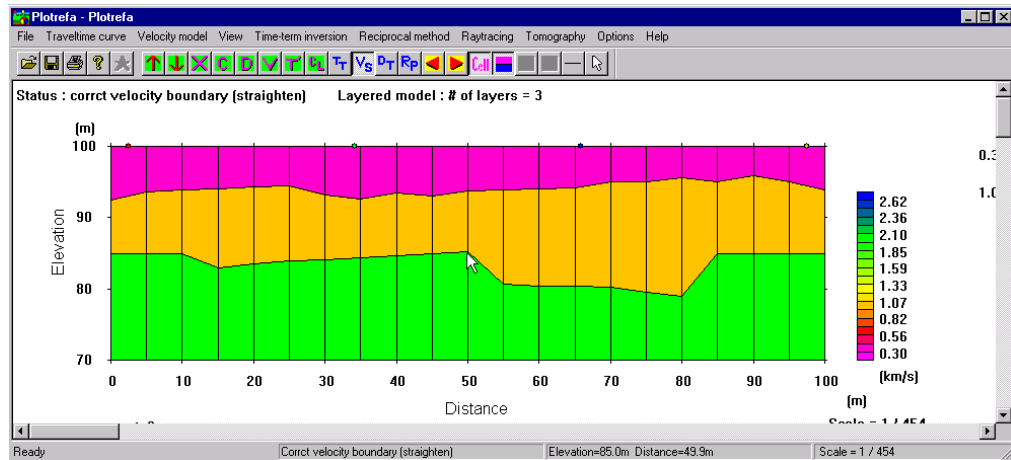

The layer segment will be a straight line between the two points.

4.3.17 Modify Velocities (by Mouse)

In addition to editing the geometry of the model, you may also edit the velocities. You can do this via mouse or dialog box. To edit velocities using your mouse, choose “Modify velocities (by mouse)”. The following dialog box will be revealed:

Enter the desired velocity, and press **OK**.

Now, click on the cells or click and drag your mouse over the region you wish to alter the velocity:

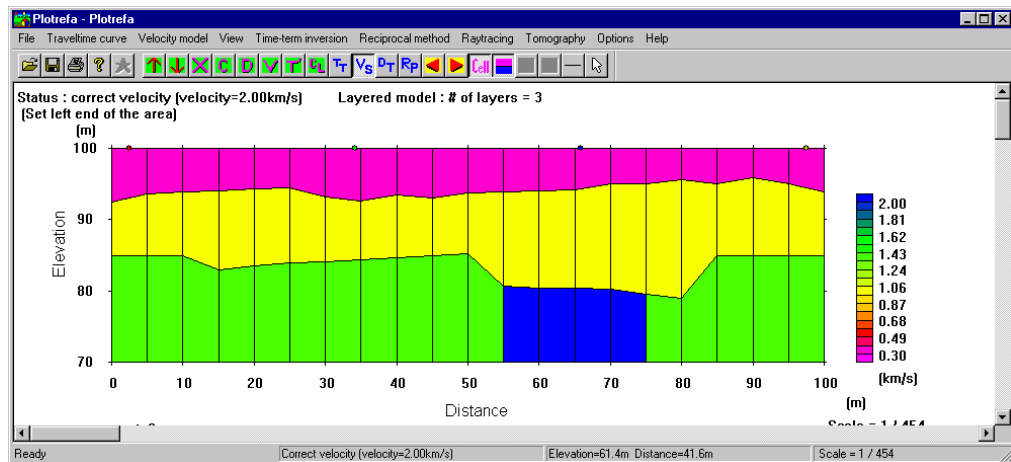

4.3.18 Modify Velocities (by Dialog Box)

To accomplish the above via dialog box, choose “Modify velocities (by dialog box)”. The following dialog box will appear (the values have already been filled in for this demonstration):

Indicate the layer, distance range, and new velocity, and press **OK**:

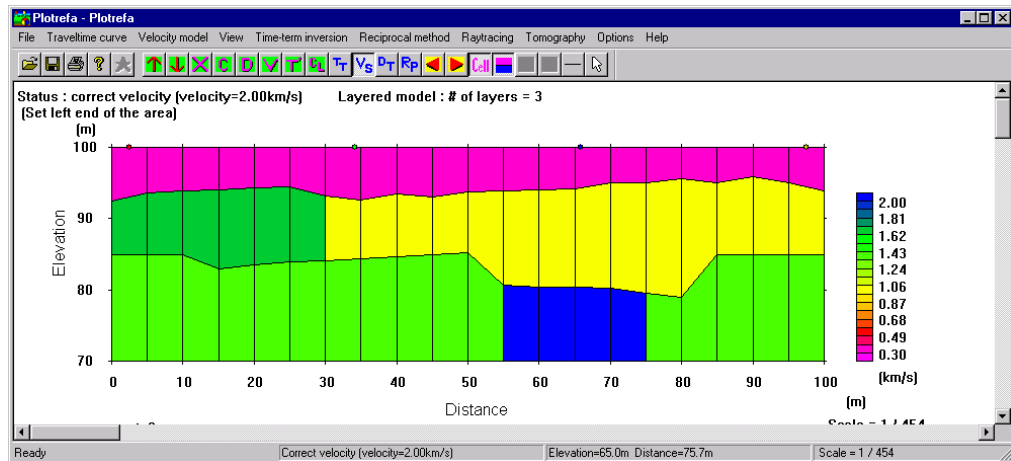

The velocity structure will be modified accordingly.

4.3.19 Exit Edit Mode

When modifying the geometry or velocities of the velocity model, you are in a “Edit” mode. To exit this mode, choose “Exit edit mode”, or just press the tool button.

In a manner similar to Pickwin ([Section 4.2.1](#)), when not in edit mode, you can use the mouse to measure vertical distances:

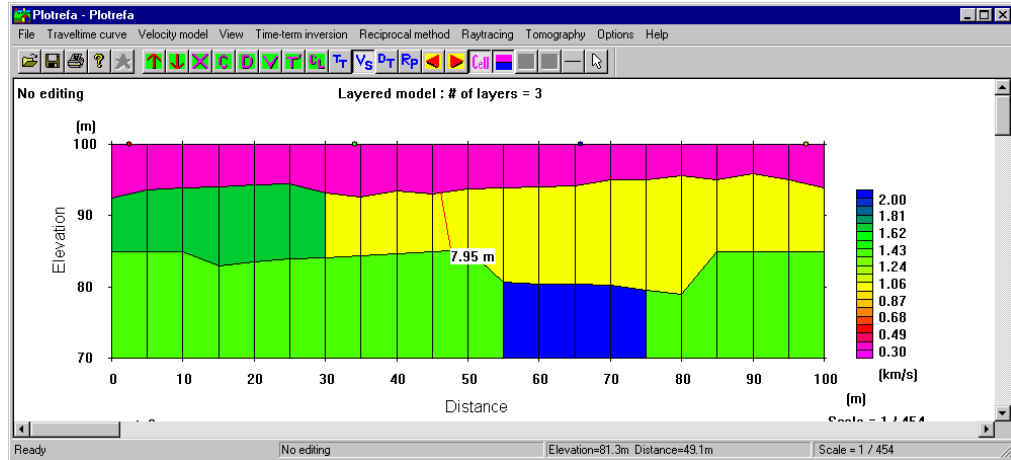

4.3.20 Enable Surface Topography Modification [

Modifying the topography is accomplished in the same manner as modifying velocity boundaries. However, you must enable this capability first. Click on “Enable surface topography modification”, then modify the surface as described in [Sections 4.3.14 – 4.3.16](#).

4.3.21 Smooth

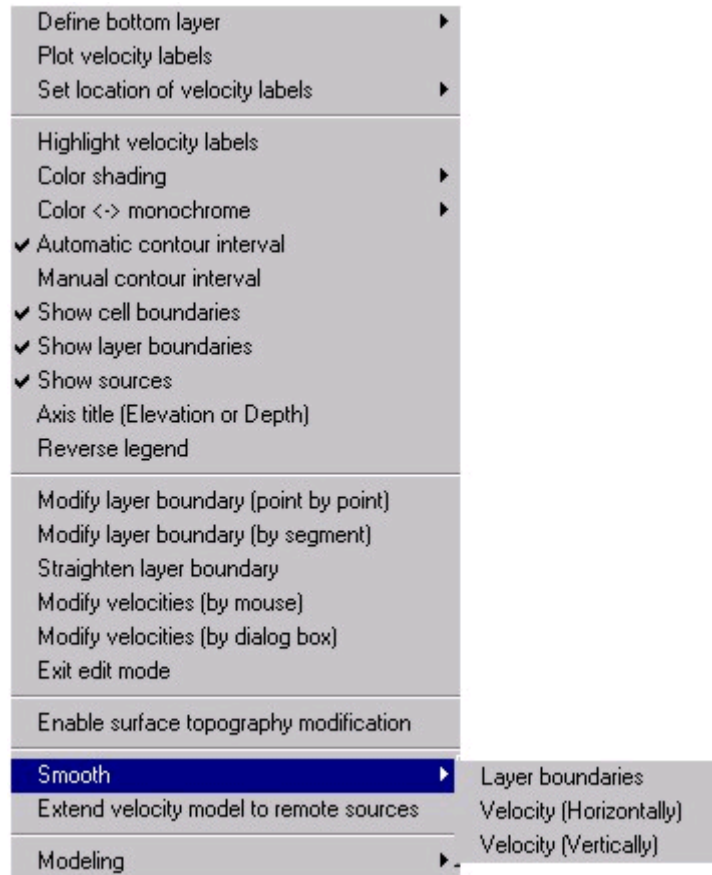

The layer boundaries and velocity transitions can be smoothed. To smooth layer boundaries, choose “Layer boundaries” from the sub-menu:

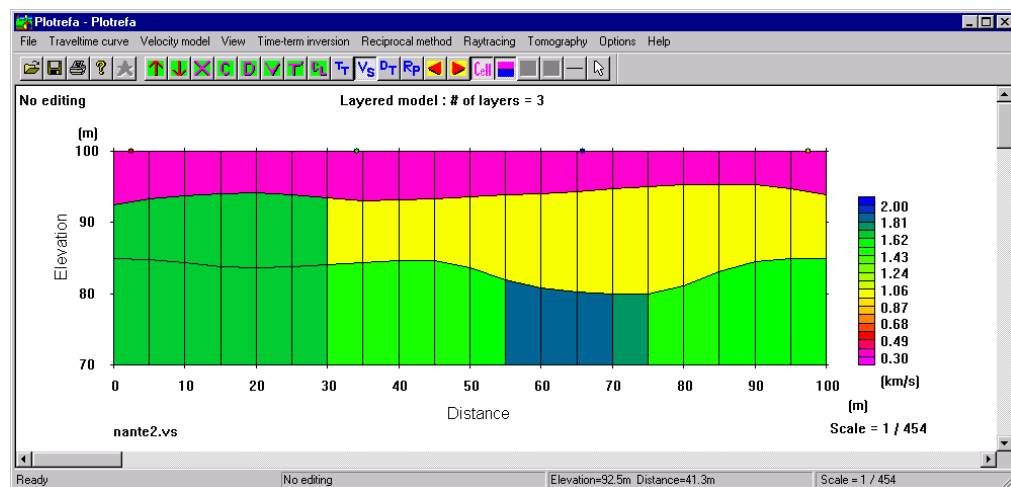

To smooth out horizontal velocity changes, choose “Velocity (horizontally)”:

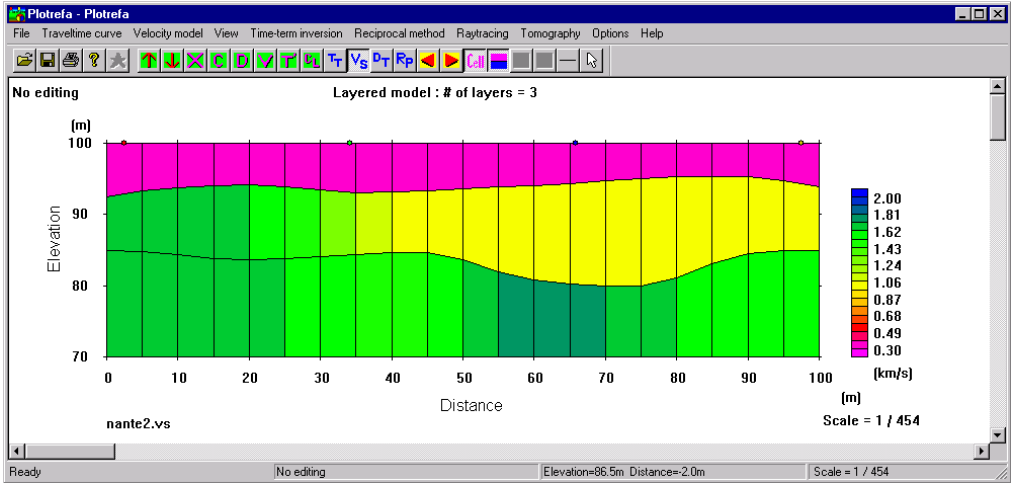

To smooth out vertical velocity changes, choose “Velocity (vertically)”:

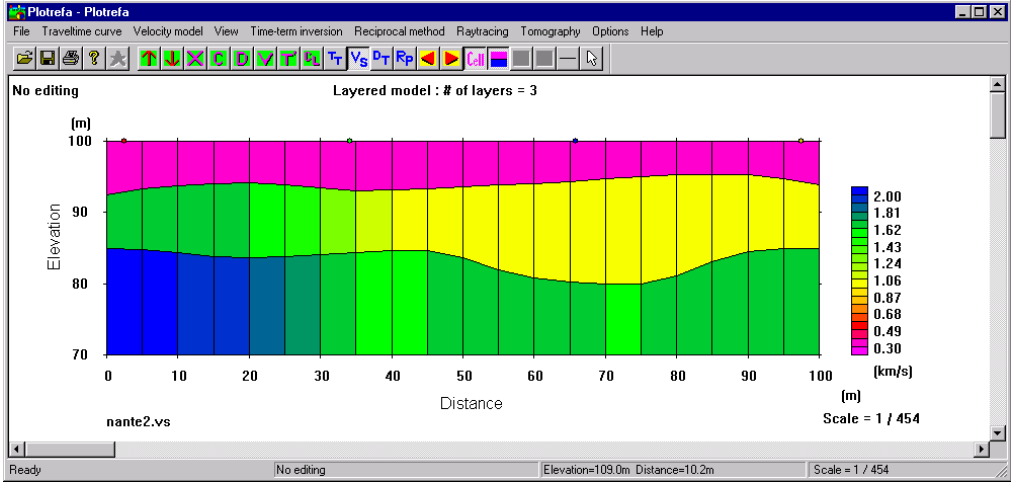

With all three of the above smoothing operations, each time you click, a little more smoothing occurs. For instance, in the above model, the layers were smoothed twice. In the one below, it has been smoothed five times:

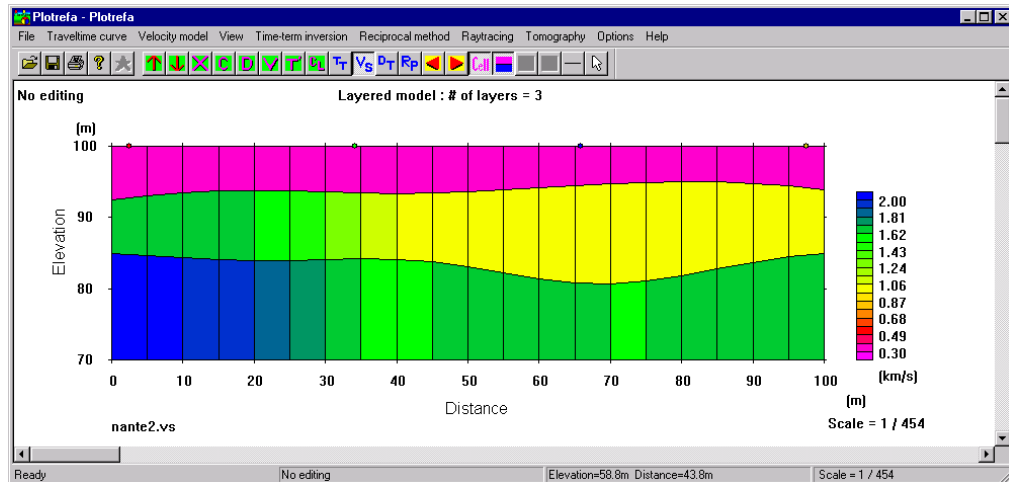

4.3.22 Extend Velocity Model to Remote Sources

When using remote shots, it is sometimes necessary to manually extend the velocity model to include them. If the velocity model is not extended to include the remote shots, the data from those shots cannot be used in the final inversion.

When the topography is flat, the model will automatically extend to the remote sources, and they will be included in the inversion. However, if the topography is not flat, the remote sources will only be included if their elevations are included in the elevation file. Since the elevation of a remote source is not a necessary parameter to record, it is often not measured. If they are not, you will have to extend the model manually. This is best illustrated by example.

Below are the traveltimes data and the corresponding time-term inversion from a site with significant topography. Note that in addition to shots at the ends and within the spread, there are four shots off either end.

Note: SeisImager/2D treats any shot outside of the spread, even the two “end shots” (see below) as remote sources.

The elevation file did not include the actual elevations of the remote shots, and as a result, the data from the remote shots were not included in the time-term inversion.

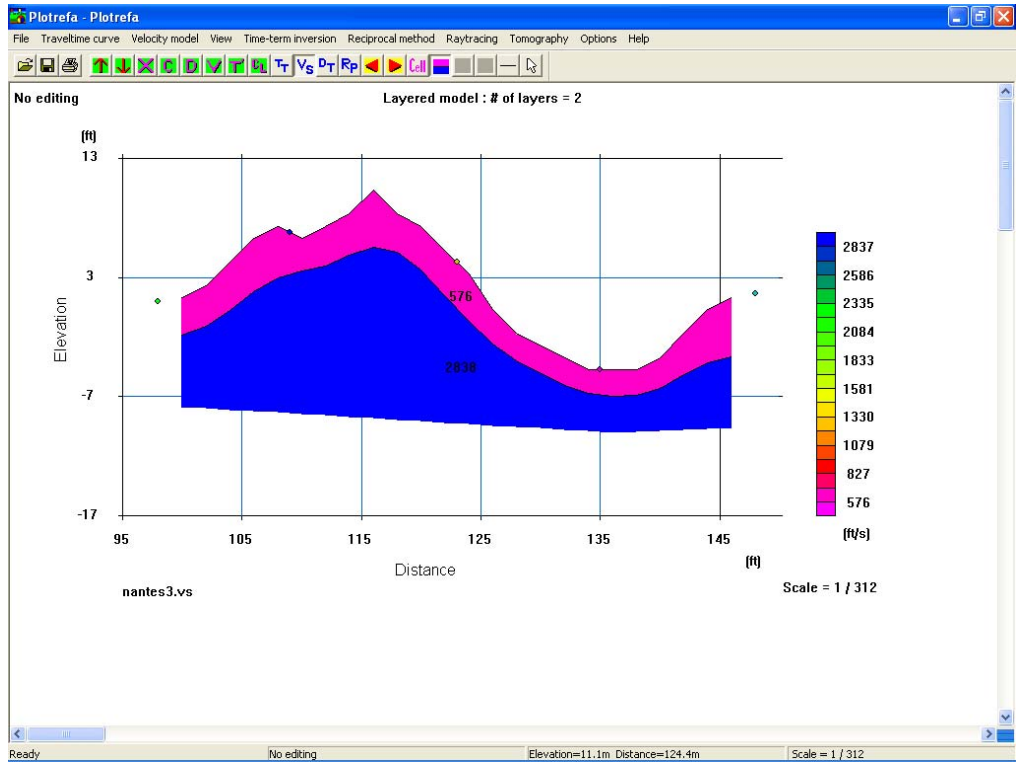
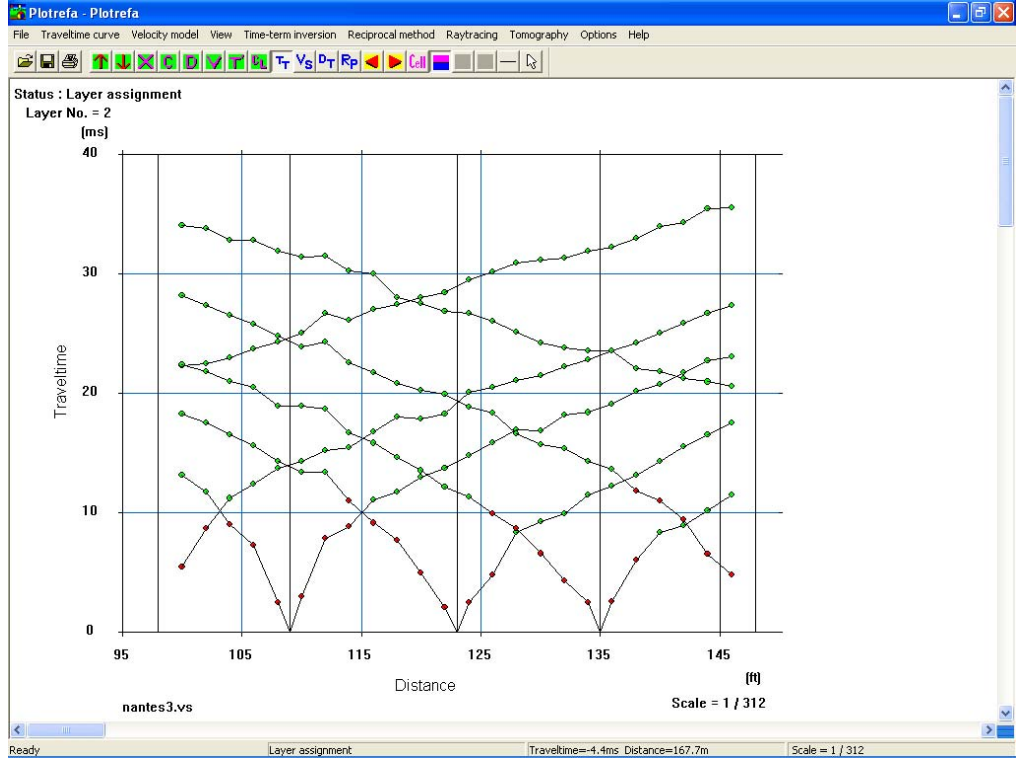

This can be demonstrated by running the ray tracing routine through the above velocity model:

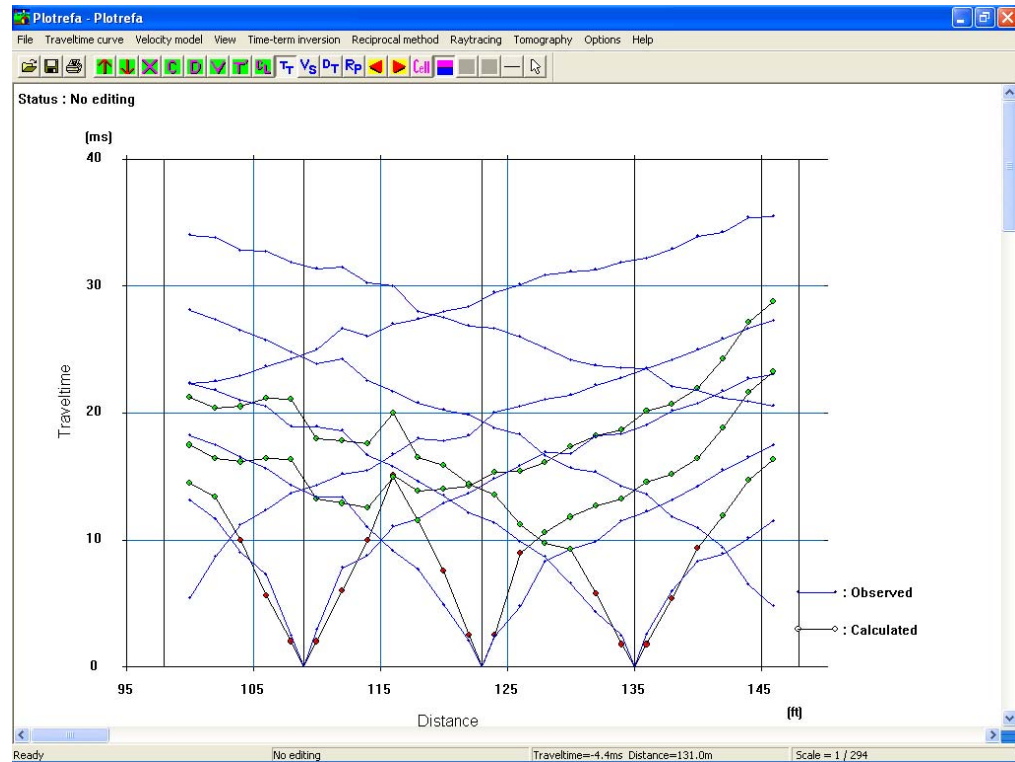

Note that no theoretical traveltimes have not been computed for the remote sources. We must extend the velocity model to include them.

To extend the velocity model, choose “Extend velocity model remote sources” to reveal the following dialog box:

The distance values will default to the locations of the farthest remote shots. The number of cells generally defaulted to zero. Press **OK**, and the model will be extended to include them:

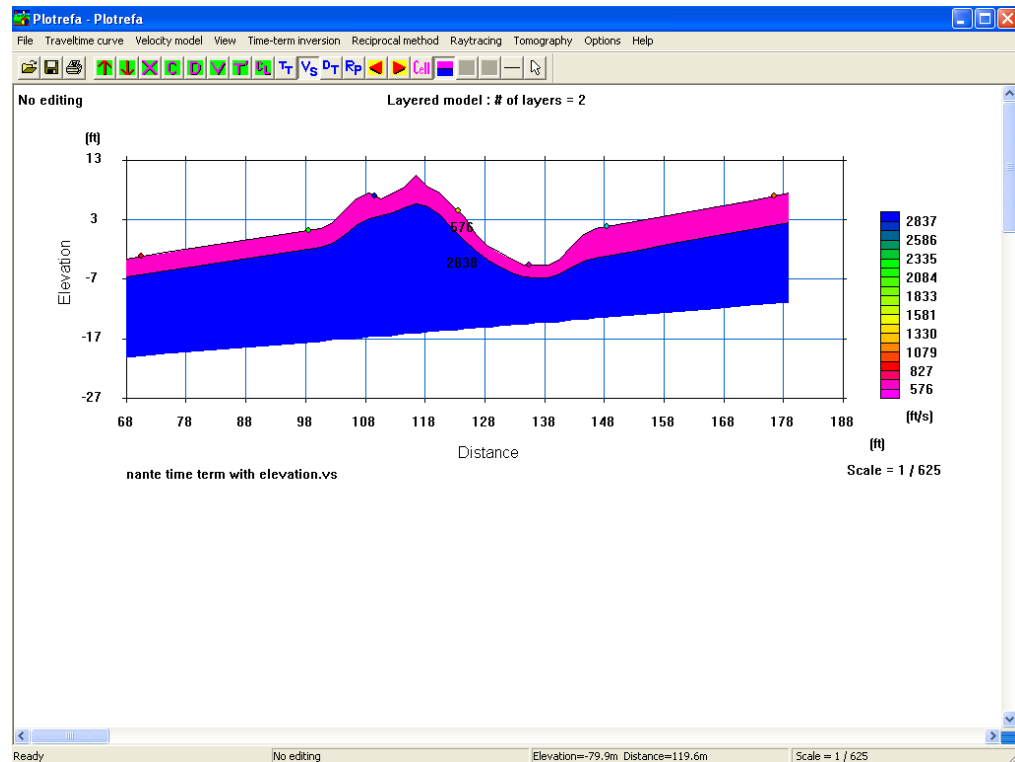

At this point you may refine the model as usual using the tomography module, and the remote sources will be included in the analysis. In this particular case,

since the topography is significant, a tomographic analysis is the best approach. We use the above model as the initial model and invert:

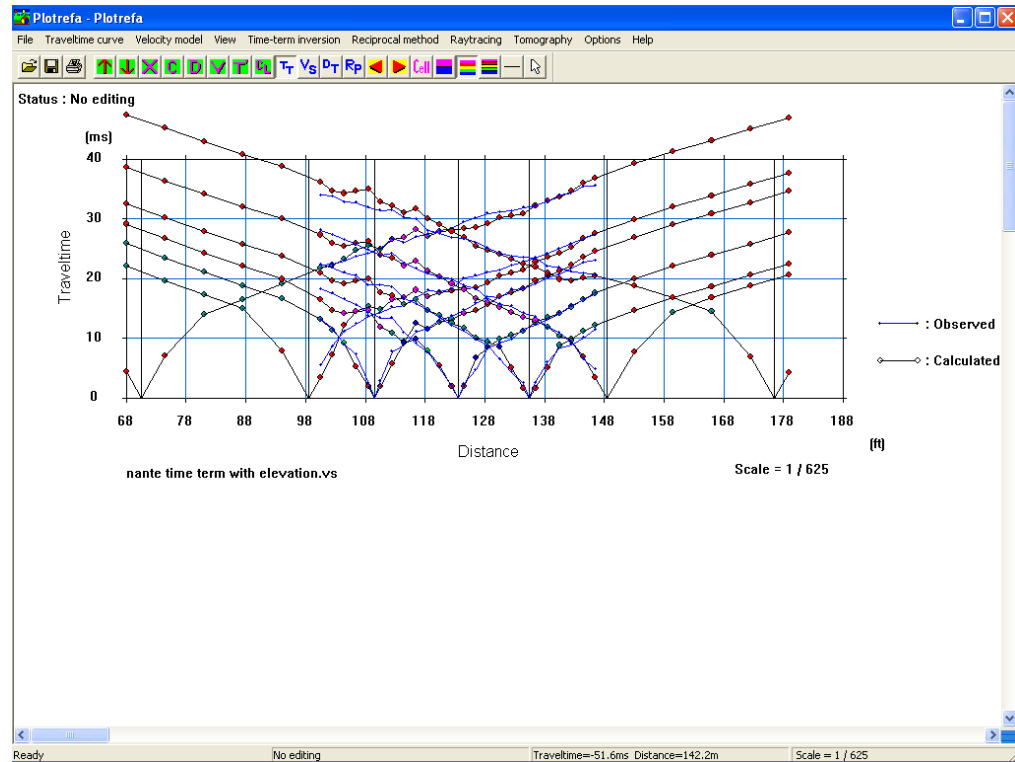

Note now that theoretical data have been calculated for all sources, including remote ones. The travel times outside of the spread are calculated from extrapolated velocities and should be ignored.

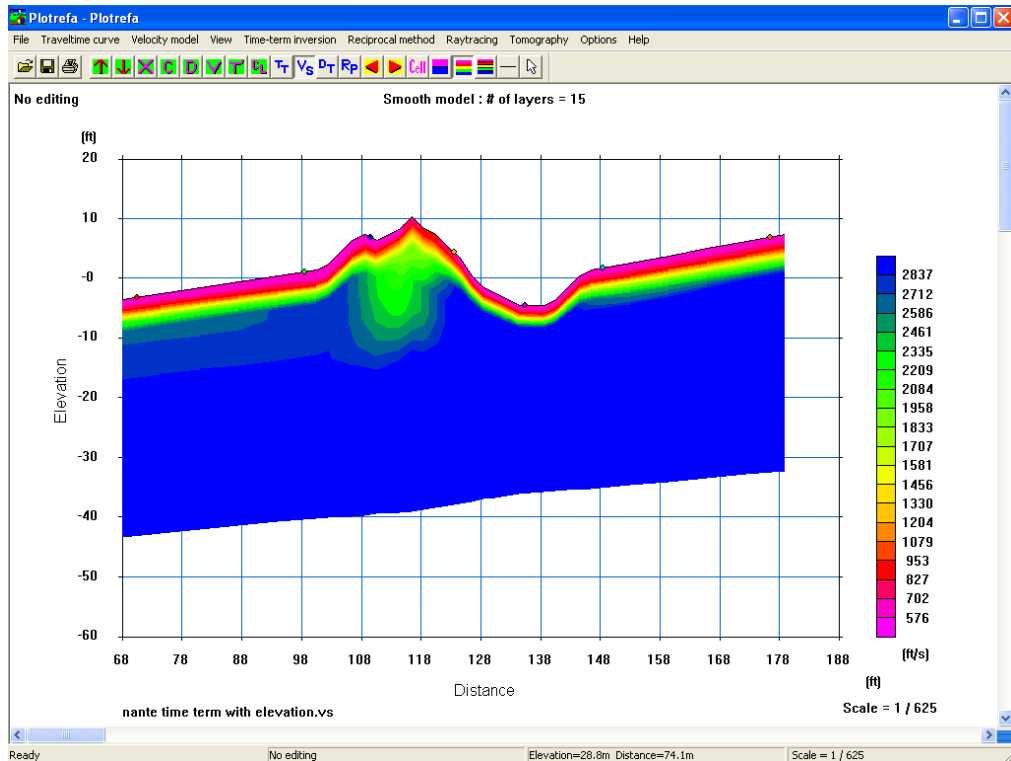

At this point, you can trim down the result to show only the zone within the geophone spread:

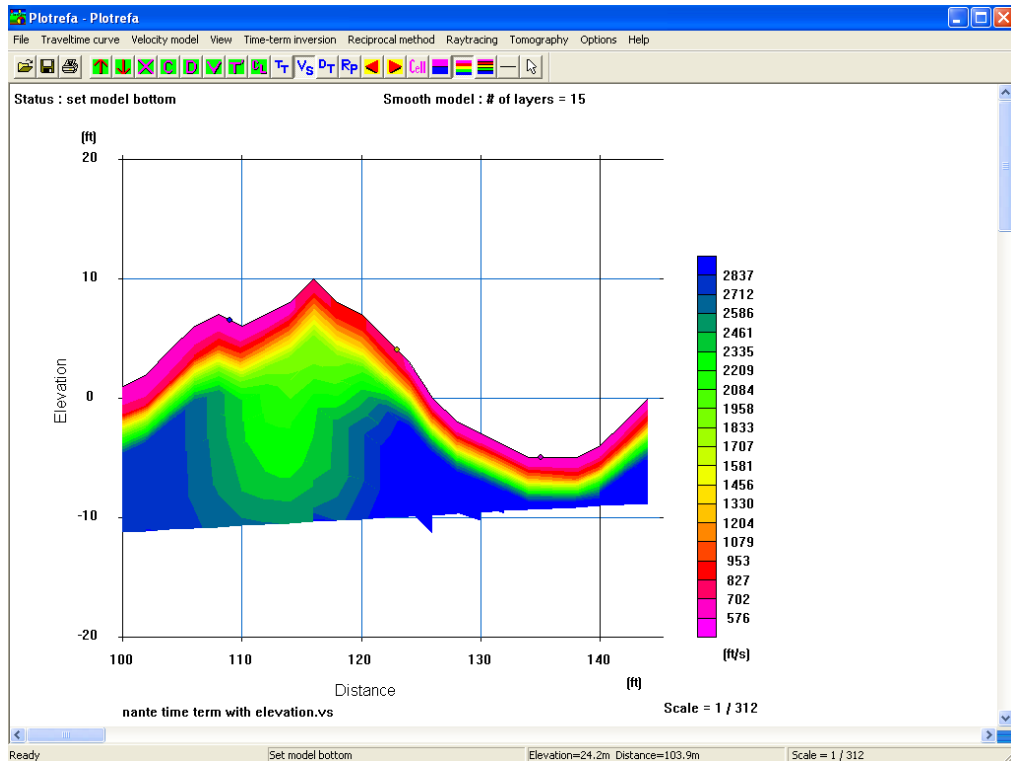

4.3.23 Modeling

Plotrefa includes the capability of creating a custom velocity model for forward modeling purposes. You may create a simple layer-cake initial model, and then customize it further using the editing techniques discussed above. Once you have completed your model, you may use the ray tracing routine (discussed in [Section 4.7](#)) to compute theoretical traveltimes for the model.

4.3.23.1 Generate New Velocity Model

To make a new velocity model, choose “Generate new velocity model” to reveal the following dialog box:

Specify the necessary parameters, press **OK**, and a velocity model will be created with default velocities:

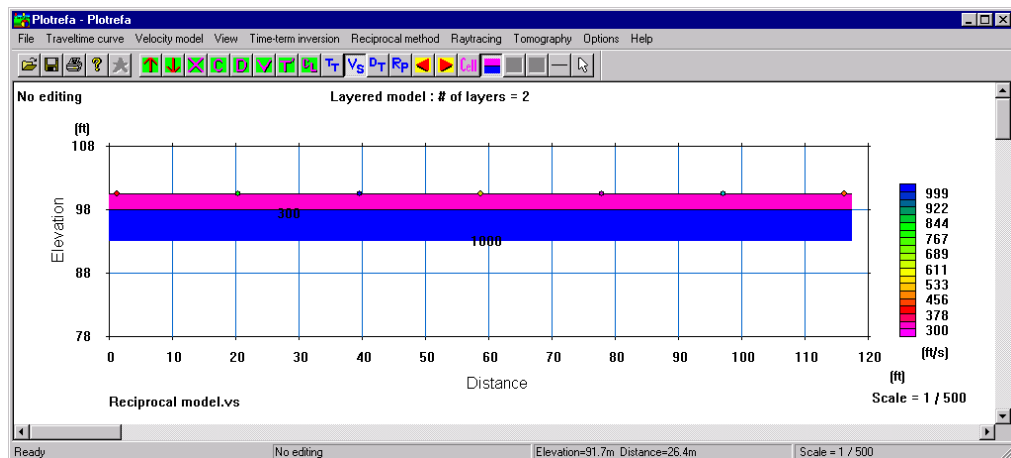

You may now customize the model as needed using the tools in the **Velocity model** menu.

Below is a customized version of the initial model:

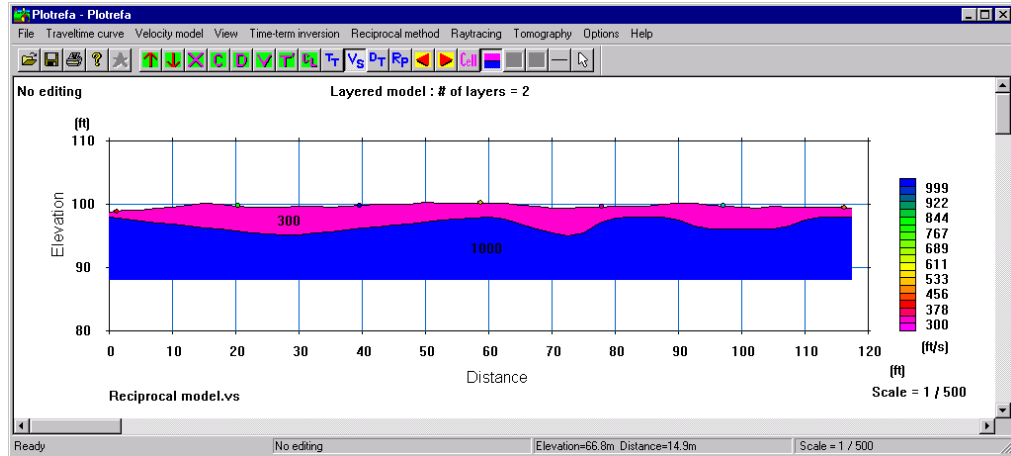

4.3.23.2 Add Random Noise to Traveltime Data

If you calculate synthetic traveltimes using the **Raytracing** menu, you may add random noise to them. Below are the synthetic traveltimes generated for the model above:

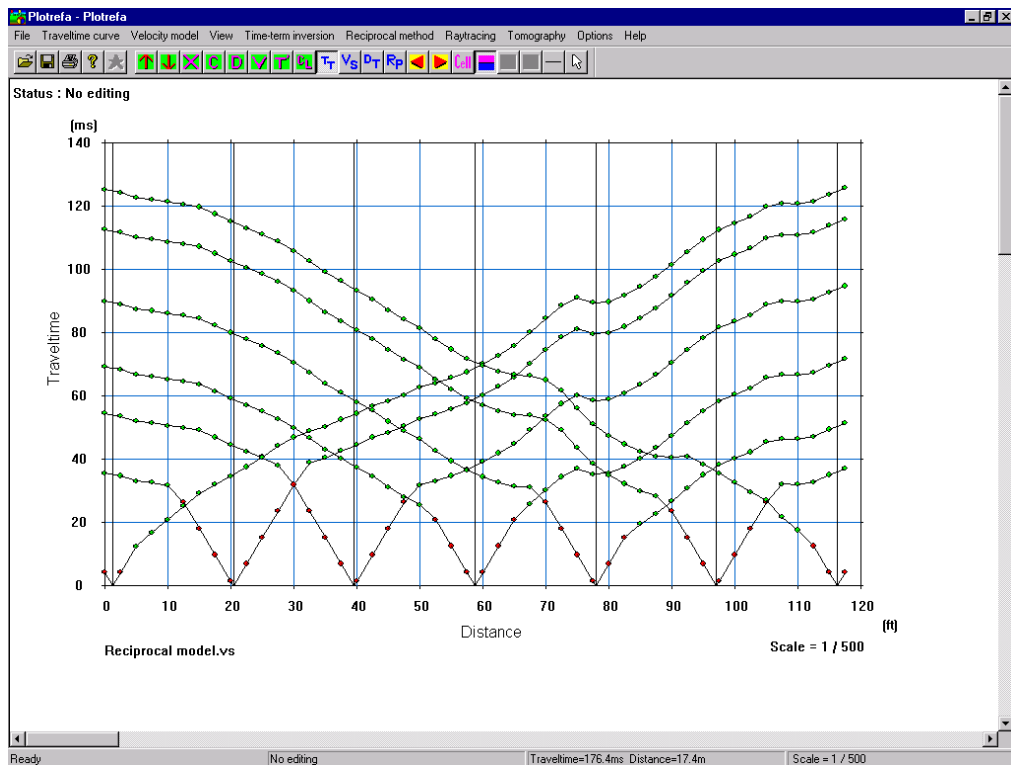

Choose “Add random noise to traveltime data” to reveal the following dialog box:

Indicate the [standard deviation] noise range in milliseconds, and press **OK**:

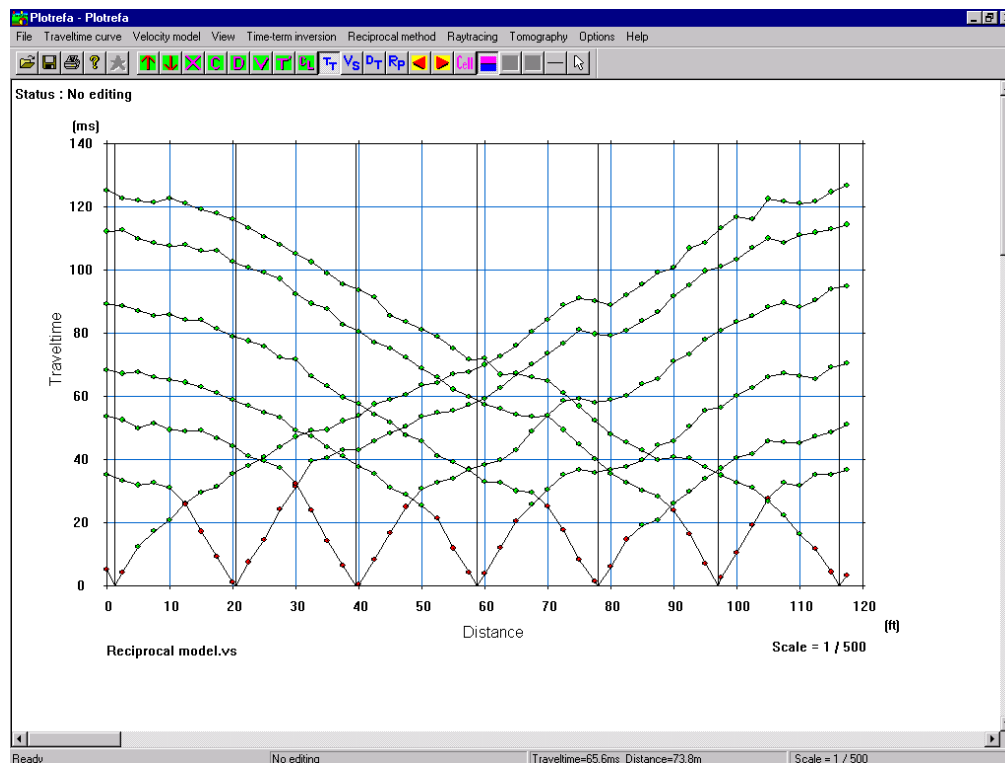

Your data will now have a random noise component superimposed on it.

4.3.23.3 Convert Synthetic Data to “Observed” Data

It is often useful to convert synthetic traveltime data calculated from a synthetic model into “observed” data. This basically tricks the program into thinking that the synthetic data is actually real data, allowing you to treat it as such. This is a necessary step if you wish to invert this synthetic data and compare the resulting model to the original input model. This forward/inverse modeling can be very useful in testing the capabilities of the various inversion techniques on various types of seismic models. For instance, if you wanted to test the fault-detecting ability of tomography, you might follow the following steps:

- 1) Create a faulted velocity model.

- 2) Use the **Raytracing** menu to calculate the synthetic traveltimes.
- 3) Add a reasonable level of random noise to you data.
- 4) Convert the synthetic data into “real” data.
- 5) Do a tomographic inversion of the “real” data.
- 6) Compare the initial model to the calculated model
- 7) The new synthetic data will now be displayed along with the “observed” data (below).

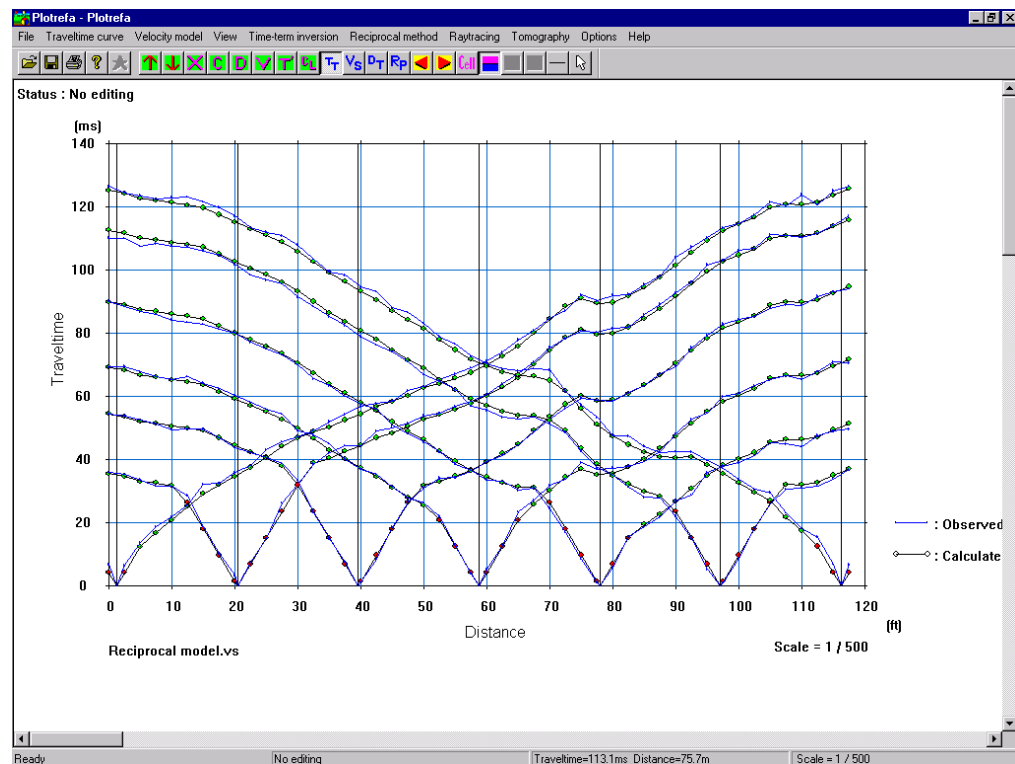

See the forward modeling example in the examples booklet.

4.4 **View Menu**

Click on “View” to show the **View** menu:

This menu gives you control over various display parameters. It allows you to configure the axes, determine which graphics to view, and set the scale.

4.4.1 **Axis Configuration (Manual)**

You may customize the axes of the traveltime plot and the velocity section. Click on “Axis configuration (manual)” to reveal the following dialog box:

The X-axis will always be in units of length (set in the **Options** menu, discussed in [Section 4.9.2](#)); the units of the Y-axis will depend on what is

being displayed when you choose to customize the axes. If the velocity section is displayed, the Y-axis will be in units of length. If the traveltime plot is displayed, the Y-axis will be in units of time.

You may also control the number of traveltime curves that are displayed.

Experiment with the various parameters to see their effects.

4.4.2 Axis Configuration (Automatic) [

If you would like the axes to be configured automatically, choose “Axis configuration (automatic)”.

4.4.3 Apply Custom Axis Configuration

If you have created a custom axis file (see next section), you may apply that configuration to the current plot. Click on “Apply custom axis configuration”. Choose the appropriate .prm file, and the plot will be configured accordingly.

4.4.4 Save Current Axis Configuration

If you have created a custom axis configuration manually, you may save this configuration for use on subsequent models. Click on “Save current axis configuration”. You will be presented with a dialog box similar to that shown above. Provide a filename and press **Save**.

4.4.5 Show Traveltime Curves [

If you wish to view the traveltime plot, click on “Show traveltime curves”, or press the  tool button.

4.4.6 Show Velocity Model [

If you wish to view the velocity model, click on “Show velocity model”, or press the  tool button.

4.4.7 Show Time-term [

As will be discussed in future sections, the time-term and reciprocal methods modules are based on the concept of “time-terms” or “delay times”. The calculated delay times are use in conjunction with the associated velocities to generate the velocity/depth section. If you would like to view the delay times, click on “Show time-term”, or press the  tool button. The delay times will be presented in a plot similar to the one shown below:

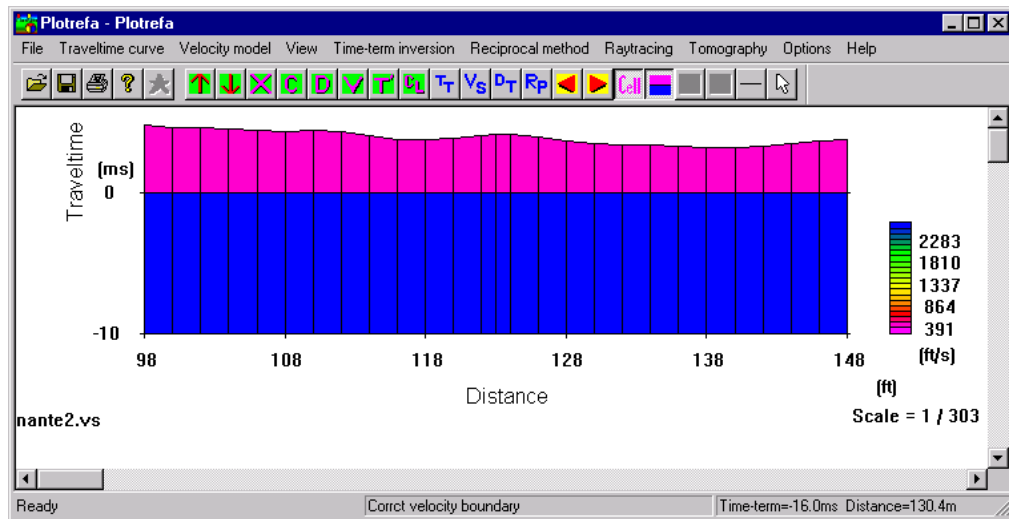

4.4.8 Show Raypath [

If you have run your model through the ray tracing routine (discussed in [Section 4.7](#)), and you would like to view the ray paths, click on “Show

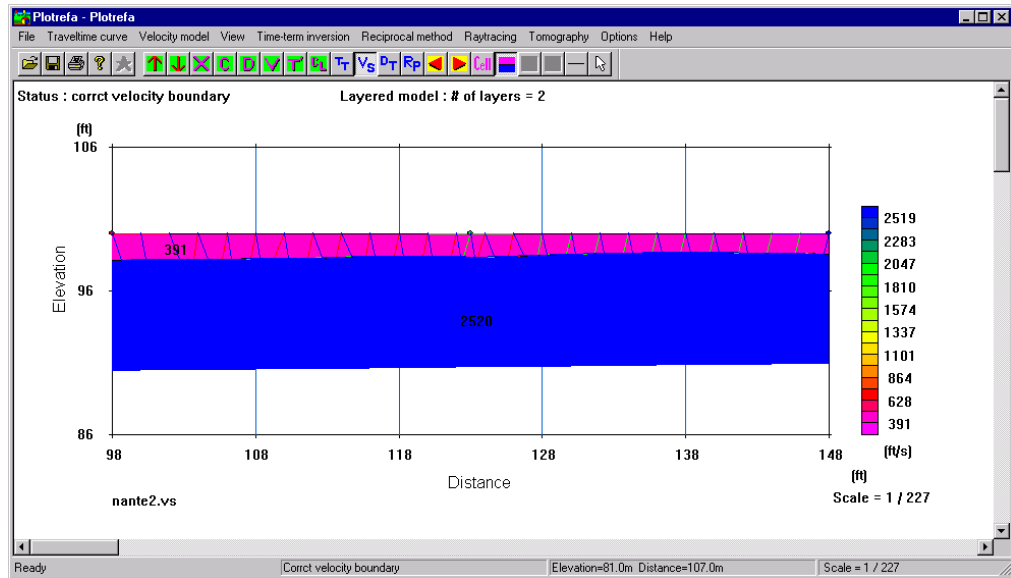

raypath”, or press the tool button. A ray path diagram similar to that shown below will be displayed:

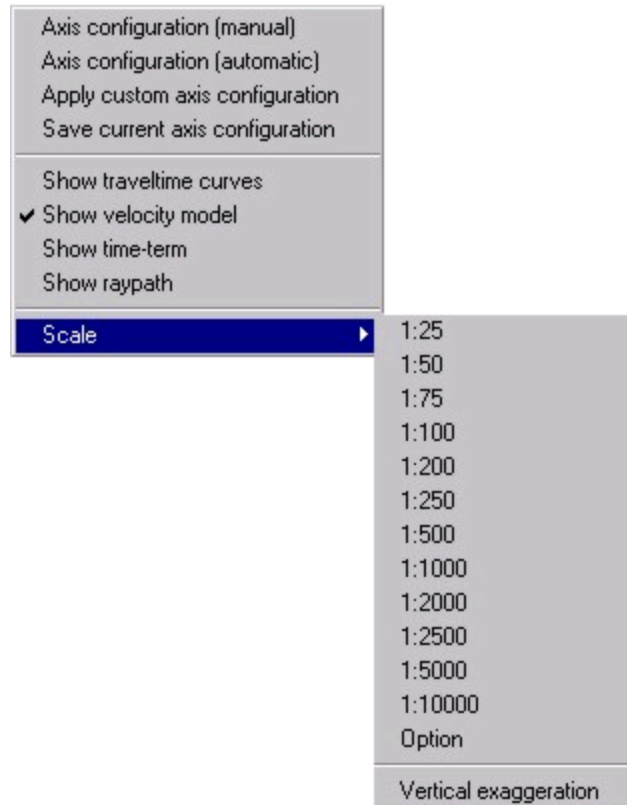

4.4.9 Scale

There are several ways to set the scale of your output. If you click on “Scale”, you will see the following sub-menu:



Choose from any one of the scales listed, or click on “Option” and enter whatever scale you want. Alternatively, you may increase/decrease the scale by pressing the  or  tool buttons, respectively.

If you would like to change the aspect ratio, click on “Vertical exaggeration” and enter the desired ratio.

4.5 *Time-term Inversion Menu*

Click on “Time-term inversion” to reveal the **Time-term Inversion** menu:

We will now discuss the first of three inversion techniques. Which technique you employ will depend on the goals of your survey. In a fashion consistent with what we have done so far, each menu item for each technique will be discussed individually. Examples of each of the three interpretation techniques are given accompanying examples booklet.

The “Time-term” technique employs a combination of linear least squares and delay time analysis to invert the first-arrivals for a velocity section. It is a good approach for lower-budget, simple refraction surveys, in which refractor detail is of lesser importance than gross velocities and depths. A good example might be a rippability survey. These types of surveys are typified by 12 or 24 channels, with as few as two shots per spread. The answer usually does not need to be a detailed one, and minimizing the time between fieldwork and the deliverable to the client tends to trump all.

A brief explanation of the time-term technique is given in [Appendix B](#).

The general flow of the time-term technique is displayed in the flow chart below:

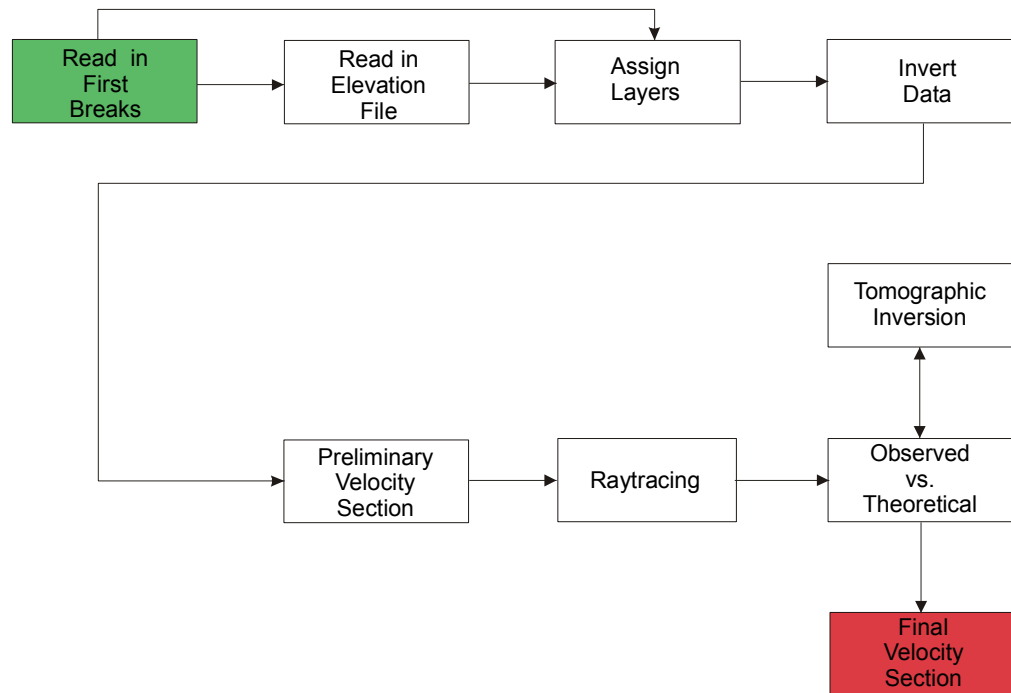

4.5.1 Assign Layer 2 Arrivals

A simple time-term analysis allows a two- or three-layer interpretation. If you have a three-layer case, you should assign arrivals for the second layer first. Read in your first breaks and click on “Assign layer 2 arrivals”. To assign layers, click on the traveltimes closest to the change in slope associated with the second layer. In the figure below, the cursor is pointing to the first traveltimes from the second layer for the left-most shot. Note that all subsequent traveltimes for that shot are now shown in green:

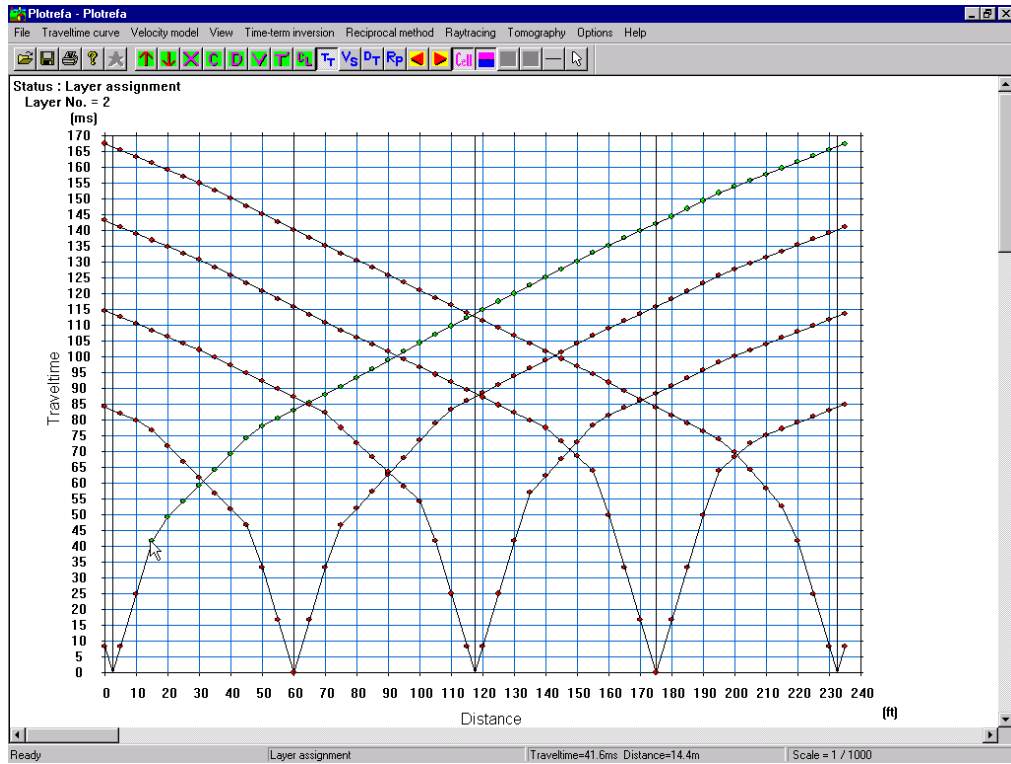

Assign layer two to all shots:

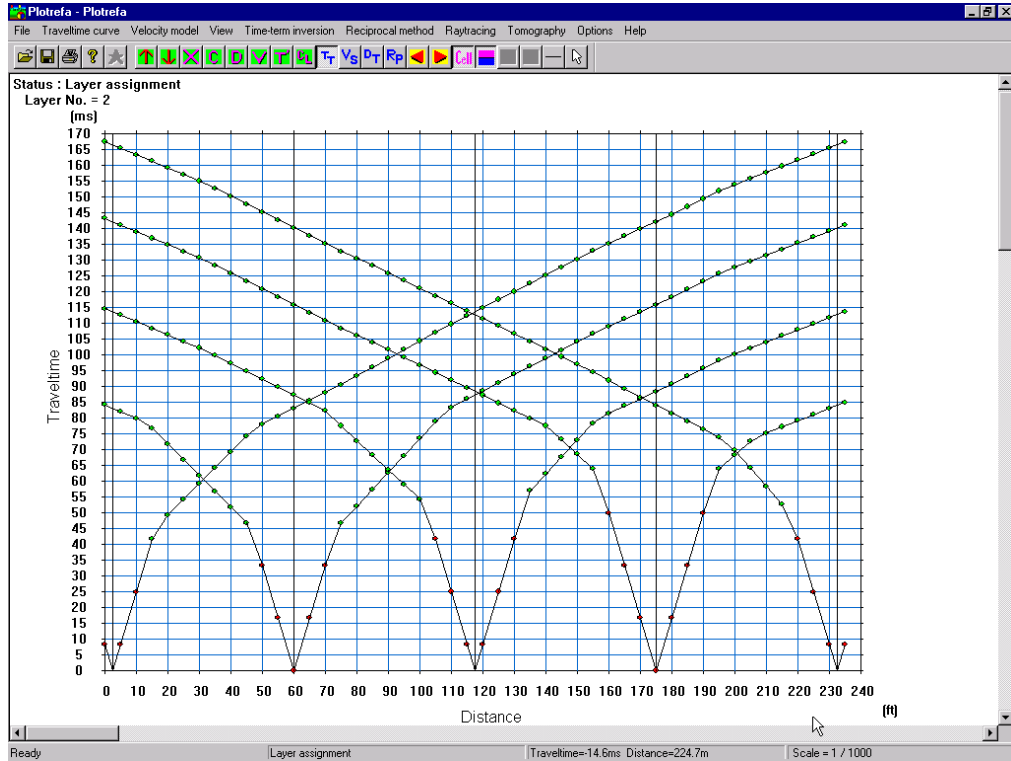

If it is a two-layer case, you are finished assigning arrivals.

4.5.2 Assign Layer 3 Arrivals

If there is a third layer, you must repeat the process for layer three. Choose “Assign layer 3 arrivals” and follow the procedure detailed above. In the figure below, the cursor is pointing to the first layer-three arrival from the left-most shot:

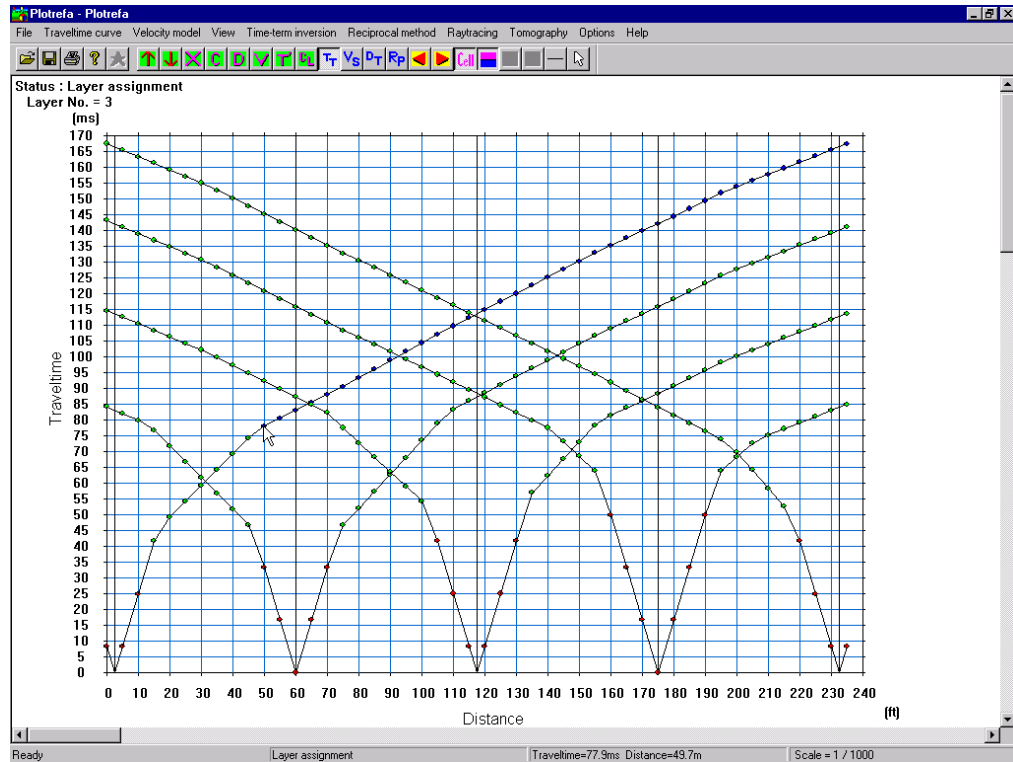

Below is the full three-layer interpretation:

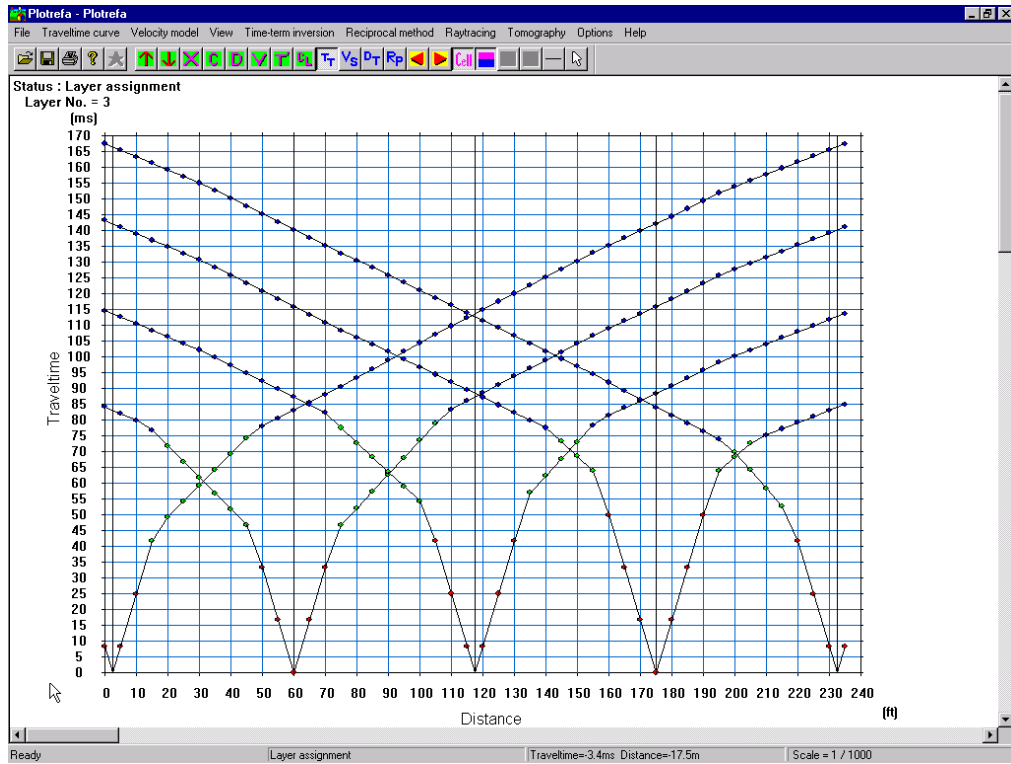

Note: When travel times from different shots coincide at a hinge point, it can be difficult to assign layers to both travel time curves. When this happens, the best remedy is to display a partial traveltime plot at any one time, as discussed in section 4.10.1.



Audio/video clip of Layer Assignments

4.5.3 Do Time-term Inversion

Once all of the layers have been assigned, you are ready to invert the data for the velocity section. Click on “Do Time-term inversion”. The inversion error will be displayed:

*Note: The message above does **not** indicate a failure. It is reported every time you do a time-term inversion. It is simply a measure of the quality of the least-squares inversion. Generally, a matrix inversion error of 1.5 or less is acceptable. If it is larger, you might want to re-examine your picks and/or layer assignments.*

Press **OK** and the velocity section will be revealed:

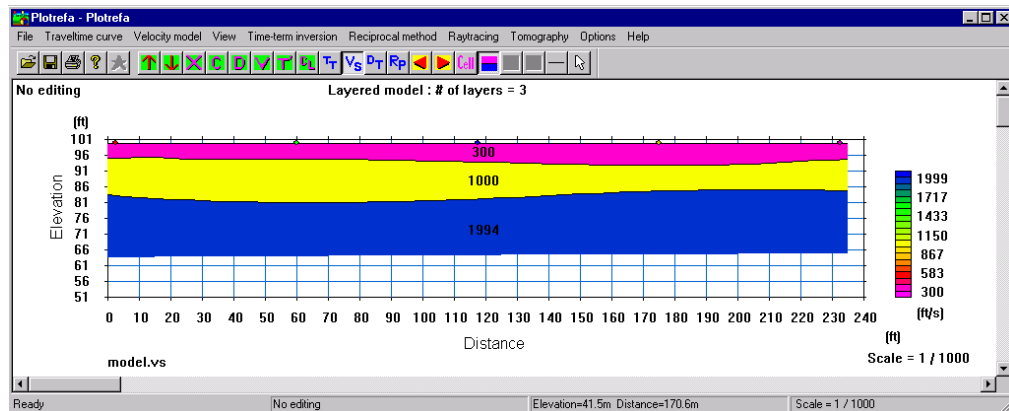

4.5.4 Clear Layer Assignment

At any time, you may clear the current layer assignments and start over. Simply click on “Clear layer assignment”.

4.6 *Reciprocal Method Menu*

Click on “Reciprocal method” to reveal the **Reciprocal Method** menu:

The “Reciprocal method” of interpretation is a powerful technique for solving more complex refraction problems. It works best with highly redundant data (many shots), 24 channels or more per shot, and requires a far greater degree of input from the interpreter compared with the time-term method. This technique can provide a refractor depth beneath each geophone, provided a delay time for that geophone can be determined. This, in turn, requires “overlap” – to calculate a delay time for a particular refractor for a particular geophone, you must have an arrival from that refractor from opposing directions. This has implications for how the data are acquired in the field, and will be discussed in further detail below.

The general flow of a reciprocal time inversion is shown in the following flow chart:

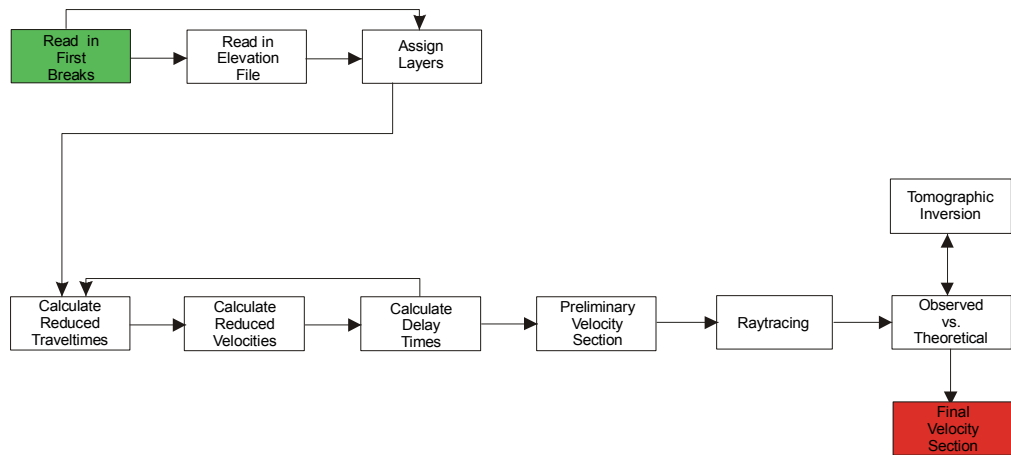

If you are doing a simple rippability survey, the reciprocal method is overkill. You will do a lot more work and yield a marginally more useful answer. But if you are trying to image a fault or a buried stream channel, this technique can often provide a superior image. To learn more about the reciprocal method, see [Redpath \(1973\)](#), and Palmer (1980, 1981, 1990).

Below is an example of a refraction record that nicely lends itself to interpretation by the reciprocal method:

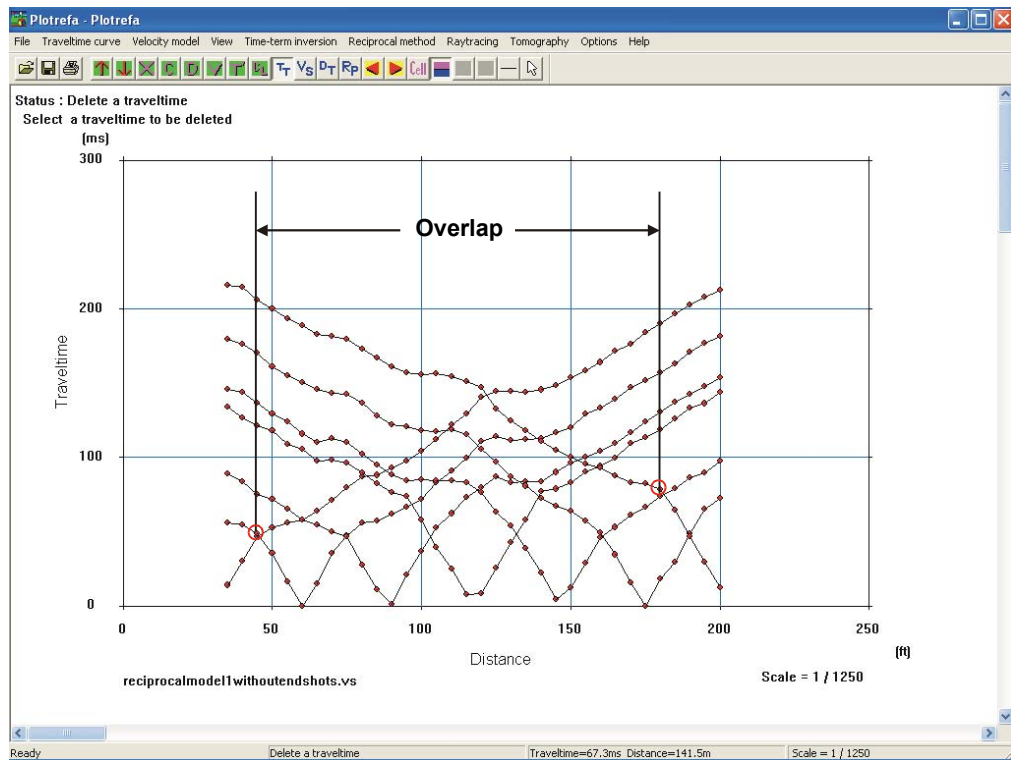

Note the redundancy of the data. This is very important, because the reciprocal method makes much *use* of the scatter of the data about a best-fit line – in this type of interpretation, this is considered *signal*, not noise. It yields crucial information about the geometry of the refractor. But scatter about the best-fit line can have several other sources, not the least of which is errors in picking. For this reason, redundancy, achieved through numerous shots, is critical. It helps you to separate real structures from artifacts due to picking errors.

Note also the region of overlap. It is over this segment of the geophone spread where delay times can be calculated. Outside of this zone, the reciprocal method will not provide a solution.

We will now step through each of the items in the **Reciprocal Method** menu.

4.6.1 Layer Assignment

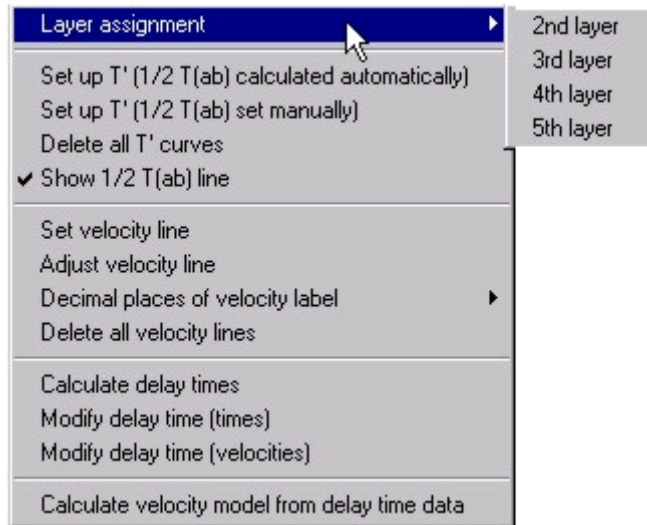

Layers are assigned as discussed in [Sections 4.5.1 and 4.5.2](#). The **Reciprocal Method** menu differs from Time-term in this regard, allowing up to 5 layers to be interpreted.

4.6.2 Set up T' ($1/2T_{(ab)}$ calculated automatically) [

The T' ("T-prime") or "reduced traveltime curve" is a useful tool for determining refractor velocity. It essentially strips away the effects of the overlying layer, as if the shots and geophones were laid directly on the refractor. The T' curve is drawn relative to one-half the reciprocal time ($1/2T_{(ab)}$). If you wish $1/2 T_{(ab)}$ to be calculated automatically, choose "Set up T' ($1/2 T_{(ab)}$ calculated automatically)", or press the tool button. Next, click on the traveltime curves for two opposing shots, in which there is significant refractor overlap. The two traveltime curves will be highlighted, and the reduced traveltimes will be calculated and plotted:

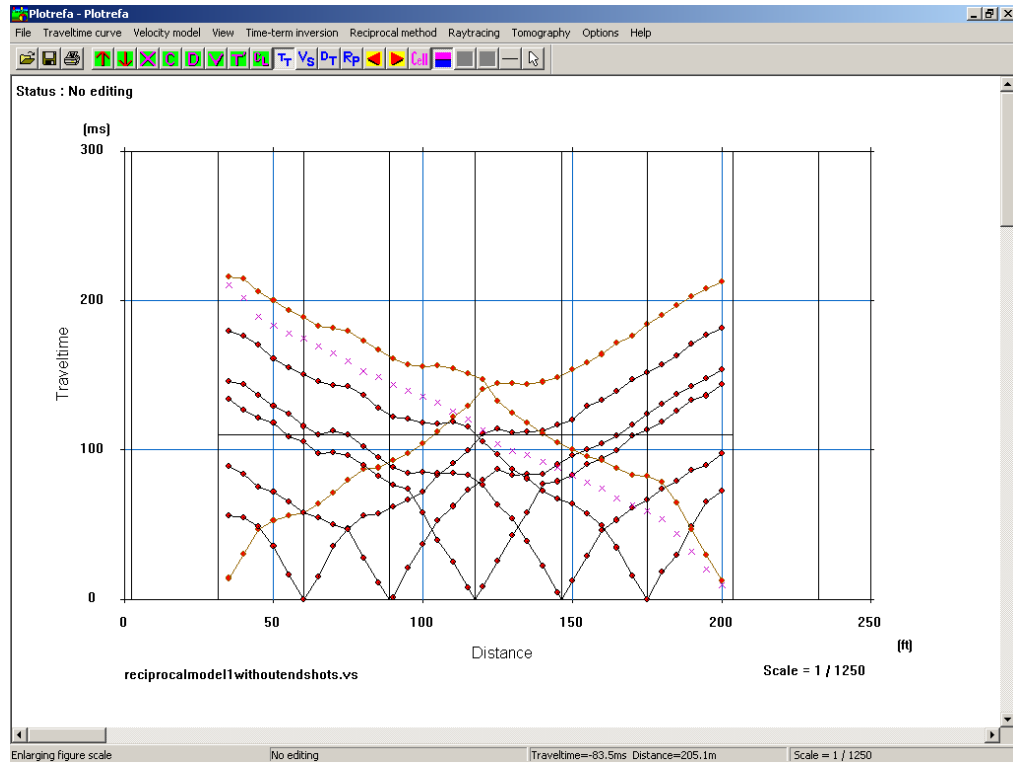

Note: The reduced traveltime curve will be parallel to the first traveltime curve that you click on.

In the example above, the two end-shots were chosen (right shot first), and the reduced traveltimes are shown in purple. The $\frac{1}{2} T_{(ab)}$ line is shown in black (about 110 msec).



Audio/video clip of Setting up T'

4.6.3 Set up T' (1/2T_(ab) set manually)

If you wish to set the $\frac{1}{2} T_{(ab)}$ value manually, click on “Set up T' (1/2T_(ab) set manually)”, choose the traveltime curves, and you will be presented with a dialog box:

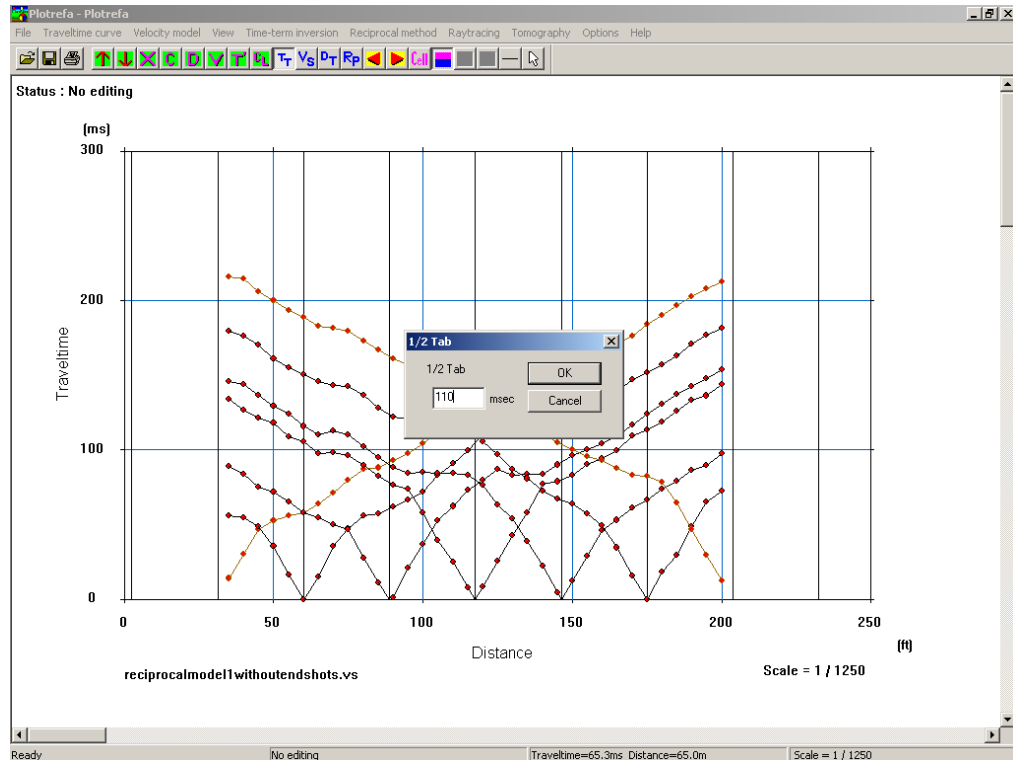

Enter the $\frac{1}{2} T_{(ab)}$ value, and press **OK**. The reduced traveltimes will be calculated and presented as shown in the previous section.

4.6.4 Delete All T' Curves

To make maximum use of the reciprocal method, you will need to calculate the reduced traveltimes for all opposing shots that have refractor overlap. Once you have done so, and used them to calculate delay times for a particular shot ([Section 4.6.10](#)), it is best to delete them to avoid confusion. To do so, click on “Delete all T' curves”.

4.6.5 Show $\frac{1}{2} T_{(ab)}$ Line [

You may choose whether or not you want to display the $\frac{1}{2} T_{(ab)}$ line on the traveltime plot. Simply click on “Show $\frac{1}{2} T_{(ab)}$ line” to toggle it on or off.

4.6.6 Set Velocity Line

After calculating the reduced traveltimes, you must determine the refractor velocity. To do so, you must fit a line to the reduced traveltimes. Click on “Set velocity line”. Next, click on the left-most traveltime, *within the region of refractor overlap*, and drag to the right-most traveltime within this region:

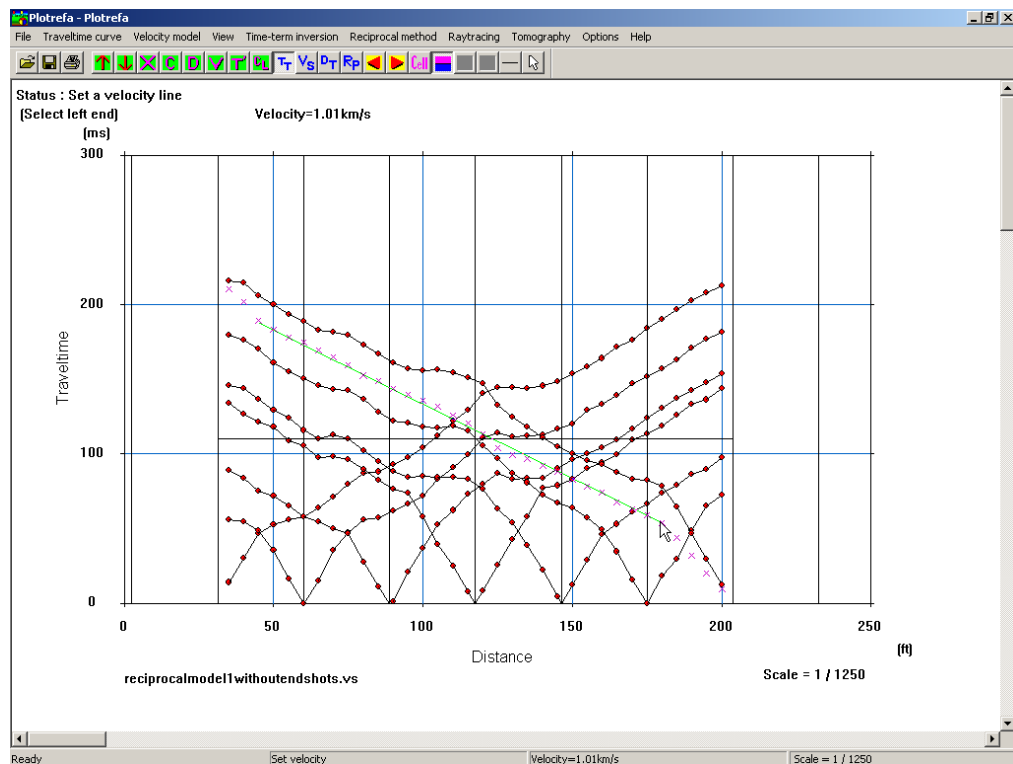

Right click to complete the velocity line:

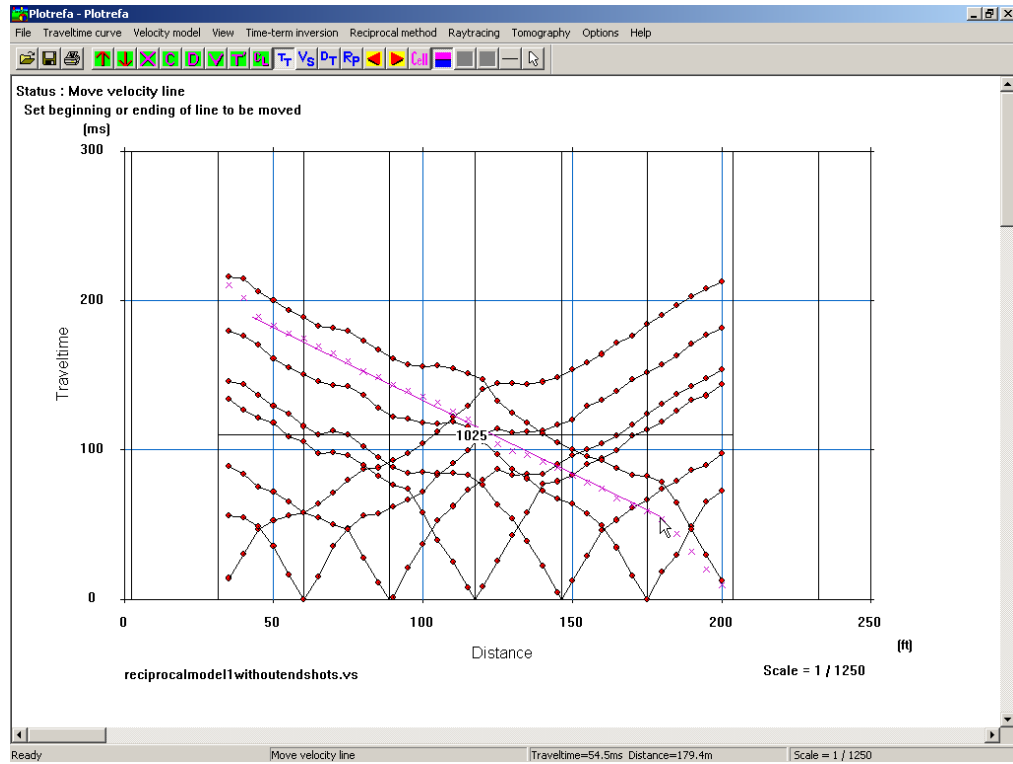

The velocity value will be displayed.



Audio/video clip of Setting Velocity Line

4.6.7 Adjust Velocity Line

After you have drawn the velocity line, you may move it to improve the fit to the data, if necessary. Click on “Adjust velocity line”, then click on one end of the velocity line. A red dot will appear to indicate that you have control:

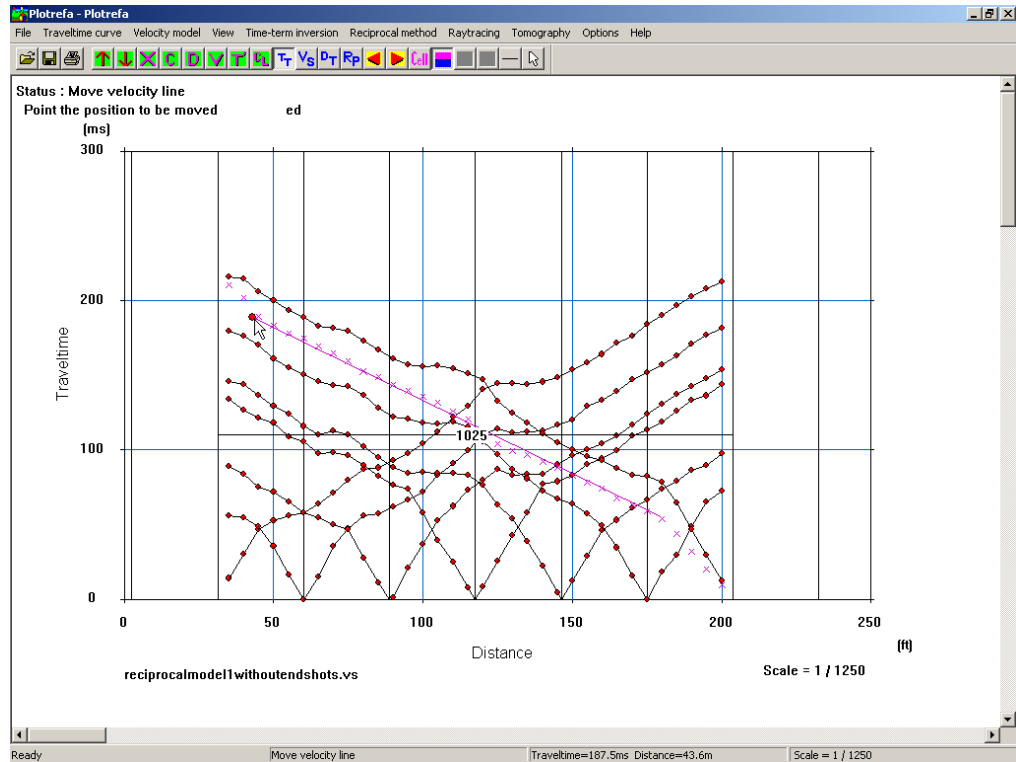

Drag the end of the velocity to the new location:

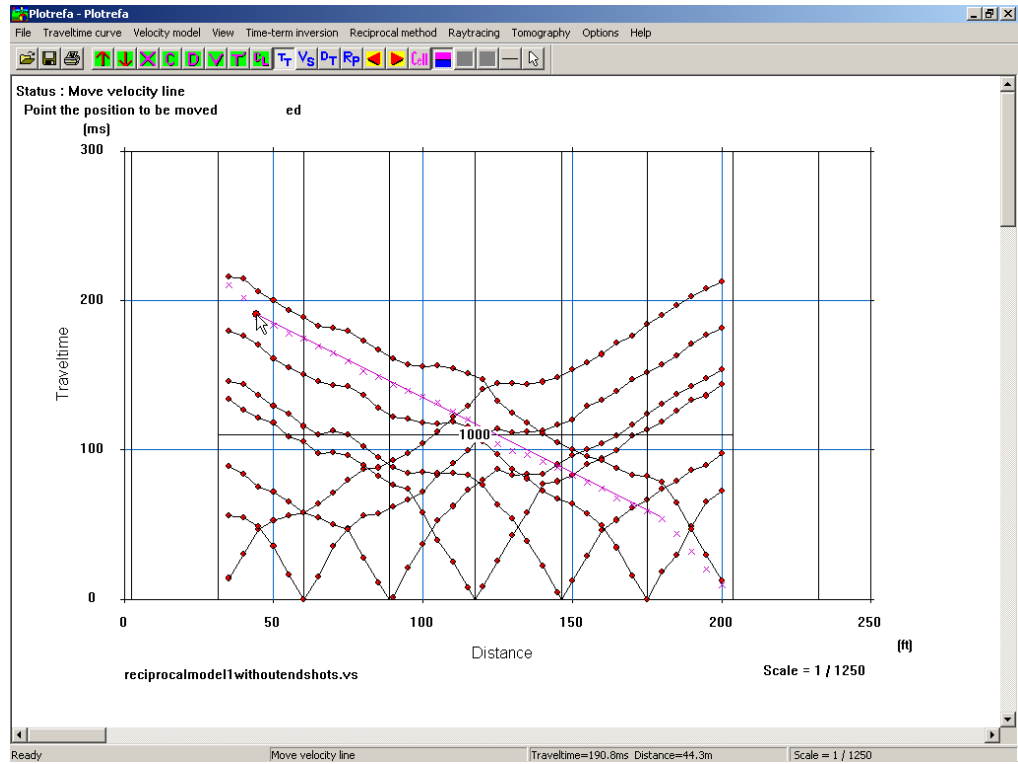

Repeat at the other end of the line if necessary.

4.6.8 Decimal Places of Velocity Label

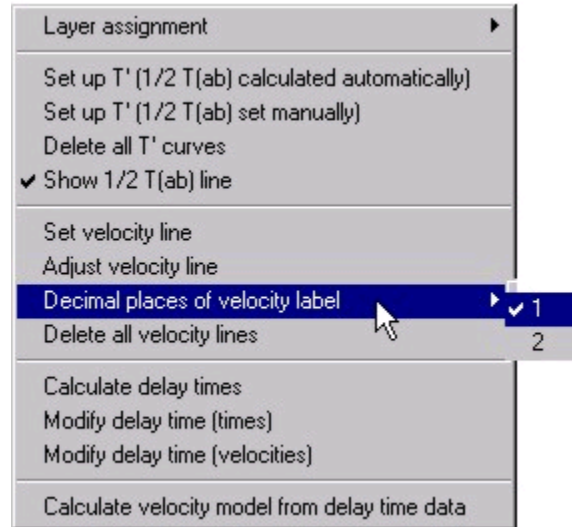

If you are working in units of kilometers, you will probably want to display velocities to at least one decimal point. Click on “Decimal places of velocity label” and choose the desired number of decimal places.

4.6.9 Delete All Velocity Lines

For the same reason you may want to delete reduced traveltime curves, you may want to delete velocity lines once delay times have been calculated for a particular shot pair. To do so, simply click on “Delete all velocity lines”.

4.6.10 Calculate Delay Times

Delay times are calculated on a shot-by-shot basis. The delay time is the difference between the measured traveltime and the associated reduced traveltime. After computing the reduced traveltime and setting the velocity line, click on “Calculate delay times”. Next, click on the velocity label to select the velocity line. When selected, the velocity line will turn red:

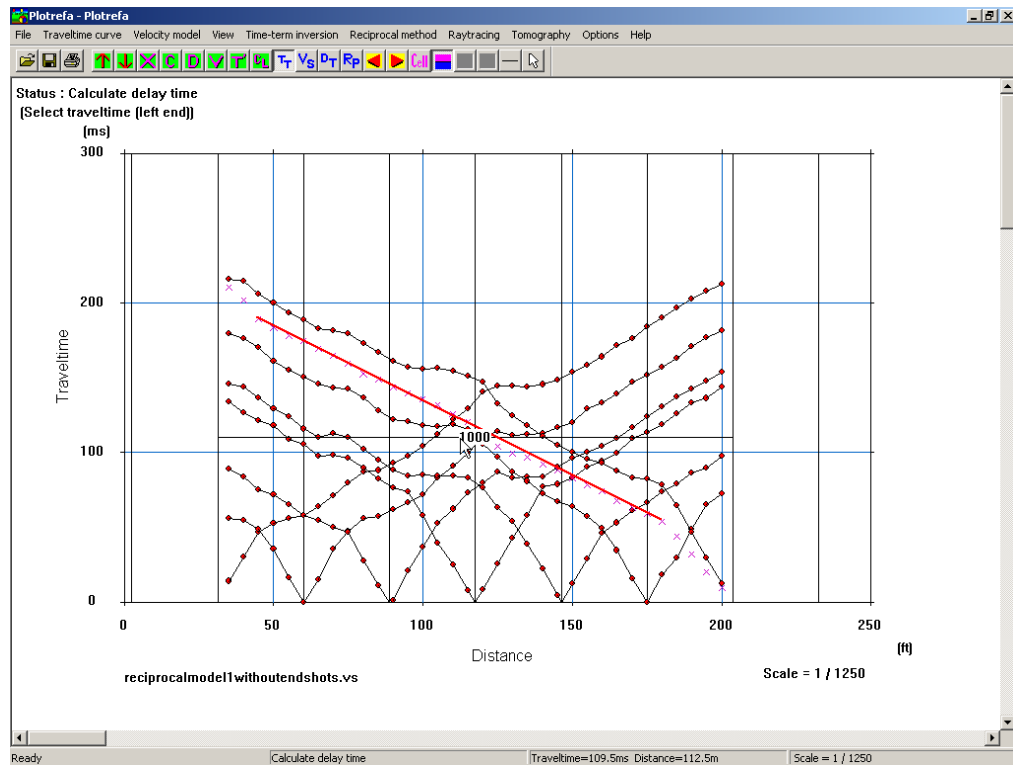

Now you must indicate the portion of the curve to compute delay times for. Like the velocity line, this should include only the region of overlap. Click on the left-most traveltime within the region of overlap, on the traveltime curve parallel to the reduced traveltime curve:

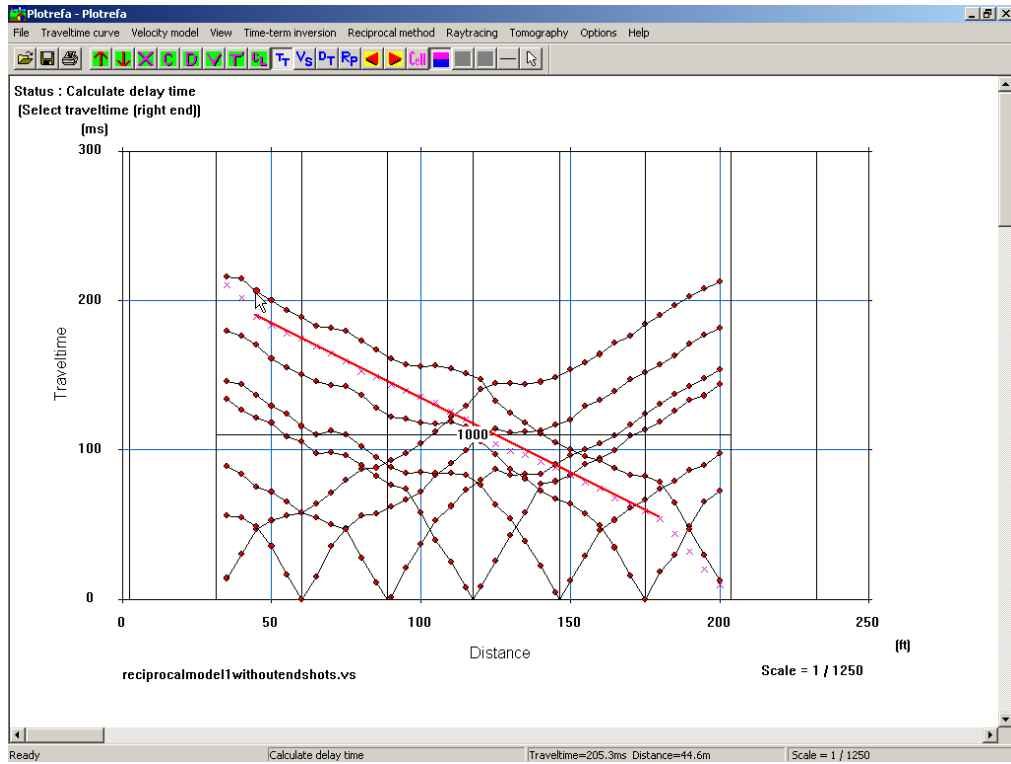

Next, click on the right-most traveltimes in the region of overlap:

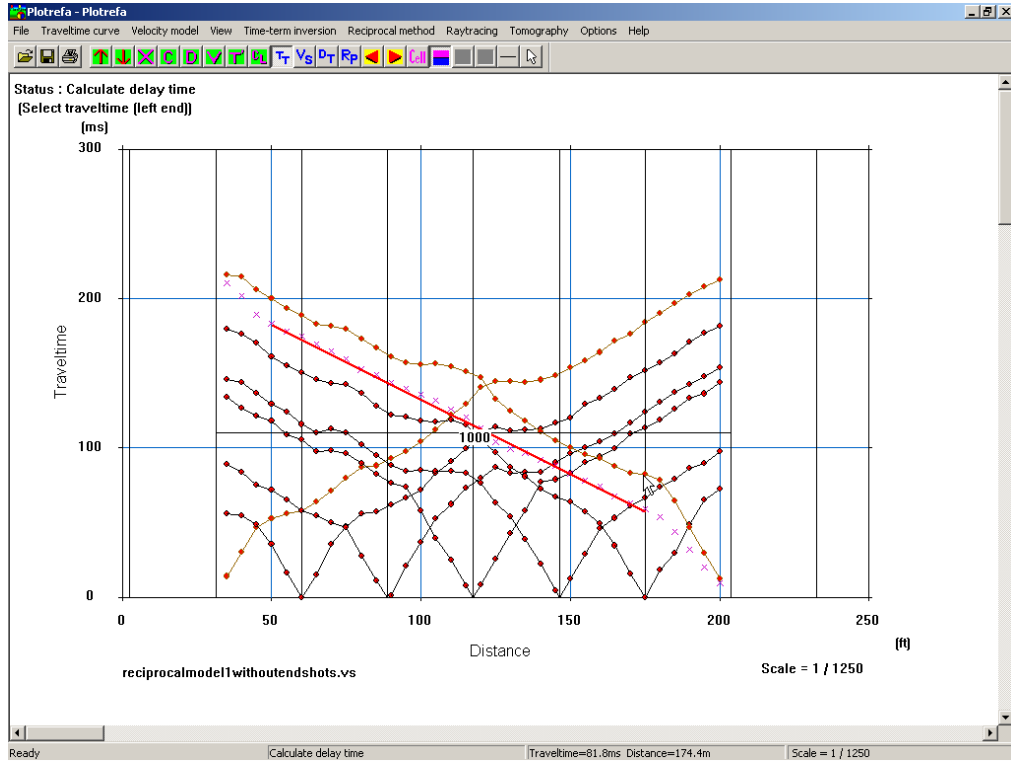

You will be presented with the delay times for that shot:

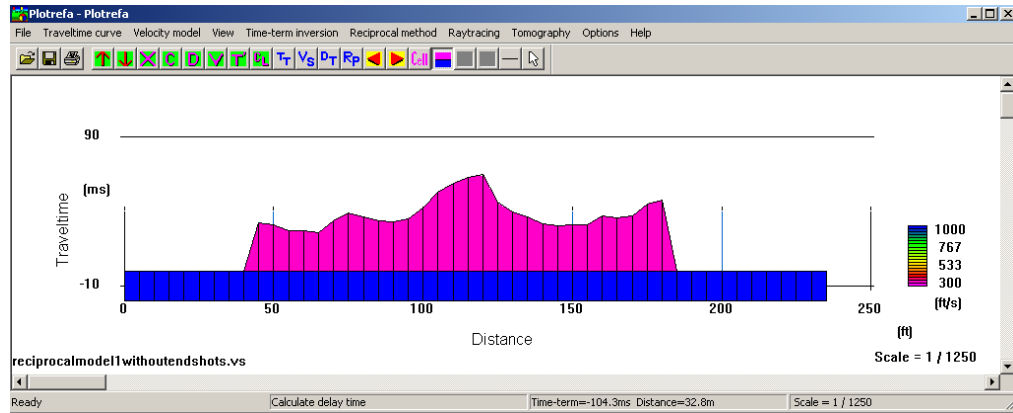

You should do this for all opposing shots that have reasonable overlap, and for each pair, you should calculate the delay times for *both* shots in the pair. To do so for the above shot pair, we will calculate the reduced traveltimes again, but this time we will click on the *left* shot first:

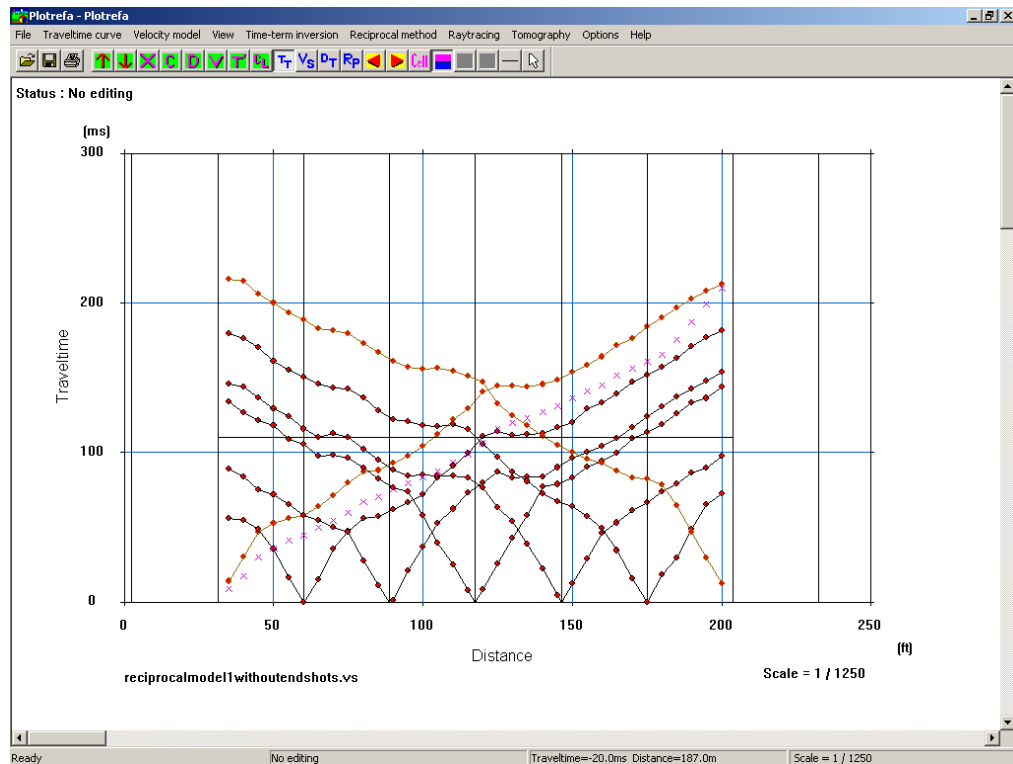

Note that the slope of the reduced traveltime curve is now in the opposite direction -- the reduced traveltimes are the same as they were before, but reversed. The delay times for the left end-shot shot can now be calculated from the differences between the left shot times and the reduced traveltimes. Simply follow the procedure detailed above for the right end-shot.

An alternative process for determining delay times is as follows:

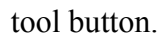
After setting the velocity line, press the  tool button. Then click on the velocity label to select the velocity line:

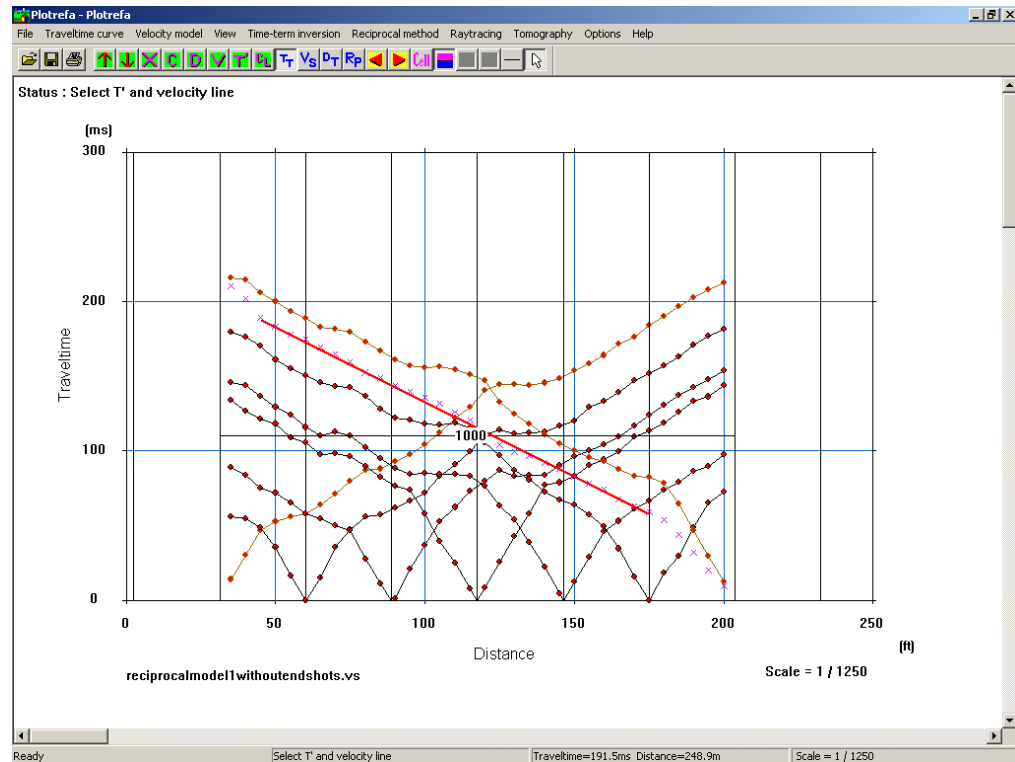

Now, right-click to bring up the sub-menu:

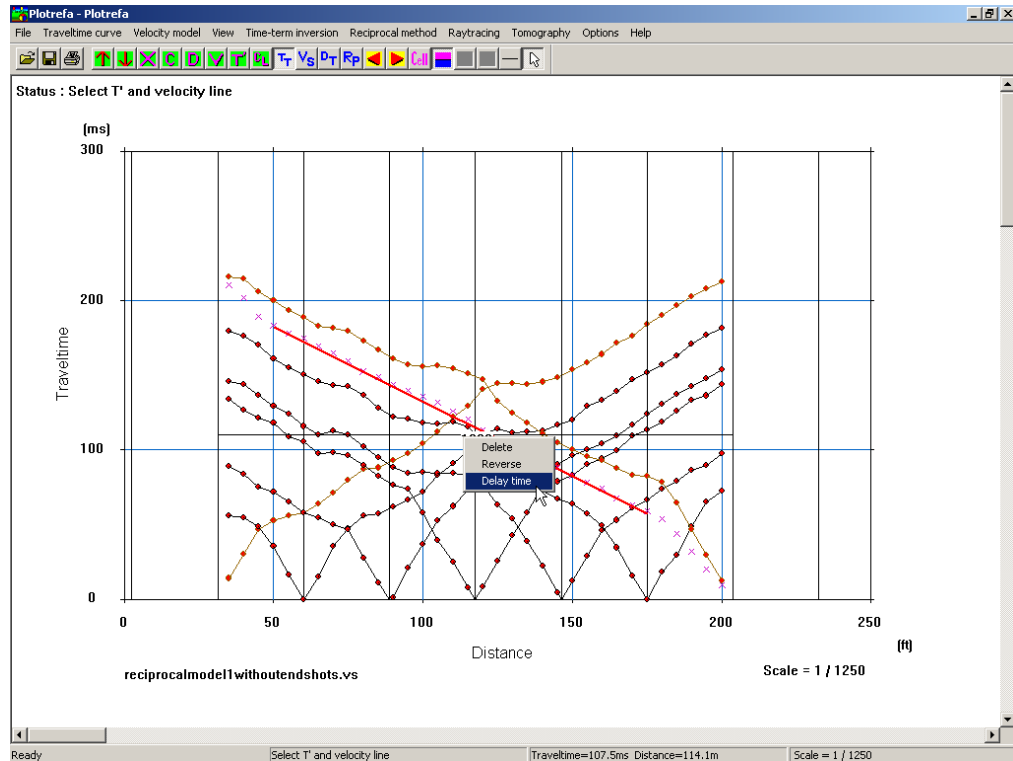

To calculate delay times for the right shot, click on “Delay time”, and then choose the segment of overlap on the traveltime plot parallel to the reduced traveltimes and click. The delay times for the right shot will be calculated and displayed:

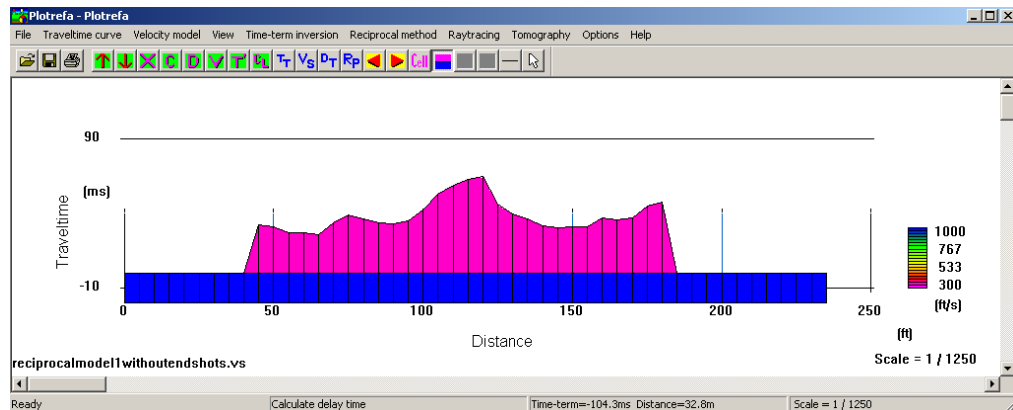

Audio/video clip of Delay Time Determination

To calculate the delay times for the left shot, right click on the velocity label to bring up the above menu again, and choose “Reverse”:

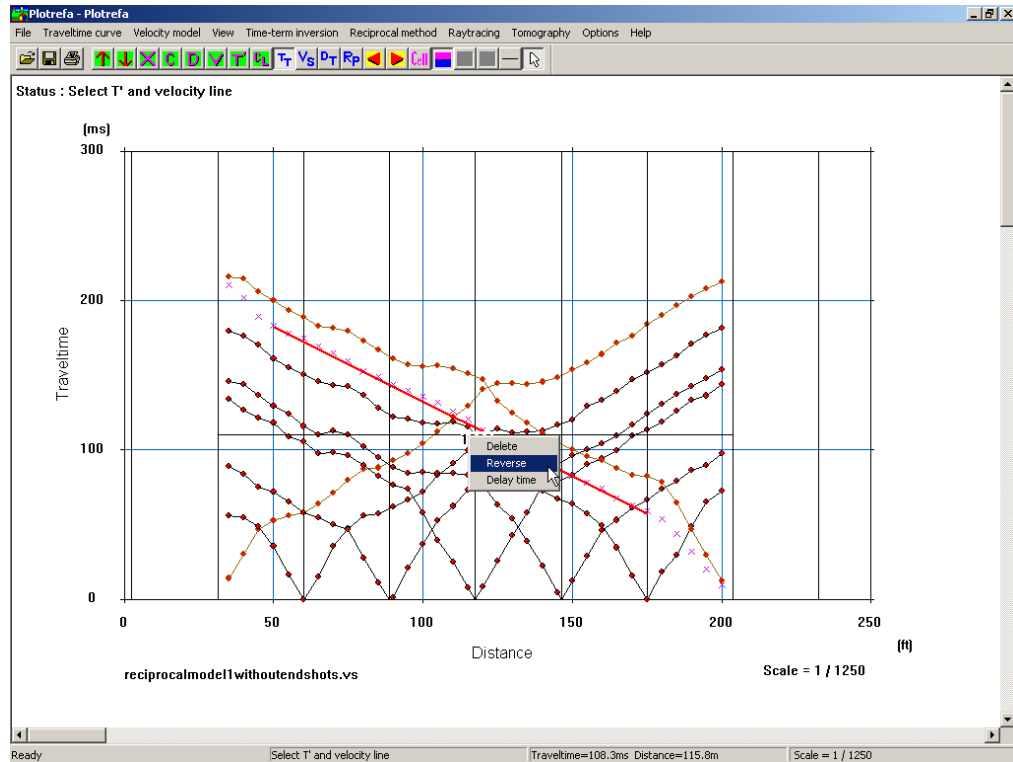

Position the cursor on the $\frac{1}{2} T_{(ab)}$ line, and click. The velocity line will be reversed:

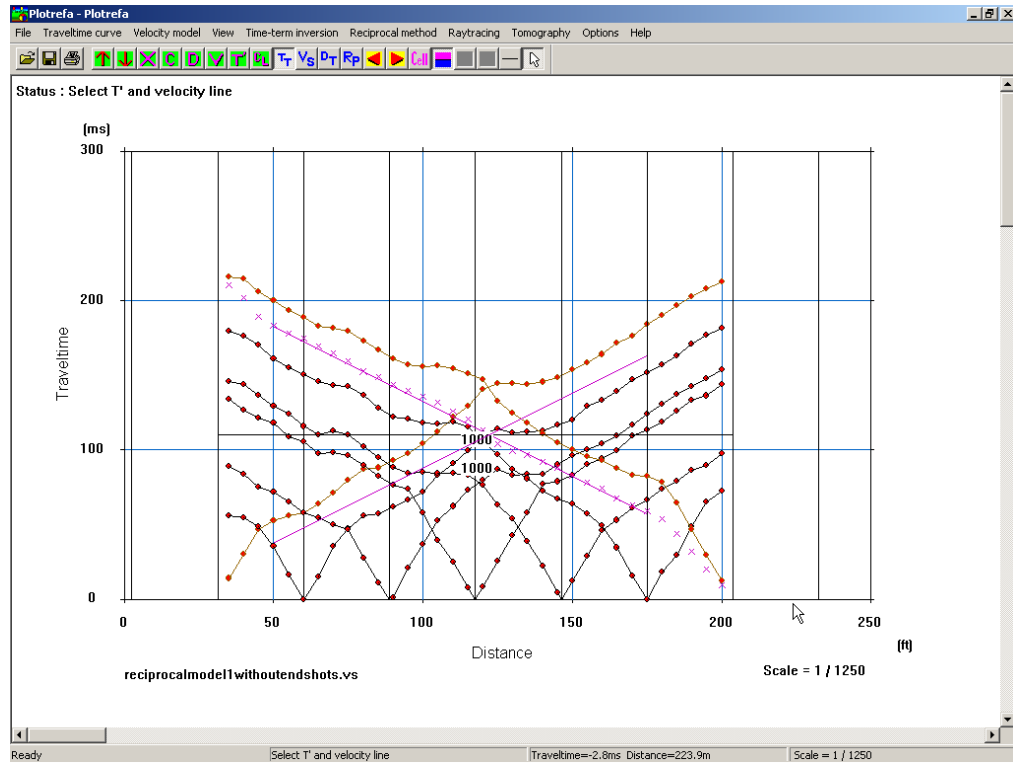

Select the new velocity line, right click, and choose “Delay times”. The delay times for the left shot will be calculated and displayed.



Audio/video clip of Reverse-shot Delay Time Determination



Audio/video clip of Entire Delay Time Calculation Process

4.6.11 Modify Delay Time (Times)

If necessary, you may modify the delay times graphically, in the same manner you can modify the layers in the velocity model ([Sections 4.3.14 – 4.3.16](#)). Click on “Modify delay time (times)”, and click on the point you wish to move:

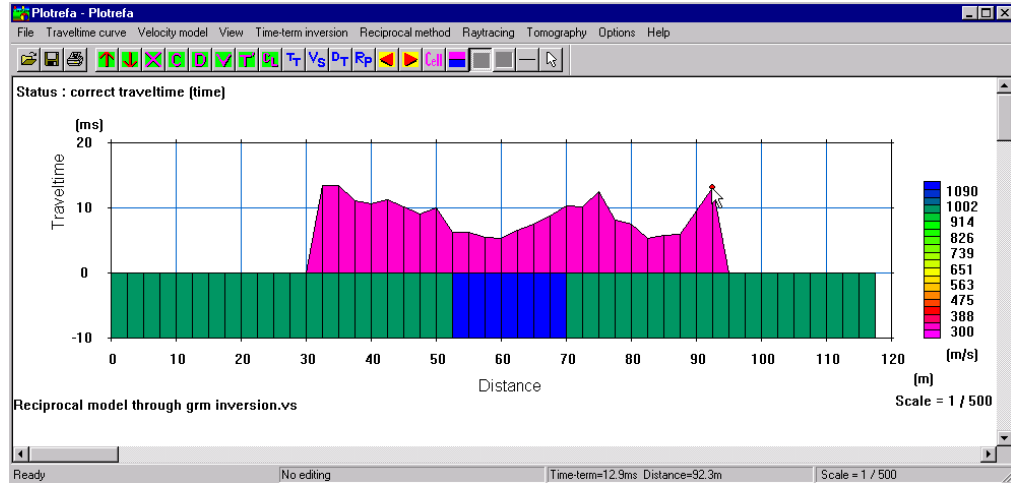

Drag the point to the desired delay time and release:

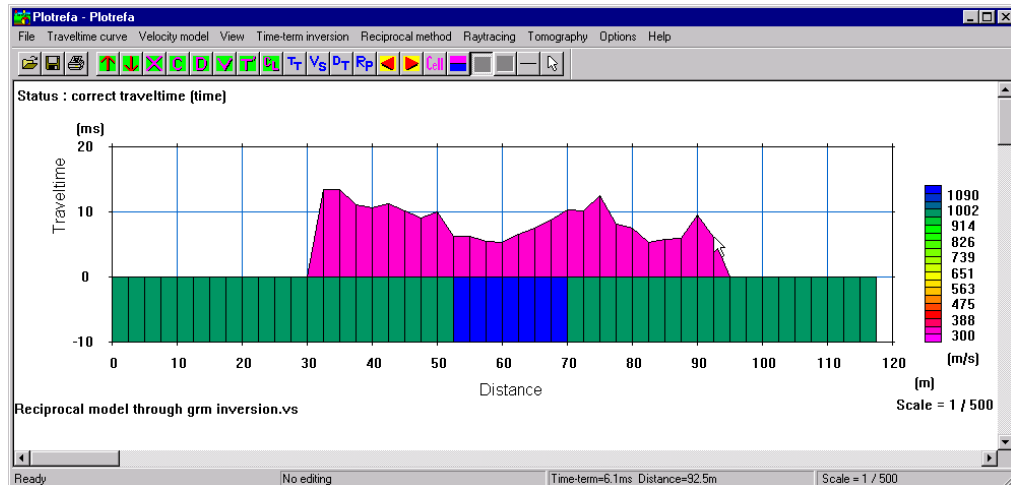

4.6.12 Modify Delay Time (Velocities)

Modifying the velocities in the delay time model is similar to modifying the velocities in the depth model ([Sections 4.3.17 and 4.3.18](#)). Click on “Modify delay time (velocities)”, and you will see the following dialog box:

Enter a velocity value, and then click on the cells you wish that velocity to be assigned to:

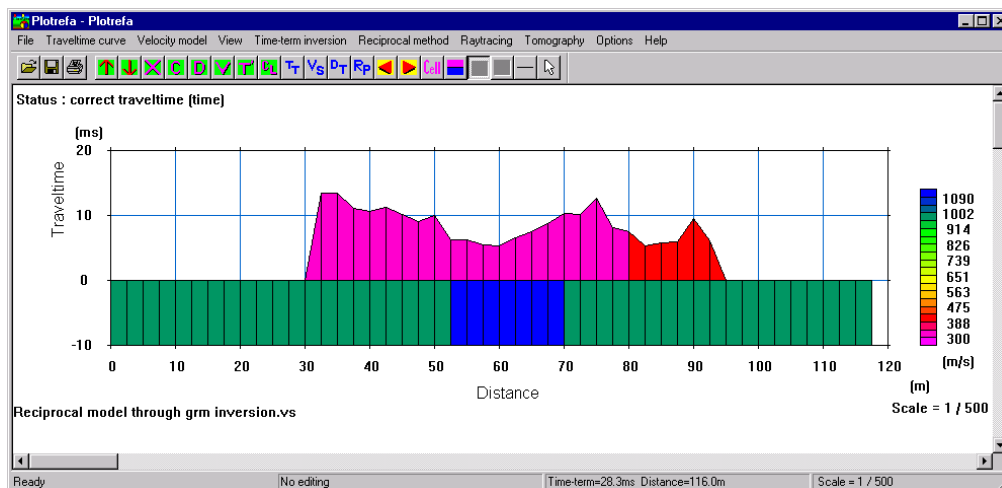

4.6.13 Calculate Velocity Model From Delay Time Data

Once all of the delay times have been determined, you may calculate the velocity model. Click on “Calculate velocity model from delay time data”. You will be presented with the following dialog box:

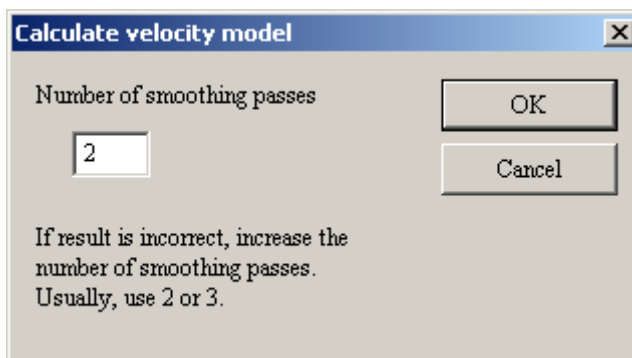

Choose a smoothing level (generally 2 or 3), and press **OK**. The velocity model will be calculated and displayed:

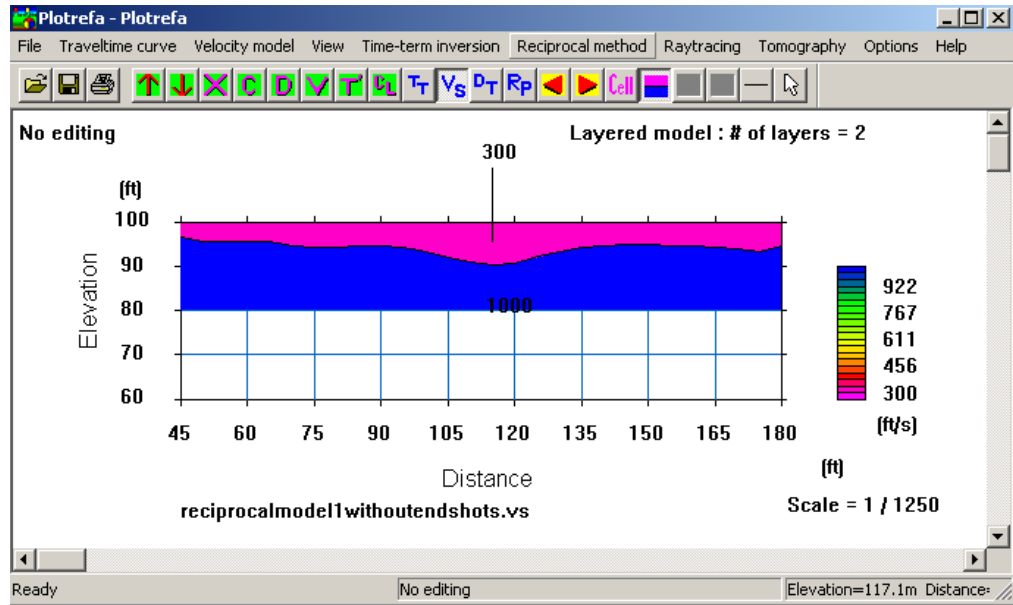

Note that the solution is limited to the zone of refractor overlap (45 to 180 feet). At the beginning of this section, it was noted that in order to calculate a delay time for a refractor at a geophone, a refracted arrival is needed at the geophone from opposing directions. Note that in this data set, the first few arrivals from the end shots are direct arrivals. Hence this condition is not met toward the ends of the geophone spread, and delay times cannot be calculated.

How can we make maximum use of the geophone spread? We must do “offset shots”. The idea of offset shots is to move the shot far enough off the end of the line such that *all* of the first arrivals from that shot are refracted arrivals, including those nearest the shot. The distance from the offset shot to the nearest geophone should be equal to or greater than the crossover distance at that end of the line.

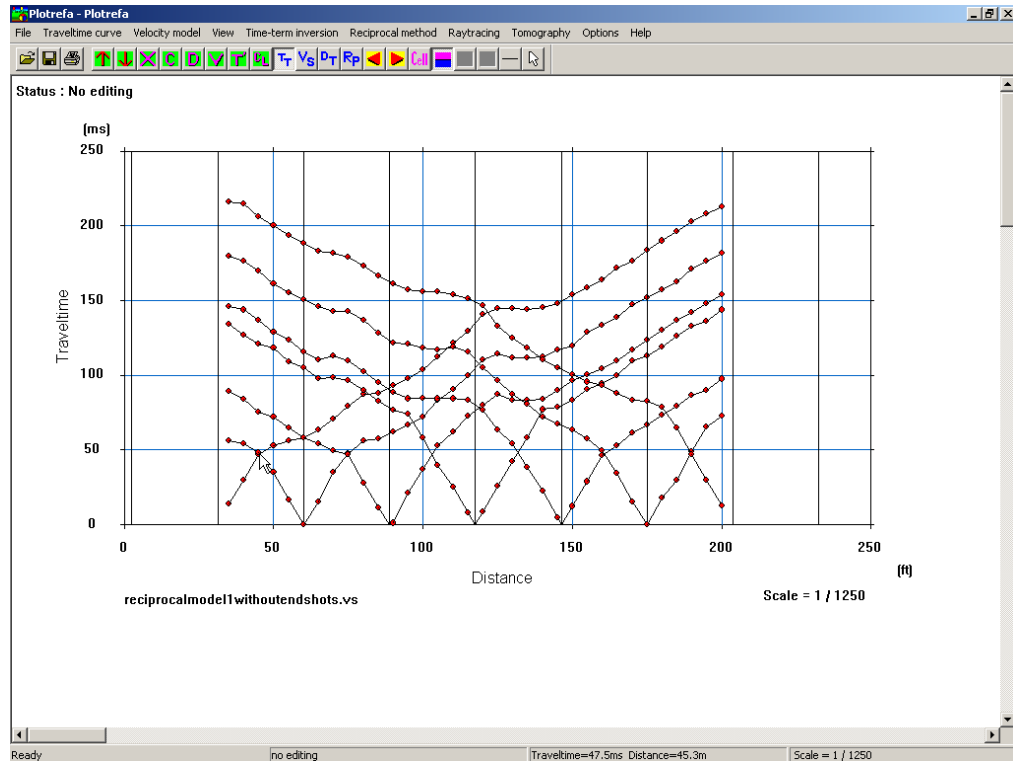

Above is our data set again. The left end-shot is at 31 feet. The crossover distance for that shot is at about the third geophone, or 45 feet. That means the crossover distance is about 15 feet. So we want our offset shot to be at least 15 feet to the left of the left-most geophone (it is generally best to add 50% to account for any deepening of the refractor).

At the right end, the crossover distance is about 25 feet. So we want to do a shot at least 25 feet to the right of the far right geophone.

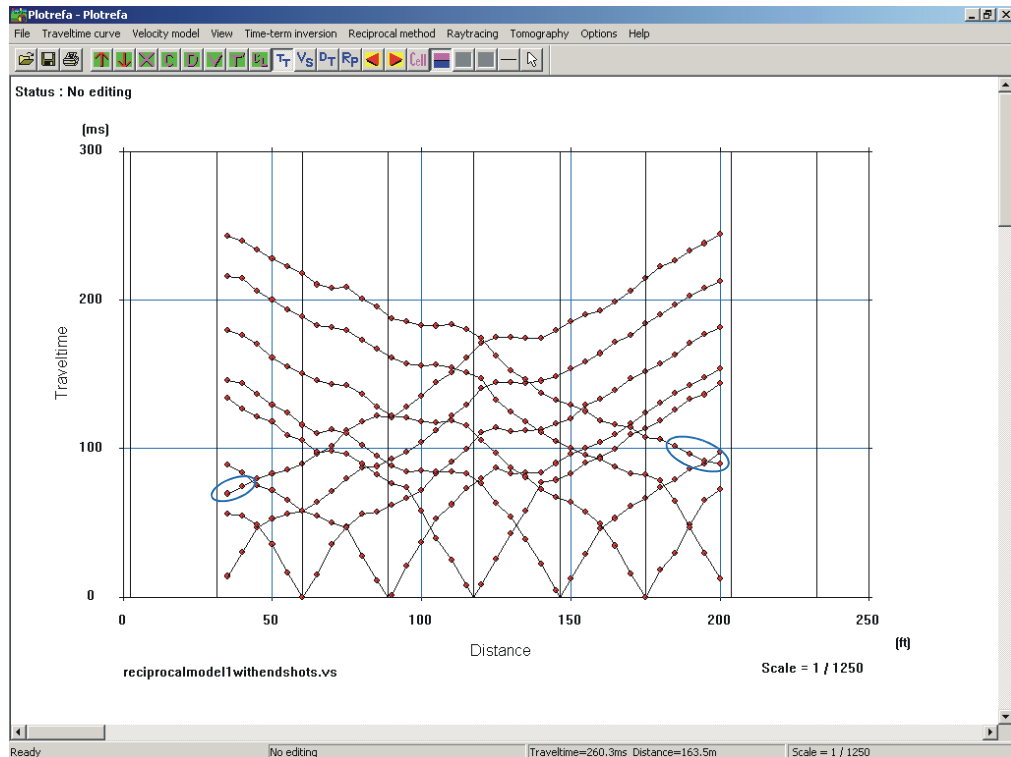

Above is the same data set with the addition of offset shots at 3 feet and 233 feet. The new information gained from the offset shots is indicated. We now have overlap over the entire spread, and can calculate delay times for all 48 geophones for these two shots.

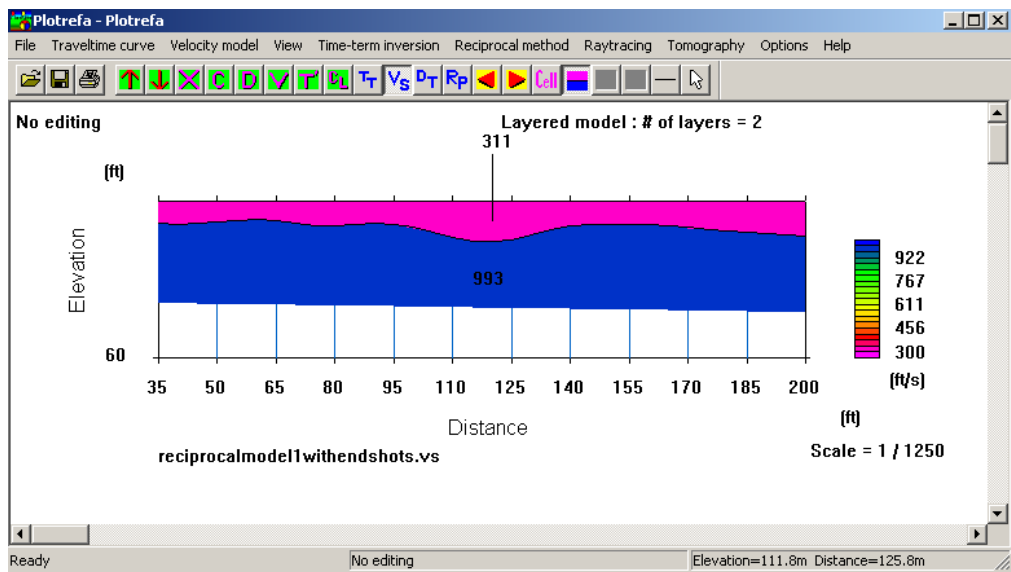

We now have a velocity model that covers the entire geophone spread.

4.7 Raytracing Menu

Click on “Raytracing” to reveal the **Raytracing** menu:

As discussed in earlier sections, Plotrefa may be used to calculate theoretical traveltimes for any velocity model, real or synthetic. This is very useful for pre-survey planning, and for assessing the validity of an interpretation by either the time-term or reciprocal method.

4.7.1 Execute

To calculate the synthetic traveltimes, simply click on “Execute”. The traveltimes will be calculated and displayed along with the observed data, along with the RMS error:

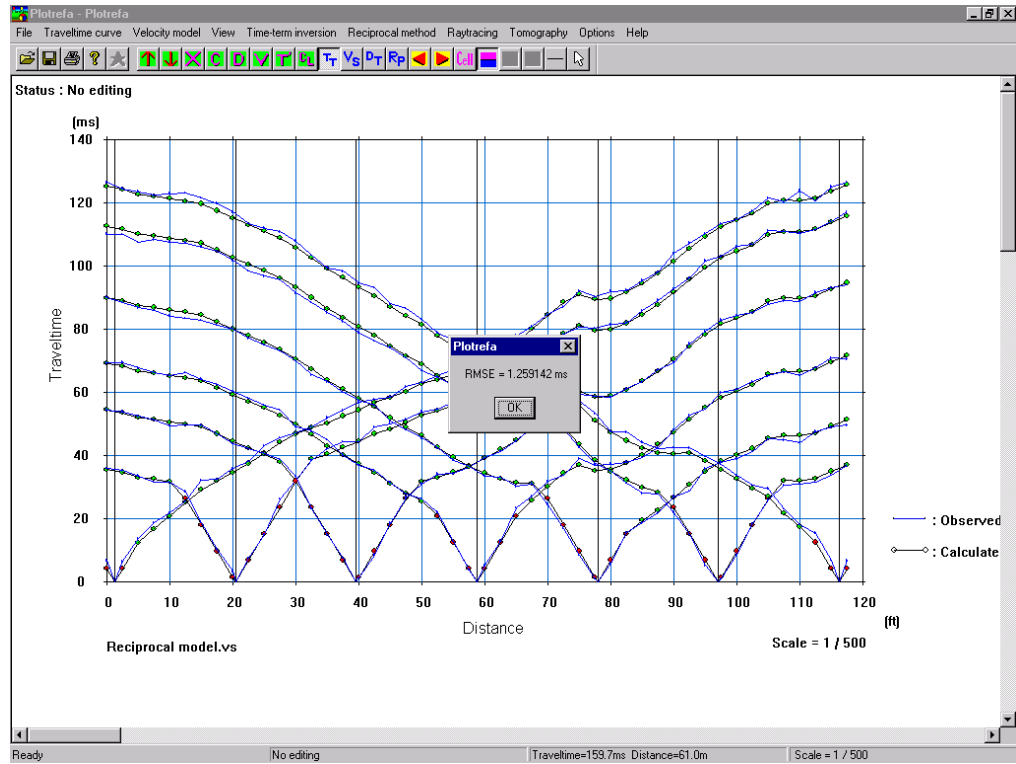

4.7.2 Delete Theoretical Traveltimes

If you would like to delete the theoretical traveltimes, click on “Delete theoretical traveltimes”.

4.7.3 Show RMS Error

If you would like to check the RMS error of the theoretical traveltimes, choose “Show RMS error”:

4.8 Tomography

Click on “Tomography” to reveal the **Tomography** menu:

Tomographic inversion is the third interpretation technique provided by Plotrefa. This method starts with an initial velocity model (generally generated by a time-term inversion), and iteratively traces rays through the model with the goal of minimizing the RMS error between the observed and calculated traveltimes.

Tomographic inversion is generally best used when velocity contrasts are known to be more gradational than discrete, when strong horizontal velocity variations are known to exist, and in extreme topography. All of these cases can lead to erroneous results with the previous two interpretation techniques, depending on the severity.

The typical flow of a tomographic inversion is shown in the flow chart below:

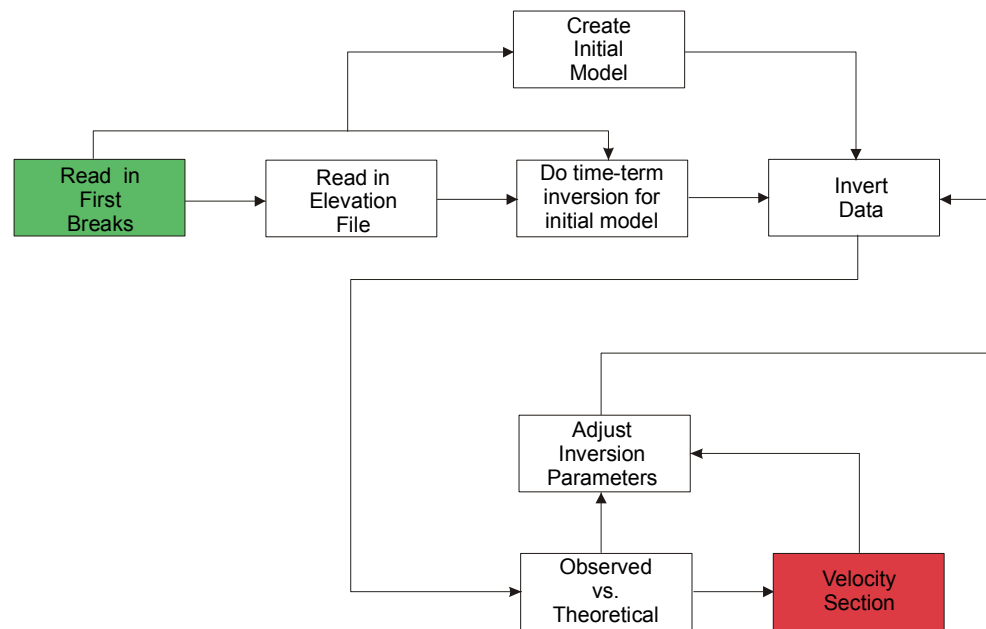

4.8.1 Generate Initial Model

The first step is to create the starting model. Click on “Generate initial model” to reveal the following dialog box:

Initial model for tomography (smooth velocity model)

Use layered model as initial model

Depth to top of lowest layer: 20 ft

Minimum velocity: 300 ft /sec

Maximum velocity: 4000 ft /sec

of layers: 10

Elevation at the bottom left of the model: 59 ft

Elevation at the bottom right of the model: 65 ft

OK

Cancel

The chosen parameters for the initial model should bracket the possibilities. You can get an idea, for instance, of the minimum and maximum velocities from the raw traveltimes curves. From these and crossover distances, an idea of maximum depth of the lowest layer can be estimated.

Note: By far the most important parameters to get right are the minimum and maximum velocities. If these do not bracket the actual velocities, the inversion will not converge. If you are setting these values manually, always err on the conservative side – the maximum velocity can be 20-30% higher than the real maximum, but it should not be lower. Similarly, the minimum velocity can be somewhat lower than the true minimum, but it should not be higher.

In any case, the best way to generate the initial model is to do a quick time-term inversion of the data. Then, open the above dialog box and check the “Use layered model as initial model” checkbox. This overrides all of the other settings in the dialog box, including the minimum and maximum velocities. If you have done a reasonable time-term inversion, the minimum and maximum velocities from this should provide a good tomographic inversion. After doing the inversion, you may change the minimum and

maximum velocities and re-invert if necessary. See the tomography examples in the examples booklet.

Once you have entered the necessary parameters, press **OK**, and you will be presented with the initial velocity model:

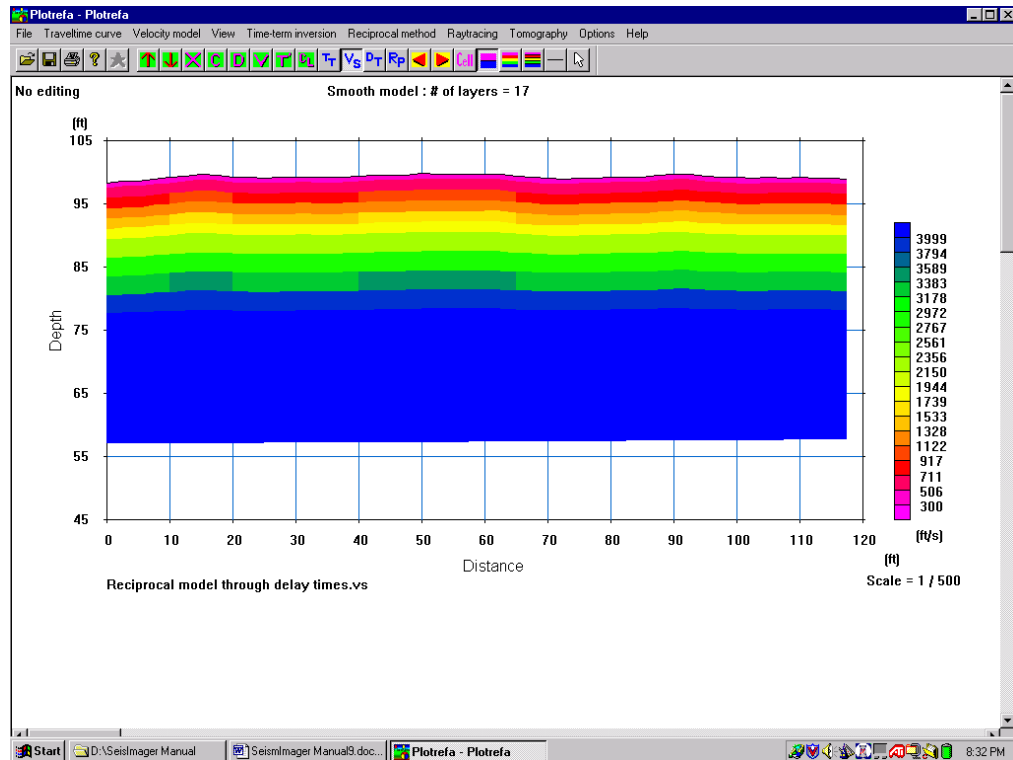

4.8.2 Inversion (With Default Parameters)

You may now conduct the tomographic inversion. If you would like to do so using default inversion parameters, click on “Inversion (with default parameters)”. The inversion will begin. This can take several minutes, depending on the speed of your processor. Progress will be shown in the upper left-hand corner. When the inversion is complete, the velocity model will be displayed:

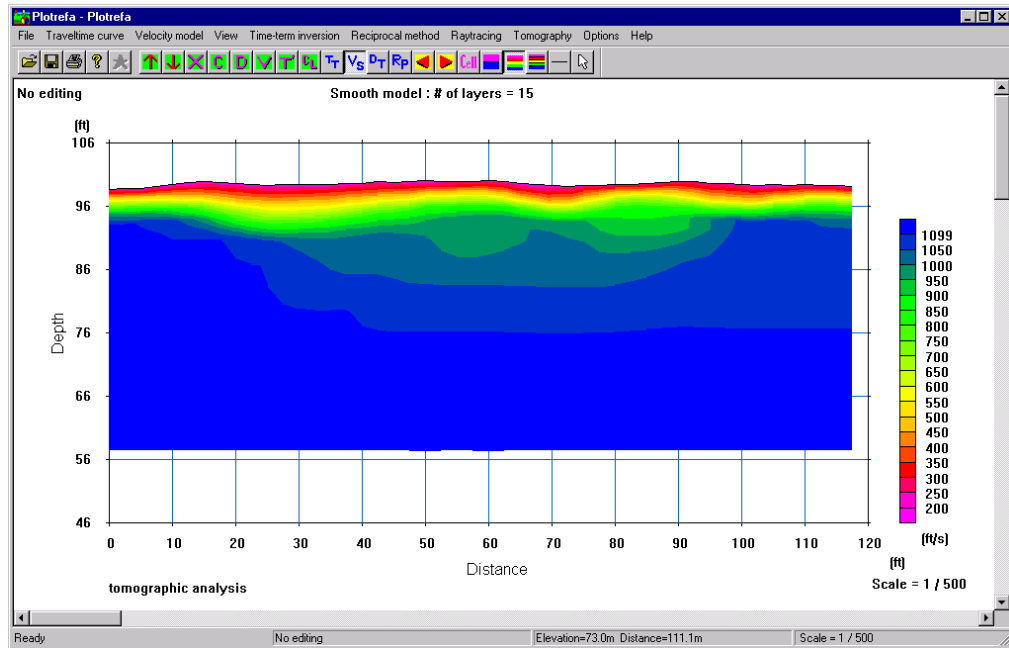

To see the agreement between the calculated and observed data, display the traveltime curves by pressing the  tool button:

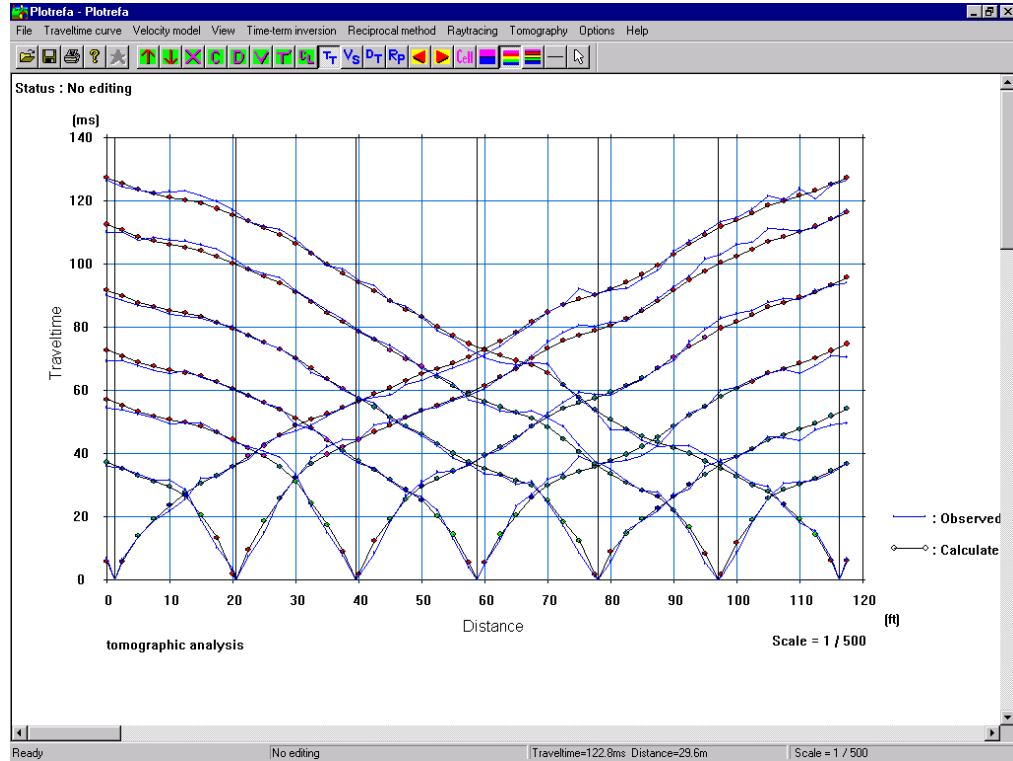

4.8.3 Convert into Layered Model

If you are working in extreme topography, it is often better to use a tomographic approach even in cases of very discrete velocity contrasts. You may then convert the tomogram to a layered model to better represent the layered nature of the geology.

To create a layered model, click on “Convert into layered model”:

Parameter	Value	Unit
# of layers	3	
1st layer velocity	300	ft/sec
2nd layer velocity	1000	ft/sec
3rd layer velocity	2000	ft/sec
4th layer velocity	3000	ft/sec
5th layer velocity	4000	ft/sec
6th layer velocity	5000	ft/sec
7th layer velocity	6000	ft/sec
8th layer velocity	7000	ft/sec
# of smoothing passes	2	

You must provide the number of layers and the velocities you wish them to have. The program will divide the tomogram into the number of layers you specify, and the boundaries between them will divide layers having *bulk* velocities matching the specified velocities. Ideally, if you had done a layered interpretation from the start, this is what it would have looked like.

In the above example, examination of the traveltime curves quickly indicates a two-layer case with approximate velocities of 300 and 1000 feet per second. Entering this information into the above dialog box yields the following:

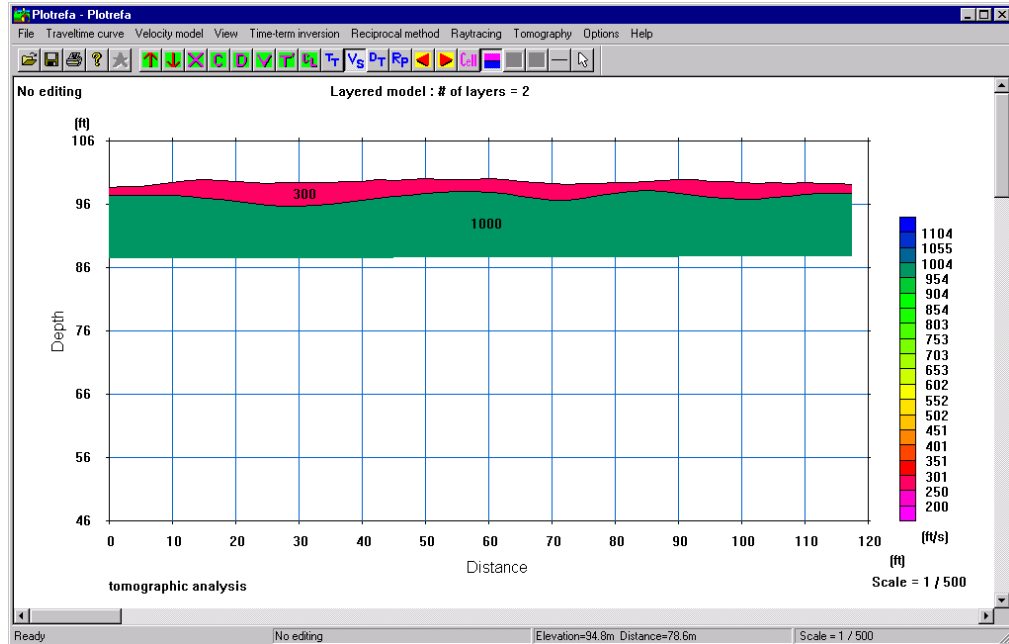

This procedure can be useful in improving the quality of any layered inversion, particularly when layer assignments are difficult. See the examples booklet.

Note: If you wish to keep the tomographic inversion, you must save the Plotrefa file before you convert to a layered model.

4.8.4 Inversion (Set Parameters Manually)

If the tomographic inversion achieved with the default parameters needs improvement, you may modify the tomographic inversion parameters and try again. To do this, click on “Inversion (set parameters manually)”:

Automatic reconstruction

Number of iterations

Option

Number of nodes

Horizontal smoothing

Number of smoothing passes

Smoothing weight (0.3 to 1.00)

Vertical smoothing

Number of smoothing passes

Smoothing weight (0.3 to 1.00)

Number of layers to be smoothed

Minimum velocity ft /sec

Maximum velocity ft /sec

Velocity does not increase with depth

OK

Cancel

Number of iterations: The number of iterations defaults to 10. In general, the better the initial model, the less iterations required to arrive at an acceptable solution. If you are unsure about the quality of the initial model, you might want to compensate by increasing the number of iterations.

Note: the number of iterations setting applies to each inversion, and subsequent inversions are cumulative. For example, if this parameter is set to 10, and after 10 iterations you decide to change one of the inversion parameters and run the inversion again, the cumulative number of inversions will be 20.

Number of nodes: Tomography divides the velocity model into cells of constant velocity, and then traces rays through the model (see Appendix D). The number of nodes defines the density of rays – the more nodes, the more

rays (and the longer the inversion takes). The corner of each cell is a node. In addition, there can be nodes along the sides of each cell. The number of nodes per side is what we refer to when we talk of the number of nodes. In the cell shown below, the number of nodes is one.

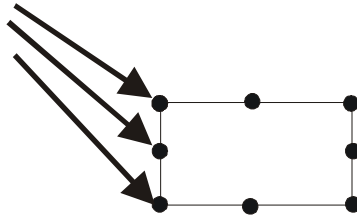

The default value is three, as shown below.

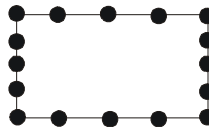

Horizontal/Vertical Smoothing: It is generally desirable to apply some smoothing of the cell velocities, for two reasons: 1) it tends to produce a more pleasing velocity plot, and 2) it removes the inevitable small-scale velocity artifacts that might otherwise be interpreted as real. On the other hand, if you have extremely high-quality, redundant data, you may want to avoid smoothing so as *not* to obscure small-scale variations. In most cases, the default values will be suitable. Smoothing is accomplished by applying a three-term, weighted moving-average filter to the velocity cells. Smoothing in the horizontal and vertical directions is done independently.

Number of smoothing passes: This parameter controls the number of times the weighted average is applied in any one direction. You may run the same filter more than once. The more passes, the more smoothing.

Smoothing weight: This is the weight of the center term in the moving average. The basic filter equation is as follows:

$$V_2 = W_1V_1 + W_2V_2 + W_3V_3$$

where $W_1=W_3$ and $W_1+W_2+W_3 = 1$.

The default value of 0.5 for W_2 therefore weights the center term twice as much as the other two.

Note: The larger the smoothing weight, the less the model will be smoothed. A smoothing weight of one will result in no smoothing at all. You may set the number of smoothing passes to zero if you wish not to smooth the model.

Number of layers to be smoothed: This applies to vertical smoothing only. Since the resolving capabilities of any geophysical technique, including seismic tomography, tend to decrease with depth, it is often desirable to smooth the bottom layers more than the top layers. This parameter determines the number of layers *from the bottom* of the model to be smoothed. For instance, if the tomogram has 15 layers, setting this parameter to five will result in the bottom five layers being smoothed.

Minimum/maximum velocity: See above for explanation. If the match between observed and calculated data is poor, it may be that the minimum and maximum velocities need to be decreased and increased, respectively. You may change them in this dialog box and do the inversion again.

Note: If you used the time-term model as your initial model, the minimum and maximum velocities in this dialog box will match those of the time-term inversion until you override them.

Velocity vs. depth: In any surface refraction inversion technique, including tomography, it must be assumed that velocity increases with depth. However, this is not true in surface-to-borehole and borehole-to-borehole tomographic surveys. If you are doing a borehole survey, de-select “Velocity does not increase with depth”.

Note: If you de-select the above parameter, run an inversion, and then decide to run a second inversion, be sure to de-select the parameter again, as it is selected by default.

4.9 *Options Menu*

Click on “Options” to reveal the **Options** menu:

4.9.1 **Dimension size**

You must make sure that the program is dimensioned large enough for the data set you are working with. Setting the values too small will result in errors. On the other hand, it is best not to set them much bigger than you really need, because memory is set aside to accommodate these dimensions. It is best to set them large enough, but not much larger than required.

Note: In order for changes to become effective, you must check the “Change dimension size” checkbox.

Note: The maximum allowable dimensions are displayed, and are a function of which version of SeisImager/2D you purchased. If you choose to upgrade, we can provide a password that will increase the maximum dimension sizes.

4.9.2 Units [

Click on the units you would like shown on your travelttime plots and velocity sections.

4.9.3 Edit Title

Clicking on “Edit title” will reveal the following dialog box:



Enter the title you wish to have displayed on your output, and press **OK**.

4.10 Additional Tool Buttons

4.10.1 Scroll Tool Buttons:

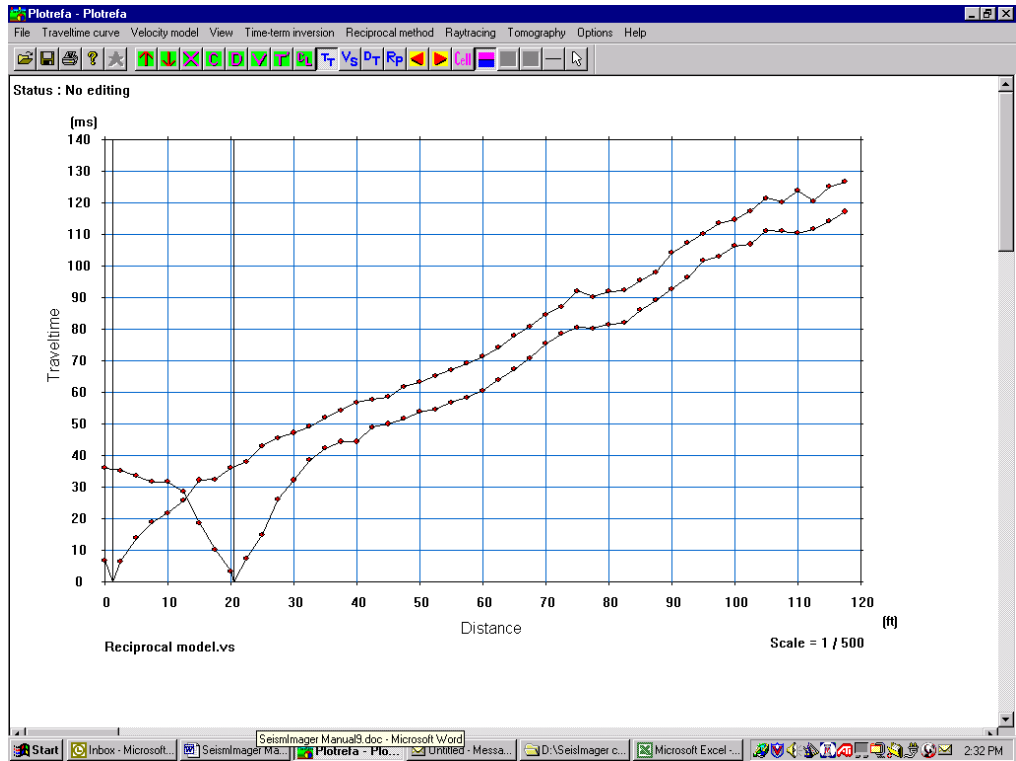
If you have numerous shots in a spread, you may find it convenient to only display a subset of them at any given time. As explained in the [Section 4.4.1](#), you can control the number of shots displayed in the **Axis configuration (manual)** sub-menu. Using our data set as an example, we will show only two travelttime curves at a time:

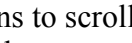

The left-most two shots (“shot one” and “shot two”) are displayed. We may now use the  buttons to scroll through the spread. Pressing the  button once will display shots two and three:

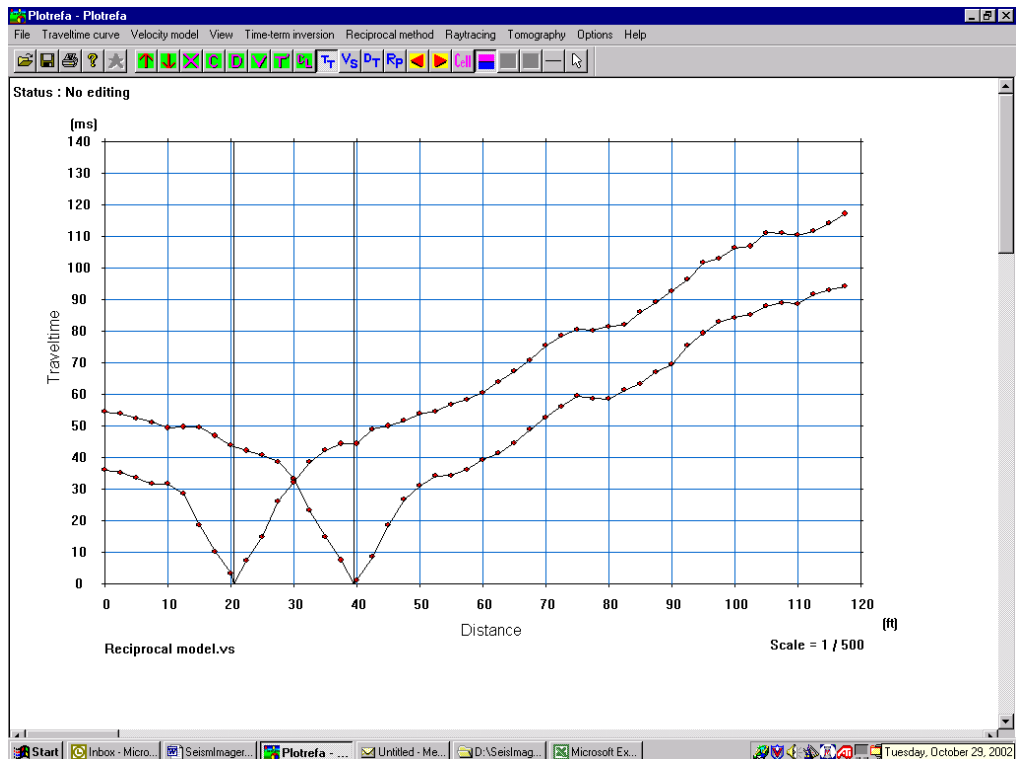

The number of shots added or removed with each press of the button is always one less than the total number of shots displayed. If we display three shots at a time, as shown below,

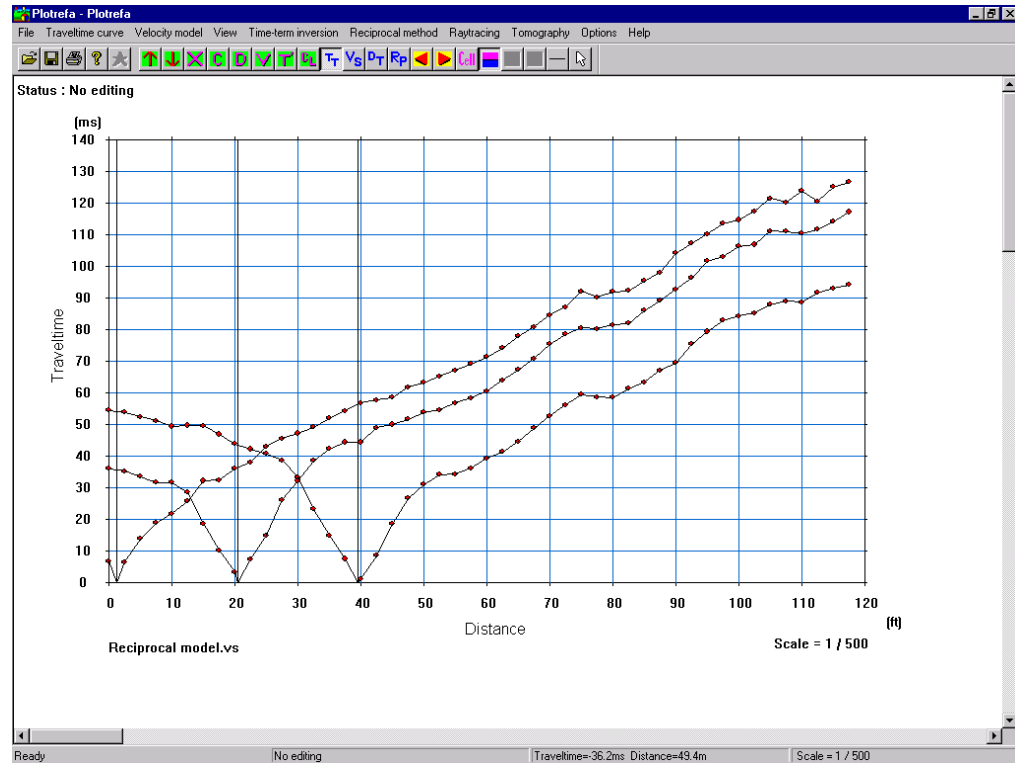

pressing the button once will result in shots 3, 4, and 5 being displayed:

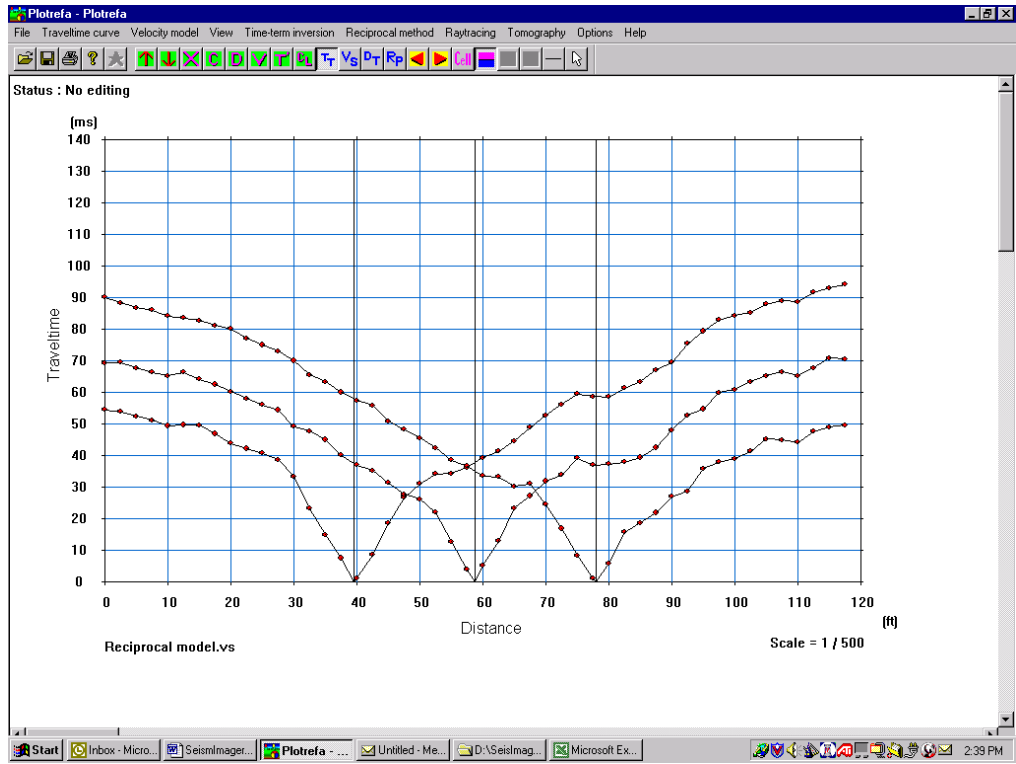

5 Appendices

5.1 **Appendix A - Fundamentals of Seismic Refraction**

A simple two-layer velocity model along with its associated travelttime curve is shown below. We will use this figure as a basis for discussing the fundamental principals underlying the seismic refraction technique.

Note: This appendix discusses the very basics of seismic refraction, and is not intended to be a complete treatment of the subject. For more in-depth discussions, see the recommended reading list in Appendix E.

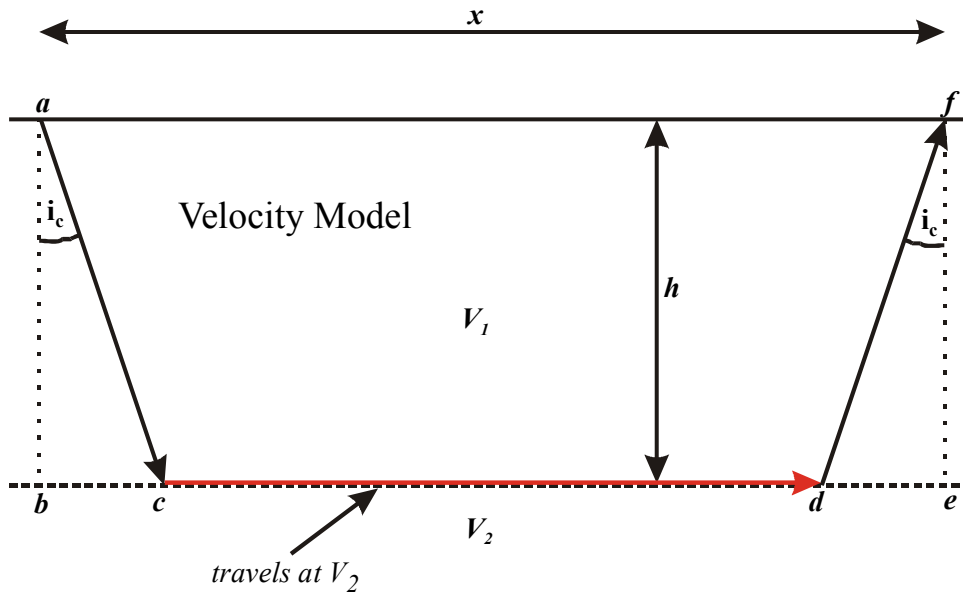
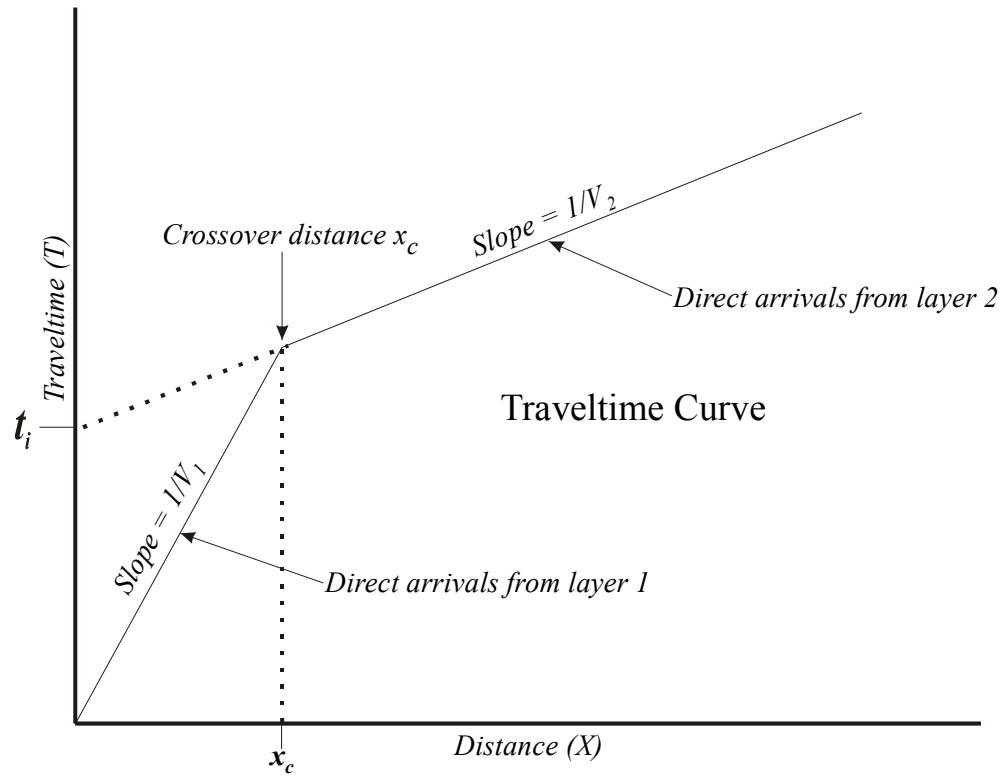

The break in slope of the above traveltime curve, which occurs at the “crossover distance”, marks the point at which traveltimes refracted from V_2 overtake direct arrivals traveling through V_1 . The equation for the first segment T_1 is simply

$$T_1 = X / V_1$$

(Equation 5.1-1)

The equation for T_2 is

$$T_2 = \frac{\overline{ac}}{V_1} + \frac{\overline{cd}}{V_2} + \frac{\overline{df}}{V_1}$$

From the figure above,

$$\overline{ac} = \overline{df} = h \cos(i_c)$$

Substituting, we get

$$T_2 = \frac{2h}{V_1 \cos(i_c)} + \frac{\overline{cd}}{V_2}$$

(Equation 5.1-2)

Now,

$$\tan(i_c) = \frac{\overline{bc}}{h} = \frac{\overline{de}}{h}$$

or

$$\overline{bc} = \overline{de} = h \tan(i_c).$$

Referring back to the figure,

$$cd = x - bc - dc = x - 2h \tan(i_c)$$

Substituting into Equation 5.1-2,

$$T_2 = \frac{2h}{V_1 \cos(i_c)} + \frac{x - 2h \tan(i_c)}{V_2}$$

(Equation 5.1-3)

Rearranging,

$$T_2 = \frac{2h}{V_1 \cos(i_c)} - \frac{2h \tan(i_c)}{V_2} + \frac{x}{V_2}$$

$$T_2 = 2h \left\{ \frac{1}{V_1 \cos(i_c)} - \frac{\tan(i_c)}{V_2} \right\} + \frac{x}{V_2}$$

Substituting $\sin(i_c)/\cos(i_c)$ for $\tan(i_c)$,

$$T_2 = 2h \left\{ \frac{1}{V_1 \cos(i_c)} - \frac{\sin(i_c)}{V_2 \cos(i_c)} \right\} + \frac{x}{V_2}$$

Rearranging,

$$T_2 = 2h \left\{ \frac{V_2}{V_1 V_2 \cos(i_c)} - \frac{V_1 \sin(i_c)}{V_1 V_2 \cos(i_c)} \right\} + \frac{x}{V_2}$$

$$T_2 = 2h \left\{ \frac{V_2 - V_1 \sin(i_c)}{V_1 V_2 \cos(i_c)} \right\} + \frac{x}{V_2}$$

Equation 5.1-4

From Snell's Law,

$$\sin(i_c) = \frac{V_1}{V_2}$$

Equation 5.1-5

Substituting $V_1/\sin(i_c)$ for the V_2 term in the numerator of Equation 5.1-4,

$$T_2 = 2h \left\{ \frac{V_1 / \sin(i_c) - V_1 \sin(i_c)}{V_1 V_2 \cos(i_c)} \right\} + \frac{x}{V_2}$$

$$T_2 = 2hV_1 \left\{ \frac{1 / \sin(i_c) - \sin(i_c)}{V_1 V_2 \cos(i_c)} \right\} + \frac{x}{V_2}$$

$$T_2 = 2h \left\{ \frac{1 / \sin(i_c) - \sin(i_c)}{V_2 \cos(i_c)} \right\} + \frac{x}{V_2}$$

$$T_2 = 2h \left\{ \frac{1 - \sin^2(i_c) / \sin(i_c)}{V_2 \cos(i_c)} \right\} + \frac{x}{V_2}$$

$$T_2 = 2h \left\{ \frac{1 - \sin^2(i_c)}{V_2 \sin(i_c) \cos(i_c)} \right\} + \frac{x}{V_2}$$

since $1 - \sin^2(i_c) = \cos^2(i_c)$,

$$T_2 = 2h \left\{ \frac{\cos^2(i_c)}{V_2 \sin(i_c) \cos(i_c)} \right\} + \frac{x}{V_2}$$

$$T_2 = 2h \frac{\cos(i_c)}{V_2 \sin(i_c)} + \frac{x}{V_2}$$

and from Snell's Law (Equation 5.1-5), we substitute V_1 for $V_2 \sin(i_c)$:

$$T_2 = 2h \frac{\cos(i_c)}{V_1} + \frac{x}{V_2}$$

Equation 5.1-6

since

$$\cos(i_c) = \sqrt{1 - \sin^2(i_c)},$$

substituting into Equation 5.1-6 gives us

$$T_2 = 2h \frac{\sqrt{1 - \sin^2(i_c)}}{V_1} + \frac{x}{V_2}$$

Equation 5.1-7

From Snell's Law (Equation 5.1-5),

$$\sin(i_c) = \frac{V_1}{V_2}$$

so

$$\sin^2(i_c) = \left(\frac{V_1}{V_2}\right)^2$$

Substituting back into Equation 5.1-7,

$$T_2 = 2h \frac{\sqrt{1 - \left(\frac{V_1}{V_2}\right)^2}}{V_1} + \frac{x}{V_2}$$

$$T_2 = 2h \frac{\sqrt{1 - \frac{V_1^2}{V_2^2}}}{V_1} + \frac{x}{V_2}$$

$$T_2 = 2h \frac{\sqrt{\frac{V_2^2 - V_1^2}{V_2^2}}}{V_1} + \frac{x}{V_2}$$

$$T_2 = 2h \frac{\left(\frac{\sqrt{V_2^2 - V_1^2}}{V_2}\right)}{V_1} + \frac{x}{V_2}$$

$$T_2 = 2h \frac{\sqrt{V_2^2 - V_1^2}}{V_1 V_2} + \frac{x}{V_2}$$

For the special case of $x = 0$, we get

$$T_i = \frac{2h\sqrt{V_2^2 - V_1^2}}{V_1 V_2}$$

Equation 5.1-8

or, using Equation 5.1-6,

$$T_i = \frac{2h \cos(i_c)}{V_1}$$

Equation 5.1-9

T_i is called the “intercept time”.

From Snell’s Law (Equation 5.1-5),

$$i_c = \sin^{-1} \frac{V_1}{V_2}$$

Solving Equation 5.1-9 for h and substituting,

$$h = \frac{1}{2} \frac{T_i V_1}{\cos(\sin^{-1} V_1 / V_2)}$$

Equation 5.1-10

Alternatively, solving Equation 5.1-8 for h yields

$$h = \frac{1}{2} \frac{T_i V_1 V_2}{\sqrt{V_2^2 - V_1^2}}$$

Equation 5.1-11

Using Equations 5.1-10 or 5.1-11, we can calculate the depth by measuring T_i , V_1 , and V_2 from the travelttime graph.

Alternatively, the crossover distance can be used in lieu of the intercept time. At the crossover distance x_c , $T_1 = T_2$, so we can equate Equations 5.1-1 and 5.1-8:

$$T_1 = \frac{x_c}{V_1} = \frac{2h\sqrt{V_2^2 - V_1^2}}{V_1 V_2} + \frac{x_c}{V_2} = T_2$$

$$\frac{x_c}{V_1} - \frac{x_c}{V_2} = \frac{2h\sqrt{V_2^2 - V_1^2}}{V_1 V_2}$$

$$\frac{x_c}{2h} \left(\frac{1}{V_1} - \frac{1}{V_2} \right) = \frac{\sqrt{V_2^2 - V_1^2}}{V_1 V_2}$$

$$\frac{x_c}{2h} = \frac{\frac{\sqrt{V_2^2 - V_1^2}}{V_1 V_2}}{\left(\frac{1}{V_1} - \frac{1}{V_2} \right)}$$

$$h = \frac{1}{2} \frac{\left(\frac{1}{V_1} - \frac{1}{V_2} \right)}{\frac{\sqrt{V_2^2 - V_1^2}}{V_1 V_2}} x_c$$

$$h = \frac{1}{2} \frac{\left(\frac{1}{V_1} - \frac{1}{V_2} \right) V_1 V_2}{\sqrt{V_2^2 - V_1^2}} x_c$$

$$h = \frac{1}{2} \frac{\left(\frac{V_2}{V_1 V_2} - \frac{V_1}{V_1 V_2} \right) V_1 V_2}{\sqrt{V_2^2 - V_1^2}} x_c$$

$$h = \frac{1}{2} \frac{\left(\frac{V_2 - V_1}{V_1 V_2} \right) V_1 V_2}{\sqrt{V_2^2 - V_1^2}} x_c$$

$$h = \frac{1}{2} \frac{(V_2 - V_1)}{\sqrt{V_2^2 - V_1^2}} x_c$$

Squaring both sides,

$$h^2 = \frac{1}{4} \frac{(V_2 - V_1)^2}{V_2^2 - V_1^2} x_c^2$$

Now, $V_2^2 - V_1^2$ can be factored into

$$(V_2 + V_1)(V_2 - V_1)$$

Substituting,

$$h^2 = \frac{1}{4} \frac{(V_2 - V_1)^2}{(V_2 + V_1)(V_2 - V_1)} x_c^2$$

$$h^2 = \frac{1}{4} \frac{(V_2 - V_1)}{(V_2 + V_1)} x_c^2$$

$$h = \frac{1}{2} \sqrt{\frac{(V_2 - V_1)}{(V_2 + V_1)}} x_c$$

Equation 5.1-12

Equations 5.1.11 and 5.1.12 are the most basic equations in seismic refraction, relating layer thickness to the travelttime curve. Although valid only for constant layer thickness, understanding them and where they came from are essential to understanding seismic refraction in general. The above can be extended to any number of layers. See [Repath \(1973\)](#) for a good example of a four-layer case.

The derivation for a smoothly varying thickness with flat interfaces is much more complex, and beyond the scope of this discussion. A good treatment of the varying thickness case is also provided in the above-mentioned reference.

5.2 Appendix B - The Time-term Method

The time-term technique is a linear Least-Squares approach to determining the best discrete-layer solution to the data. The math behind this technique is comparatively simple. Referring to the figure below,

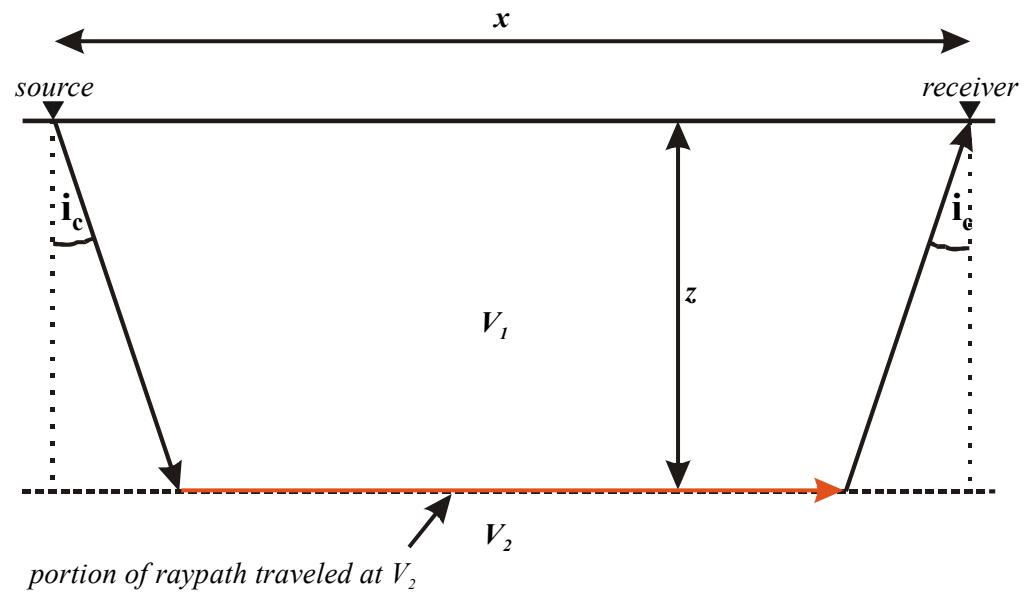

we define the “slowness” S as the inverse velocity:

$$S_1 = \frac{1}{V_1}$$

$$S_2 = \frac{1}{V_2}$$

From Snell's Law,

$$\sin(i_c) = \frac{S_2}{S_1}$$

Referring back to the derivation in Appendix A (see math leading up to Equation 5.1-6), the total travelttime t from source to receiver is then

$$t = 2S_1 \cos(i_c)z + xS_2$$

Now, if we define

$$c = 2S_1 \cos(i_c),$$

then

$$t = 2cz + xS_2.$$

And z and S_2 are unknown.

The above example assumes that the refractor is parallel to the ground surface. If we expand this to the general case – non-parallel, curved surfaces, as shown below – we end up with three unknowns rather than two, e.g. z_1 , z_2 and S_2 .

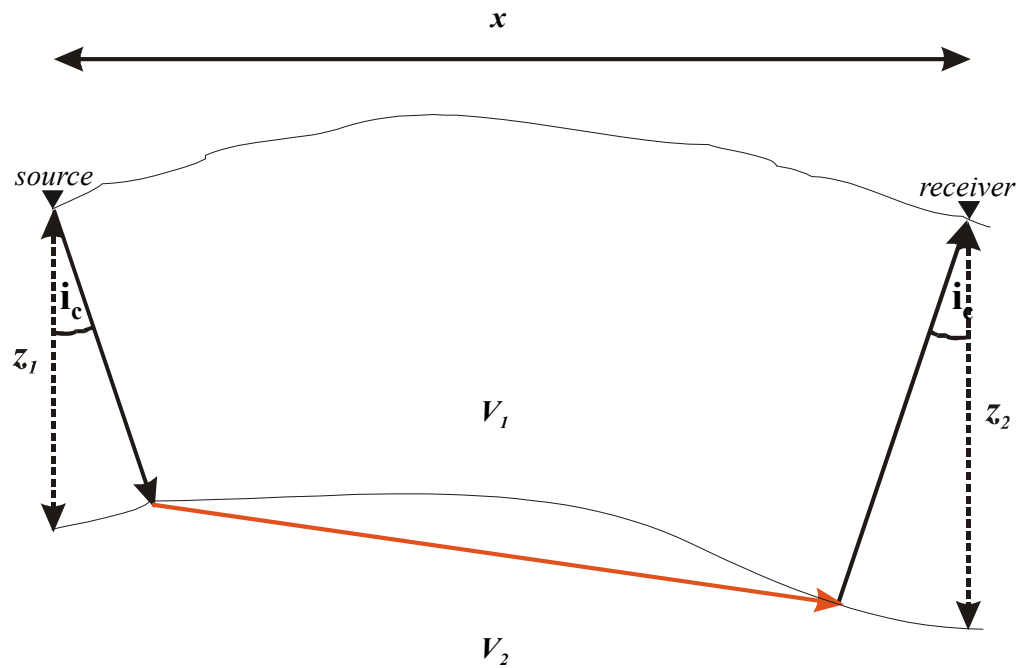

Now, we have

$$t = cz_1 + cz_2 + xS_2 .$$

Generalizing, we get

$$t_j = \sum_{k=1}^n c_{jk} z_k + x_j S_2$$

In matrix form, we get

$$\begin{pmatrix} c_{11} & c_{12} & c_{13} & \cdot & c_{1n} & x_1 \\ c_{21} & c_{22} & c_{23} & \cdot & c_{2n} & x_2 \\ c_{31} & c_{32} & c_{33} & \cdot & c_{3n} & x_3 \\ c_{41} & c_{42} & c_{43} & \cdot & c_{4n} & x_4 \\ \cdot & \cdot & \cdot & \cdot & \cdot & \cdot \\ c_{m1} & c_{m2} & c_{m3} & \cdot & c_{mn} & x_m \end{pmatrix} \begin{pmatrix} z_1 \\ z_2 \\ z_3 \\ \cdot \\ z_n \\ S_2 \end{pmatrix} = \begin{pmatrix} t_1 \\ t_2 \\ t_3 \\ t_4 \\ \cdot \\ t_m \end{pmatrix}$$

where m = number of traveltimes, and n = number of receivers (depths to be calculated). We can now solve the matrix for $z_1 \dots z_n$ and S_2 .

5.3 Appendix C - The Reciprocal Time Method

The reciprocal time method is a much more “hands on” approach than the time-term method. Fewer assumptions are made, and the interpreter interacts with the software to a much greater degree, providing much more input. Generally, the reciprocal method should be used when the desired result needs to be as detailed as possible. Read Palmer (1980) for a complete treatment of the reciprocal method.

The reciprocal method generally requires more data because of its use of “delay times”, which require a refracted arrival from each direction (see [Section 4.6](#)). Ideally, data is acquired such that a delay time can be computed beneath each geophone. The depth is then computed from the delay time and the velocity.

Delay Time

We will now introduce the concept of the delay time.

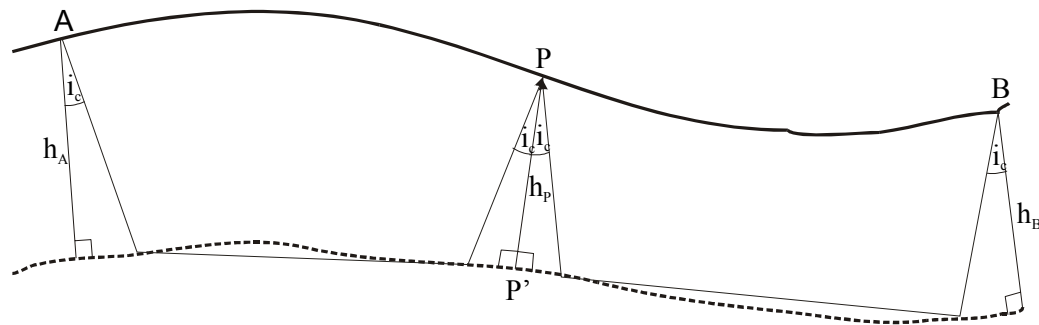

Referring to the figure above, and following the derivation of Equation 5.1-6 in Appendix A,

$$T_2 = 2h \frac{\cos(i_c)}{V_1} + \frac{x}{V_2}$$

it is easy to show that

$$T_{AB} \cong \frac{h_A \cos(i_c)}{V_1} + \frac{\overline{AB}}{V_2} + \frac{h_B \cos(i_c)}{V_1}$$

Similarly,

$$T_{AP} \cong \frac{h_A \cos(i_c)}{V_1} + \frac{\overline{AP}}{V_2} + \frac{h_P \cos(i_c)}{V_1}$$

and

$$T_{BP} \cong \frac{h_B \cos(i_c)}{V_1} + \frac{\overline{BP}}{V_2} + \frac{h_P \cos(i_c)}{V_1}$$

We define

$$t_0 = T_{AP} + T_{BP} - T_{AB}$$

Equation 5.3-1

Substituting,

$$t_0 = \left\{ \frac{h_A \cos(i_c)}{V_1} + \frac{\overline{AP}}{V_2} + \frac{h_P \cos(i_c)}{V_1} \right\} + \left\{ \frac{h_B \cos(i_c)}{V_1} + \frac{\overline{BP}}{V_2} + \frac{h_P \cos(i_c)}{V_1} \right\} \\ - \left\{ \frac{h_A \cos(i_c)}{V_1} + \frac{\overline{AB}}{V_2} + \frac{h_B \cos(i_c)}{V_1} \right\}$$

or

$$t_0 = \frac{\overline{AP}}{V_2} + \frac{\overline{BP}}{V_2} + \frac{\overline{AB}}{V_2} + \frac{2h_P \cos(i_c)}{V_1}$$

referring to the figure, we see that

$$\overline{AB} = \overline{AP} + \overline{BP}.$$

Substituting,

$$t_0 = \frac{2h_P \cos(i_c)}{V_1}$$

t_0 is twice the time required for the seismic energy to travel from P to P'. We call $t_0/2$ the "delay time":

Delay time D_T at point $P =$

$$D_T = \frac{t_0}{2} = \frac{h_P \cos(i_c)}{V_1}$$

Equation 5.3-2

Reduced Traveltimes

We will now examine the concept of “reduced traveltimes”. Computing reduced traveltimes is useful because it tends to remove the effect of changing layer thickness on the traveltimes curve, and allows a better measurement of velocity. As will be seen, it also allows the computation of delay time and hence, refractor depth.

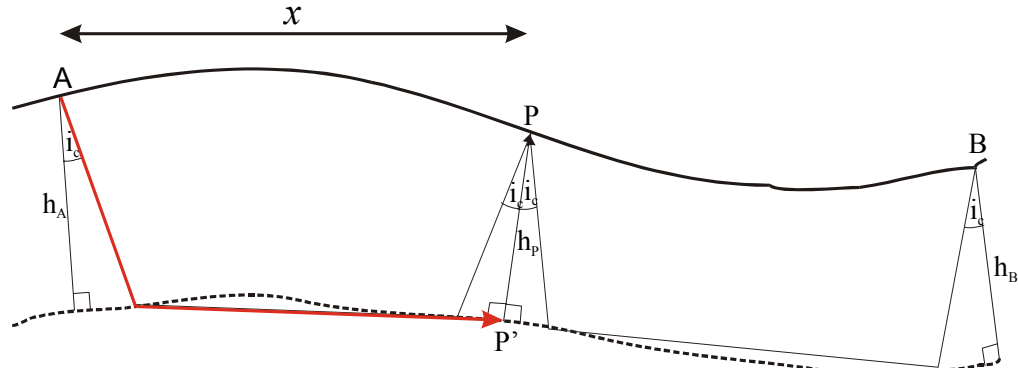

Referring to the above figure, we define T'_{AP} (the reduced traveltime at point P for a source at A) as $T_{AP'}$. This is represented by the red arrow. Upon examination, it should be apparent that a plot of T' vs. x , since all that changes with the position of P is the length of the ray traveling at V_2 , will be roughly linear, unaffected by changes in thickness of the layer. Further, its slope will be $1/V_2$.

Mathematically, $T_{AP'}$ can be expressed as follows:

$$T'_{AP} = T_{AP'} = T_{AP} - \frac{t_0}{2}$$

From Equation 5.3-1, we see that

$$T'_{AP} = T_{AP} - \frac{(T_{AP} + T_{BP} - T_{AB})}{2}$$

Equation 5.3-3

Rearranging, we get

$$T'_{AP} = \frac{T_{AB}}{2} + \frac{(T_{AP} - T_{BP})}{2}$$

Equation 5.3-4

The above equation allows a graphical determination of the T' curve. Refer to the figure below.

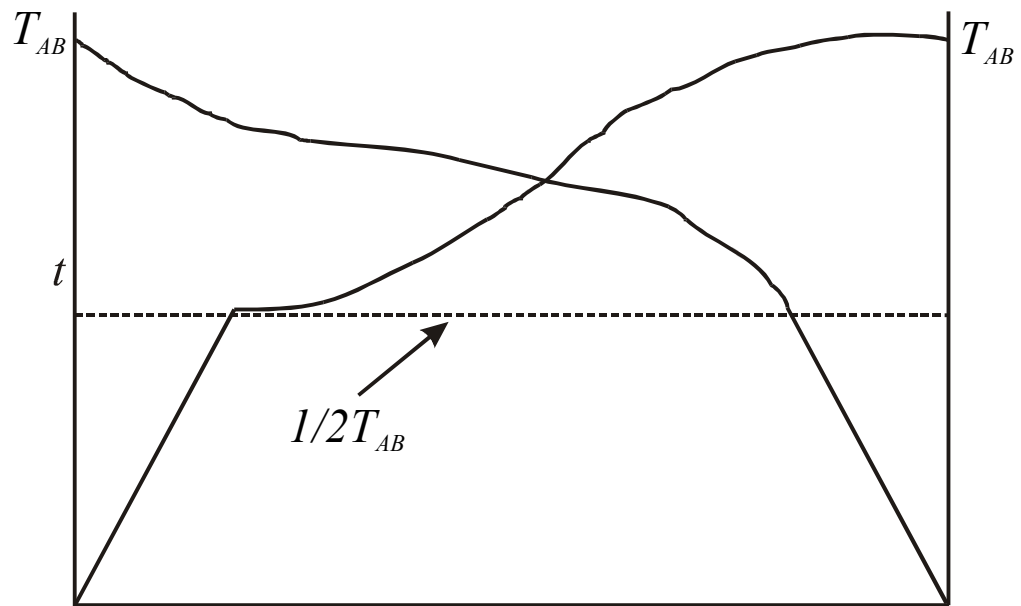

The traveltime curves represent what you would expect to see from a velocity structure in which the thickness of layer 1 varies with x . T_{AB} is known as the “reciprocal time”. We have drawn in $1/2 T_{AB}$, which is the first term in Equation 5.3-4.

The second term,

$$\frac{(T_{AP} - T_{BP})}{2},$$

Can also be determined graphically, as shown below.

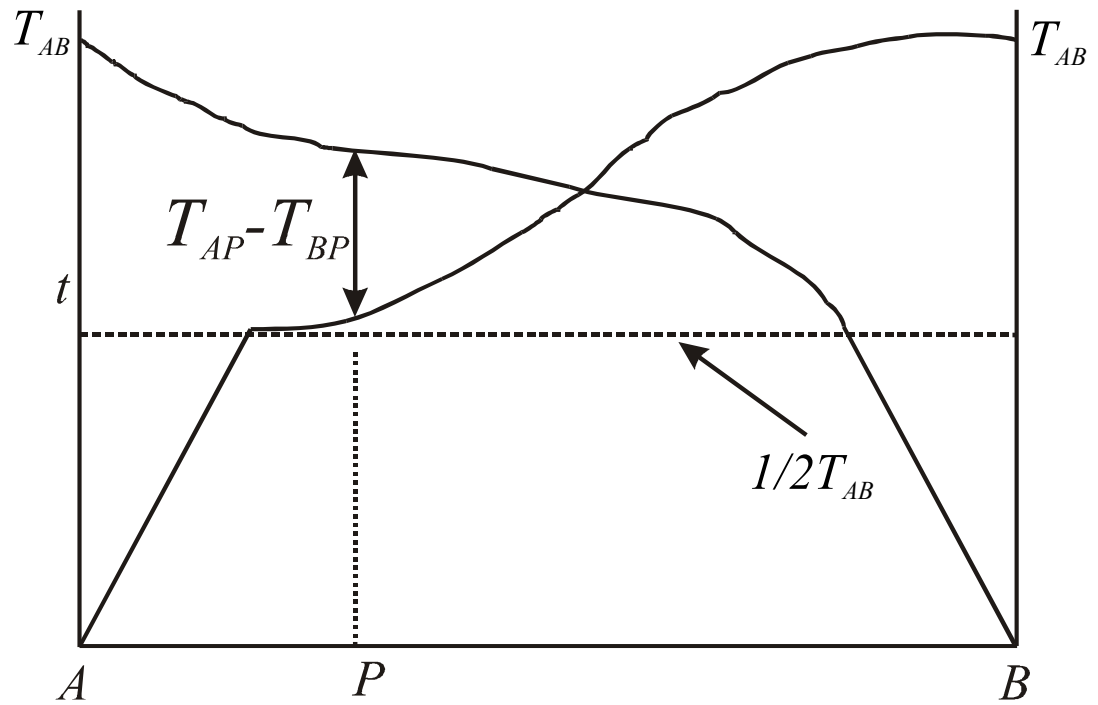

Now, using Equation 5.3-4, we can draw the reduced traveltime curve by adding $T_{AP} - T_{BP}/2$ to the $T_{AB}/2$ line:

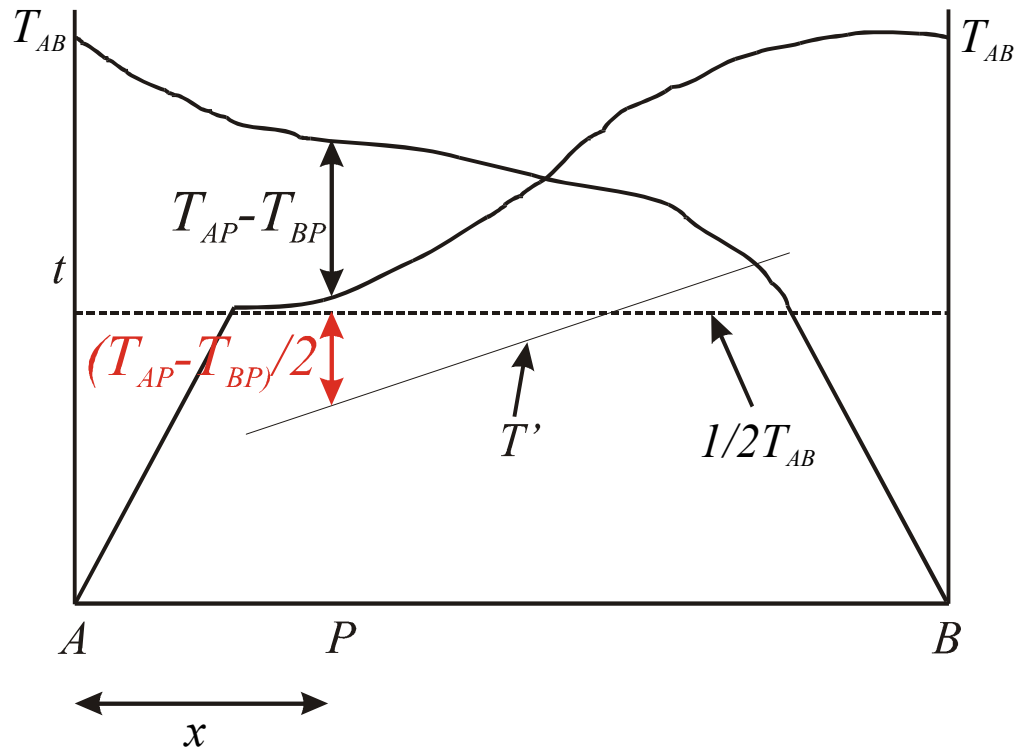

The slope of T' is $1/V_2$.

Delay Time

We now have everything we need to calculate the delay time at point P .
Combining Equations 5.3-1

$$t_0 = T_{AP} + T_{BP} - T_{AB}$$

and 5.3-3

$$T'_{AP} = T_{AP} - \frac{(T_{AP} + T_{BP} - T_{AB})}{2}$$

We see that

$$T'_{AP} = T_{AP} - \frac{t_0}{2}$$

Combining with Equation 5.3-2

$$\frac{t_0}{2} = \frac{h_P \cos(i_c)}{V_1}$$

we get

$$T'_{AP} = T_{AP} - \frac{h_P \cos(i_c)}{V_1}$$

Equation 5.3-5

From Equation 5.1-6, it is fair to say that

$$T_{AP} \cong \frac{2h_P \cos(i_c)}{V_1} + \frac{x}{V_2}$$

Equation 5.3-6

Combining Equations 5.3-5 and 5.3-6 gives

$$T'_{AP} = \frac{h_P \cos(i_c)}{V_1} + \frac{x}{V_2}$$

Equation 5.3-7

We see from Equation 5.3-2 that

$$D_{TP} = \frac{h_P \cos(i_c)}{V_1}$$

Substituting into Equation 5.3-7 yields

$$T'_{AP} = D_{TP} + \frac{x}{V_2}$$

or the delay time at point P is

$$D_{TP} = T'_{AP} - \frac{x}{V_2}$$

Equation 5.3-8

Depth can then be calculated by solving Equation 5.3-2 for h_P :

$$h_P = \frac{D_{TP} V_1}{\cos(i_c)}$$

Equation 5.3-9

5.4 Appendix D - The Tomographic Method

The tomographic method, involves the creation of an initial velocity model, and then iteratively tracing rays through the model, comparing the calculated traveltimes to the measured traveltimes, modifying the model, and repeating the process until the difference between calculated and measured times is minimized. The math is quite complex; what is presented here assumes a working understanding of upper-level calculus and linear algebra.

The essential goal is to find the minimum traveltime between source and receiver for each source-receiver pair. This is accomplished by solving for l (raypath) and s (inverse velocity or “slowness”). Since we know neither, the problem is under-constrained, and we must use an iterative, least-squares approach.

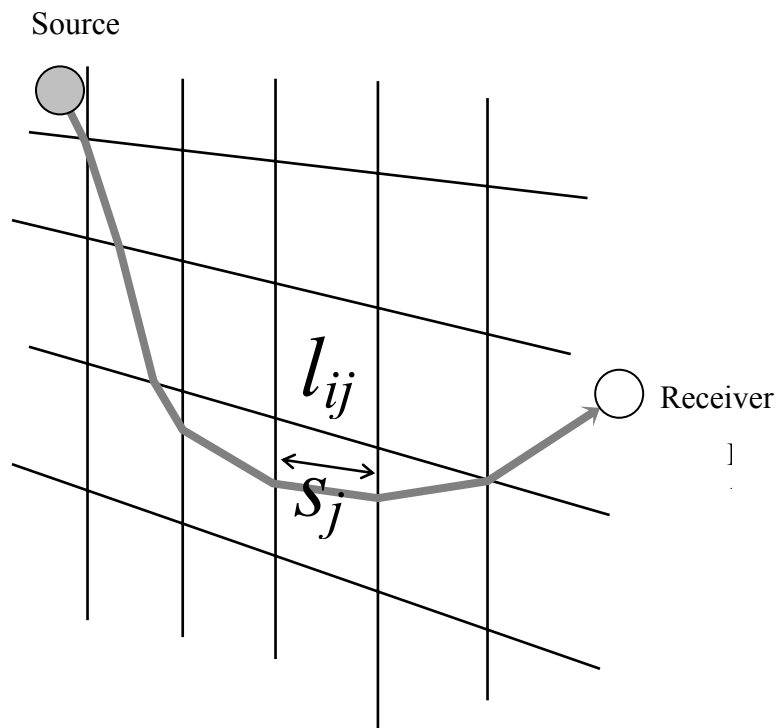

Definition:

$$s = \frac{1}{v}$$

s = “slowness”

v = velocity

l_{ij} = raypath

$$t_i = \int_X \frac{dX}{v(X)} = \int_X s(X) dX$$

In discrete form, we get,

$$t_i = s_1 l_{i1} + s_2 l_{i2} + s_3 l_{i3} + s_4 l_{i4} + \cdots + s_N l_{iN}$$

or

$$t_i = \sum_{j=1}^N s_j l_{ij}$$

We end up with M simultaneous equations (one for each travelttime), and N unknowns:

$$t_1 = l_{11}s_1 + l_{12}s_2 + \cdots + l_{1N}s_N$$

$$t_2 = l_{21}s_1 + l_{22}s_2 + \cdots + l_{2N}s_N$$

$$t_3 = l_{31}s_1 + l_{32}s_2 + \cdots + l_{3N}s_N$$

•

•

$$t_M = l_{M1}s_1 + l_{M2}s_2 + \cdots + l_{MN}s_N$$

In matrix notation, we get:

$$LS = \begin{pmatrix} l_{11} & l_{12} & \cdot & l_{1N} \\ l_{21} & l_{22} & \cdot & l_{2N} \\ l_{31} & l_{32} & \cdot & l_{3N} \\ \cdot & \cdot & \cdot & \cdot \\ l_{M1} & l_{M2} & \cdot & l_{MN} \end{pmatrix} \begin{pmatrix} s_1 \\ s_2 \\ \cdot \\ s_N \end{pmatrix} = \begin{pmatrix} t_1 \\ t_2 \\ \cdot \\ t_M \end{pmatrix} = T$$

Rapaths model traveltime

This is the Least Squares method. Generally, $M > N$.

Example 1: Three equations, two unknowns.

$$2x_1 + x_2 = 11$$

$$4x_1 + x_2 = 17$$

$$6x_1 + x_2 = 23$$

Unknowns are x_1 and x_2 .

In matrix notation, we get:

$$AX = \begin{pmatrix} 2 & 1 \\ 4 & 1 \\ 6 & 1 \end{pmatrix} \begin{pmatrix} x_1 \\ x_2 \end{pmatrix} = \begin{pmatrix} 11 \\ 17 \\ 23 \end{pmatrix} = Y$$

$$(AX=Y)$$

Matrix A is a Jacobian matrix:

$$f_1 = 2x_1 + x_2 - 11$$

$$f_2 = 4x_1 + x_2 - 17$$

$$f_3 = 6x_1 + x_2 - 23$$

or

$$A = \begin{pmatrix} 2 & 1 \\ 4 & 1 \\ 6 & 1 \end{pmatrix} = \begin{pmatrix} \frac{\partial f_1}{\partial x_1} & \frac{\partial f_1}{\partial x_2} \\ \frac{\partial f_2}{\partial x_1} & \frac{\partial f_2}{\partial x_2} \\ \frac{\partial f_3}{\partial x_1} & \frac{\partial f_3}{\partial x_2} \end{pmatrix}$$

$$\text{Error} = E = AX - Y$$

We want to minimize the sum of squares errors:

$$E = (AX - Y)^T (AX - Y) = \|AX - Y\|^2 \Rightarrow \text{Minimize}$$

We set the derivative of E to zero,

$$\frac{dE}{dX} = 2A^T(AX - Y) = 0$$

and solve for X :

$$(A^T A)X = A^T Y$$

Back to our three equations,

$$2x_1 + x_2 = 11$$

$$4x_1 + x_2 = 17$$

$$6x_1 + x_2 = 23$$

and solving,

$$(A^T A)X = \begin{pmatrix} 2 & 4 & 6 \\ 1 & 1 & 1 \end{pmatrix} \begin{pmatrix} 2 & 1 \\ 4 & 1 \\ 6 & 1 \end{pmatrix} \begin{pmatrix} x_1 \\ x_2 \end{pmatrix} = \begin{pmatrix} 2 & 4 & 6 \\ 1 & 1 & 1 \end{pmatrix} \begin{pmatrix} 11 \\ 17 \\ 23 \end{pmatrix} = A^T Y$$

$$(A^T A)X = \begin{pmatrix} 56 & 12 \\ 12 & 3 \end{pmatrix} \begin{pmatrix} x_1 \\ x_2 \end{pmatrix} = \begin{pmatrix} 228 \\ 51 \end{pmatrix} = A^T Y$$

$$X = (A^T A)^{-1} A^T Y = \begin{pmatrix} 0.125 & -0.5 \\ -0.5 & 2.3333 \end{pmatrix} \begin{pmatrix} 228 \\ 51 \end{pmatrix} = \begin{pmatrix} 3 \\ 5 \end{pmatrix}$$

So $x_1 = 3$ and $x_2 = 5$.

Example 2:

4 cells (velocity unknown).

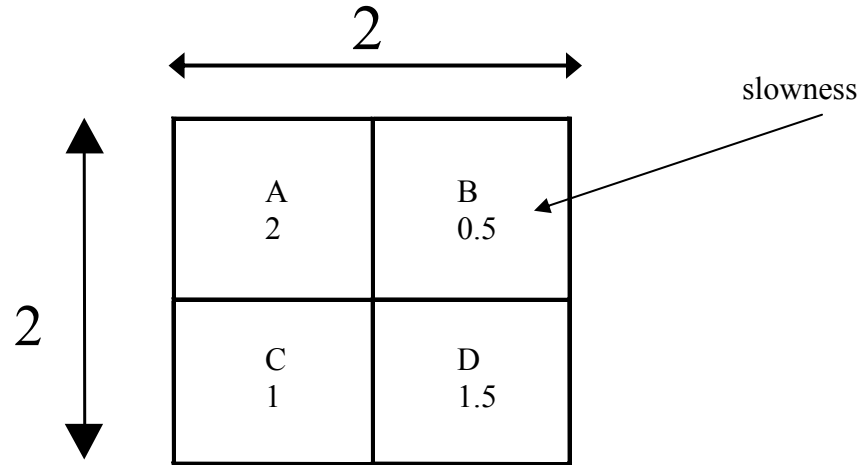

5 raypaths:

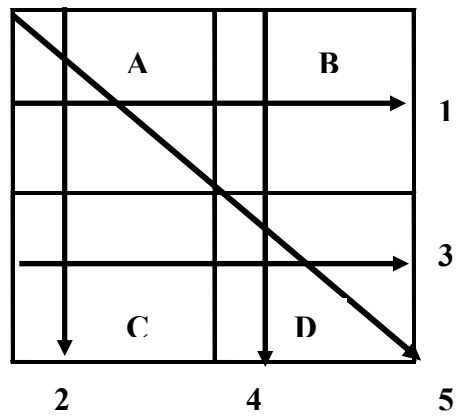

Observed traveltimes:

$$T = \begin{pmatrix} t_1 \\ t_2 \\ t_3 \\ t_4 \\ t_5 \end{pmatrix} = \begin{pmatrix} 2+0.5 \\ 2+1 \\ 1+1.5 \\ 0.5+1.5 \\ 2\sqrt{2}+1.5\sqrt{2} \end{pmatrix} = \begin{pmatrix} 2.5 \\ 3 \\ 2.5 \\ 2 \\ 4.949747 \end{pmatrix}$$

Jacobian matrix A (length of ray passing through each cell):

$$L = \begin{pmatrix} 1 & 1 & 0 & 0 \\ 1 & 0 & 1 & 0 \\ 0 & 0 & 1 & 1 \\ 0 & 1 & 0 & 1 \\ \sqrt{2} & 0 & 0 & \sqrt{2} \end{pmatrix}$$

$$t_i = s_1 l_{i1} + s_2 l_{i2} + s_3 l_{i3} + s_4 l_{i4} + \dots + s_N l_{iN}$$

$$\frac{\partial t_i}{\partial s_j} = l_{ij}$$

Equation to be solved:

$$LS = \begin{pmatrix} 1 & 1 & 0 & 0 \\ 1 & 0 & 1 & 0 \\ 0 & 0 & 1 & 1 \\ 0 & 1 & 0 & 1 \\ \sqrt{2} & 0 & 0 & \sqrt{2} \end{pmatrix} \begin{pmatrix} s_1 \\ s_2 \\ s_3 \\ s_4 \end{pmatrix} = \begin{pmatrix} 2.5 \\ 3 \\ 2.5 \\ 2 \\ 4.949747 \end{pmatrix} = T$$

Normal equation:

$$L^T L S = \begin{pmatrix} 4 & 1 & 1 & 2 \\ 1 & 2 & 0 & 1 \\ 1 & 0 & 2 & 1 \\ 2 & 1 & 1 & 4 \end{pmatrix} \begin{pmatrix} s_1 \\ s_2 \\ s_3 \\ s_4 \end{pmatrix} = \begin{pmatrix} 12.5 \\ 4.5 \\ 5.5 \\ 11.5 \end{pmatrix} = L^T T$$

$$S^T = (s_1 \quad s_2 \quad s_3 \quad s_4) = (2 \quad 0.5 \quad 1 \quad 1.5)$$

- Jacobian matrix requires ray-path
- Ray-path can not be calculated with out a velocity model
- Can not solve at once
- Must use *non-linear* Least Squares method

Non-linear Least Squares Method

If the Jacobian matrix is not a constant,

$$y(Z) = x_1 Z - x_2 e^{-Zx_3}$$

$$A = \begin{pmatrix} \frac{\partial y(z_1)}{\partial x_1} & \frac{\partial y(z_1)}{\partial x_2} & \frac{\partial y(z_1)}{\partial x_3} \\ \frac{\partial y(z_2)}{\partial x_1} & \frac{\partial y(z_2)}{\partial x_2} & \frac{\partial y(z_2)}{\partial x_3} \\ \vdots & \vdots & \vdots \\ \frac{\partial y(z_m)}{\partial x_1} & \frac{\partial y(z_m)}{\partial x_2} & \frac{\partial y(z_m)}{\partial x_3} \end{pmatrix} = \begin{pmatrix} z_1 & -e^{-Z_1 x_3} & -x_2 Z_1 e^{-Z_1 x_3} \\ z_2 & -e^{-Z_2 x_3} & -x_2 Z_2 e^{-Z_2 x_3} \\ \vdots & \vdots & \vdots \\ z_m & -e^{-Z_m x_3} & -x_2 Z_m e^{-Z_m x_3} \end{pmatrix}$$

parameter x is in the matrix A .

Iterative solution of a non-linear Least Squares matrix:

- 1) Calculate theoretical value Y_0 for initial value X_0 .

$$Y_0(Z) = Y(Z, X_0)$$

- 2) Calculate residuals (ΔY) between theoretical value Y_0 and observed value Y .

$$\Delta Y = Y - Y_0$$

- 3) Calculate correction value for X (ΔX) by the least squares method.

$$(A^T A)\Delta X = A^T \Delta Y$$

- 4) Calculate new estimate for X_1 .
- 5) Return to step 1.
- 6) Stop when residual error reaches acceptable value.

Example 3:

Model:

$$y(Z) = x_1 Z - x_2 e^{-Zx_3}$$

True solution:

$$X = \begin{pmatrix} x_1 \\ x_2 \\ x_3 \end{pmatrix} = \begin{pmatrix} 1 \\ 2 \\ 1 \end{pmatrix}$$

Eleven observed data:

z	y(z)
0	-2
1	0.26421
2	1.729329
3	2.900426
4	3.963369
5	4.986524
6	5.995042
7	6.998176
8	7.999329
9	8.999753
10	9.999909

Partial differentiation:

$$\frac{\partial y}{\partial x_1} = Z \qquad \frac{\partial y}{\partial x_2} = -e^{-Zx_3} \qquad \frac{\partial y}{\partial x_3} = x_2 Z e^{-Zx_3}$$

Initial model:

$$X_0 = \begin{pmatrix} x_1 \\ x_2 \\ x_3 \end{pmatrix} = \begin{pmatrix} 2 \\ 3 \\ 2 \end{pmatrix}$$

Jacobian matrix A:

$$A_0 = \begin{pmatrix} \frac{\partial y(z_1)}{\partial x_1} & \frac{\partial y(z_1)}{\partial x_2} & \frac{\partial y(z_1)}{\partial x_3} \\ \frac{\partial y(z_2)}{\partial x_1} & \frac{\partial y(z_2)}{\partial x_2} & \frac{\partial y(z_2)}{\partial x_3} \\ \vdots & \vdots & \vdots \\ \frac{\partial y(z_{11})}{\partial x_1} & \frac{\partial y(z_{11})}{\partial x_2} & \frac{\partial y(z_{11})}{\partial x_3} \end{pmatrix} = \begin{pmatrix} z_1 & -e^{-Z_1 x_3} & -x_2 Z_1 e^{-Z_1 x_3} \\ z_2 & -e^{-Z_2 x_3} & -x_2 Z_2 e^{-Z_2 x_3} \\ \vdots & \vdots & \vdots \\ z_{11} & -e^{-Z_{11} x_3} & -x_2 Z_{11} e^{-Z_{11} x_3} \end{pmatrix} = \begin{pmatrix} 0 & -1 & 0 \\ 1 & -0.1353352832 & 0.4060058497 \\ 2 & -0.0183156389 & 0.1098938333 \\ 3 & -0.0024787522 & 0.0223087696 \\ 4 & -0.0003354626 & 0.0040255515 \\ 5 & -0.0000453999 & 0.0006809989 \\ 6 & -0.0000061442 & 0.0001105958 \\ 7 & -0.0000008315 & 0.0000174621 \\ 8 & -0.0000001125 & 0.0000027008 \\ 9 & -0.0000000152 & 0.0000004112 \\ 10 & -0.0000000021 & 0.0000000618 \end{pmatrix}$$

Observed data:

$$Y^T = (-2.0000 \quad 0.264241 \quad 1.729329 \quad 2.900426 \quad 3.963369 \quad 4.986524 \quad 5.995042 \quad 6.998176 \quad 7.999329 \quad 8.999753 \quad 9.999909)$$

Theoretical data for the initial model:

$$\lambda_1^0 = (-3'0000 \quad 1'2240 \quad 3'2421 \quad 2'2252 \quad 1'2220 \quad 2'2222 \quad 15'0000 \quad 14'0000 \quad 12'0000 \quad 18'0000 \quad 20'0000)$$

Residual vector:

$$\Delta Y = Y_0 - Y$$

$$\nabla \lambda_1^0 = (-1'0000 \quad 1'3528 \quad 2'5121 \quad 3'0251 \quad 4'0322 \quad 2'0133 \quad 2'0042 \quad 1'0018 \quad 8'0001 \quad 2'0005 \quad 10'0001)$$

RMSE (Root Mean Square Error):

$$RMSE_0 = \sqrt{\frac{\Delta Y_0^T \Delta Y_0}{11}} = 5.9449$$

$$A_0^T A_0 = \begin{pmatrix} 385 & -0.181 & 0.71304 \\ -0.181 & 1.0187 & -0.057 \\ 0.71304 & -0.057 & 0.17743 \end{pmatrix} \quad A_0^T \Delta Y_0 = \begin{pmatrix} 386.3 \\ 0.7702 \\ 0.8728 \end{pmatrix}$$

Solve:

$$(A_0^T A_0) \Delta X_0 = A_0^T \Delta Y_0$$

Get:

$$\Delta X_0 = \begin{pmatrix} 1.0016 \\ 1.0021 \\ 1.2162 \end{pmatrix}$$

New estimated value for X (X_1):

$$X_1 = X_0 - \Delta X$$

$$X_1 = \begin{pmatrix} 2 \\ 3 \\ 2 \end{pmatrix} - \begin{pmatrix} 1.0016 \\ 1.0021 \\ 1.2162 \end{pmatrix} = \begin{pmatrix} 0.9984 \\ 1.9979 \\ 0.7838 \end{pmatrix}$$

Calculate residuals (RMSE) from new estimation of X (X_1):

$$RMSE_1 = \sqrt{\frac{\Delta Y_1^T \Delta Y_1}{11}} = 0.0793$$

In second calculation,

$$A_1^T A_1 = \begin{pmatrix} 385 & -1.543 & 8.19332 \\ -1.543 & 1.2635 & -0.6652 \\ 8.19332 & -0.6652 & 2.02955 \end{pmatrix} \quad A_1^T \Delta Y_1 = \begin{pmatrix} -1.854 \\ 0.123 \\ -0.372 \end{pmatrix}$$

Correction is:

$$\Delta X_1 = \begin{pmatrix} -0.001 \\ 0.002 \\ -0.179 \end{pmatrix}$$

Corrected model is:

$$X_2 = \begin{pmatrix} 0.9984 \\ 1.9979 \\ 0.7838 \end{pmatrix} - \begin{pmatrix} -0.001 \\ 0.002 \\ -0.179 \end{pmatrix} = \begin{pmatrix} 0.9994 \\ 1.9959 \\ 0.9625 \end{pmatrix} \cong \begin{pmatrix} 1 \\ 2 \\ 1 \end{pmatrix}$$

Residuals are:

$$RMSE_2 = \sqrt{\frac{\Delta Y_2^T \Delta Y_2}{11}} = 0.0122 \cong 0$$

Summary:

Simultaneous equations:

$$LS = T$$

L is a function of S (non-linear problem):

$$L(S)S = T$$

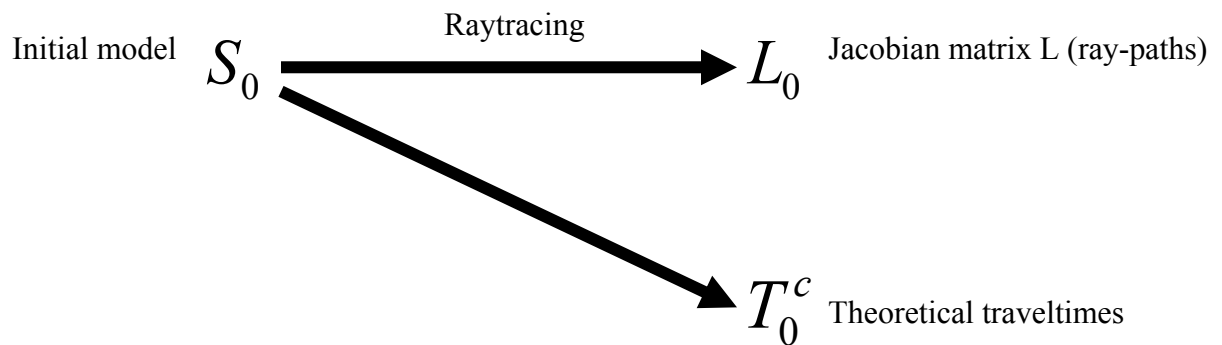

Then,

$$\Delta T_0 = T^O - T_0^C = T^O - L_0 S_0$$

Calculate correction:

$$L_0 \Delta S_0 = \Delta T_0$$

Correct model:

$$S_1 = S_0 + \Delta S_0$$

In the kth iteration:

$$\Delta T_k = T^O - T_k^C = T^O - L_k S_k$$

$$L_k \Delta S_k = \Delta T_k$$

$$S_{k+1} = S_k + \Delta S_k$$

Solve large matrix:

Use diagonal:

$$L^T L \Delta S = \begin{pmatrix} \sum_{i=1}^n l_{i1}^2 & 0 & \cdot & 0 \\ 0 & \sum_{i=1}^n l_{i2}^2 & \cdot & 0 \\ \cdot & \cdot & \cdot & \cdot \\ 0 & 0 & \cdot & \sum_{i=1}^n l_{im}^2 \end{pmatrix} \begin{pmatrix} \Delta S_1 \\ \Delta S_2 \\ \cdot \\ \Delta S_m \end{pmatrix} = \begin{pmatrix} \sum_{i=1}^n \Delta t_i l_{i1} \\ \sum_{i=1}^n \Delta t_i l_{i2} \\ \cdot \\ \sum_{i=1}^n \Delta t_i l_{im} \end{pmatrix} = L^T \Delta T$$

$$\Delta S_j = \frac{\sum_{i=1}^n \Delta t_i l_{ij}}{\sum_{i=1}^n l_{ij}^2} \cdot \alpha \cong \frac{\sum_{i=1}^n \left(\Delta t_i \frac{l_{ij}}{L_i} \right)}{\sum_{i=1}^n l_{ij}} = \frac{\sum_{i=1}^n \left(\Delta t_i \frac{t_{ij}}{T_i^c} \right)}{\sum_{i=1}^n l_{ij}} \quad L_i = \sum_{j=1}^m l_{ij}$$

$$T_i = \sum_{j=1}^m t_{ij}$$

Example 4:

From example 2:

$$LS = \begin{pmatrix} 1 & 1 & 0 & 0 \\ 1 & 0 & 1 & 0 \\ 0 & 0 & 1 & 1 \\ 0 & 1 & 0 & 1 \\ \sqrt{2} & 0 & 0 & \sqrt{2} \end{pmatrix} \begin{pmatrix} S_1 \\ S_2 \\ S_3 \\ S_4 \end{pmatrix} = \begin{pmatrix} 2.5 \\ 3 \\ 2.5 \\ 2 \\ 4.949747 \end{pmatrix} = T$$

Initial model:

$$S_0^T = (1 \ 1 \ 1 \ 1)$$

Calculate residuals:

$$\Delta T_0 = T - T_0^c = \begin{pmatrix} 2.5 \\ 3 \\ 2.5 \\ 2 \\ 4.9497 \end{pmatrix} - \begin{pmatrix} 2 \\ 2 \\ 2 \\ 2 \\ 2.8284 \end{pmatrix} = \begin{pmatrix} 0.5 \\ 1 \\ 0.5 \\ 0 \\ 2.1213 \end{pmatrix}$$

RMSE:

$$RMSE_0 = \sqrt{\frac{\Delta T^T \Delta T}{5}} = 2.44949$$

E.g., in the first cell,

$$\Delta s_j = \frac{\sum_{i=1}^n \left(\frac{\Delta t_i}{L_i} \right) l_{ij}}{\sum_{i=1}^n l_{ij}} = \frac{\frac{1}{2} \times 0.5 + \frac{1}{2} \times 1 + \frac{\sqrt{2}}{2\sqrt{2}} \times 2.1213}{1 + 1 + \sqrt{2}} = 0.53033$$

Similarly,

$$S_1 = S_0 + \Delta S = \begin{pmatrix} 1 \\ 1 \\ 1 \\ 1 \end{pmatrix} + \begin{pmatrix} 0.53033 \\ 0.125 \\ 0.375 \\ 0.383883 \end{pmatrix} = \begin{pmatrix} 1.53033 \\ 1.125 \\ 1.375 \\ 1.383883 \end{pmatrix} \quad (\text{Normal equation is not required})$$

Second iteration:

$$\Delta T_1 = T - T_1^c = \begin{pmatrix} 2.5 \\ 3 \\ 2.5 \\ 2 \\ 4.9497 \end{pmatrix} - \begin{pmatrix} 2.65533 \\ 2.90533 \\ 2.75888 \\ 2.50888 \\ 4.12132 \end{pmatrix} = \begin{pmatrix} -0.1553 \\ 0.09467 \\ -0.2589 \\ -0.5089 \\ 0.82843 \end{pmatrix}$$

RMSE:

$$RMSE_1 = \sqrt{\frac{\Delta T^T \Delta T}{5}} = 1.02243$$

General Summary:

Calculating traveltimes by raytracing,

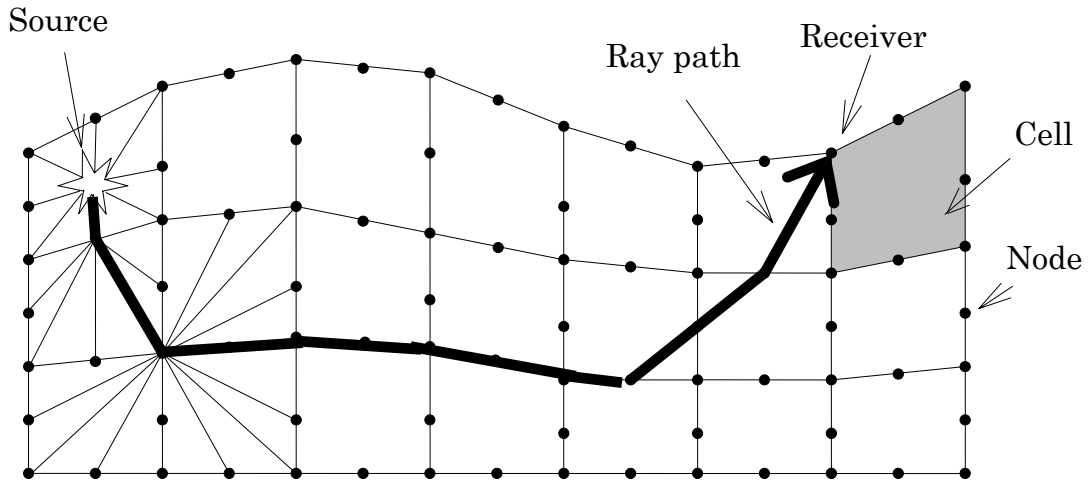

we want to calculate the shortest path between A and B:

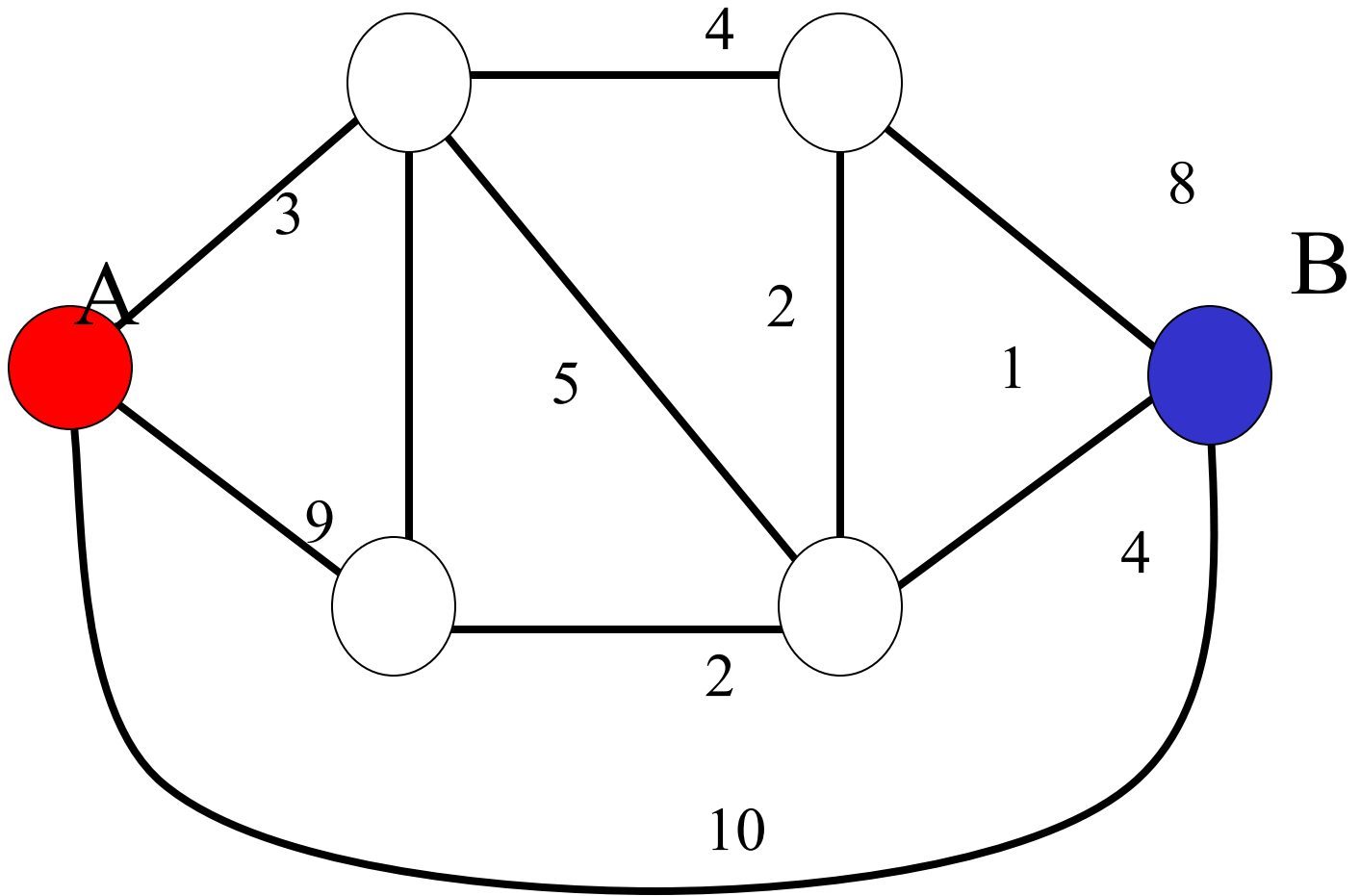

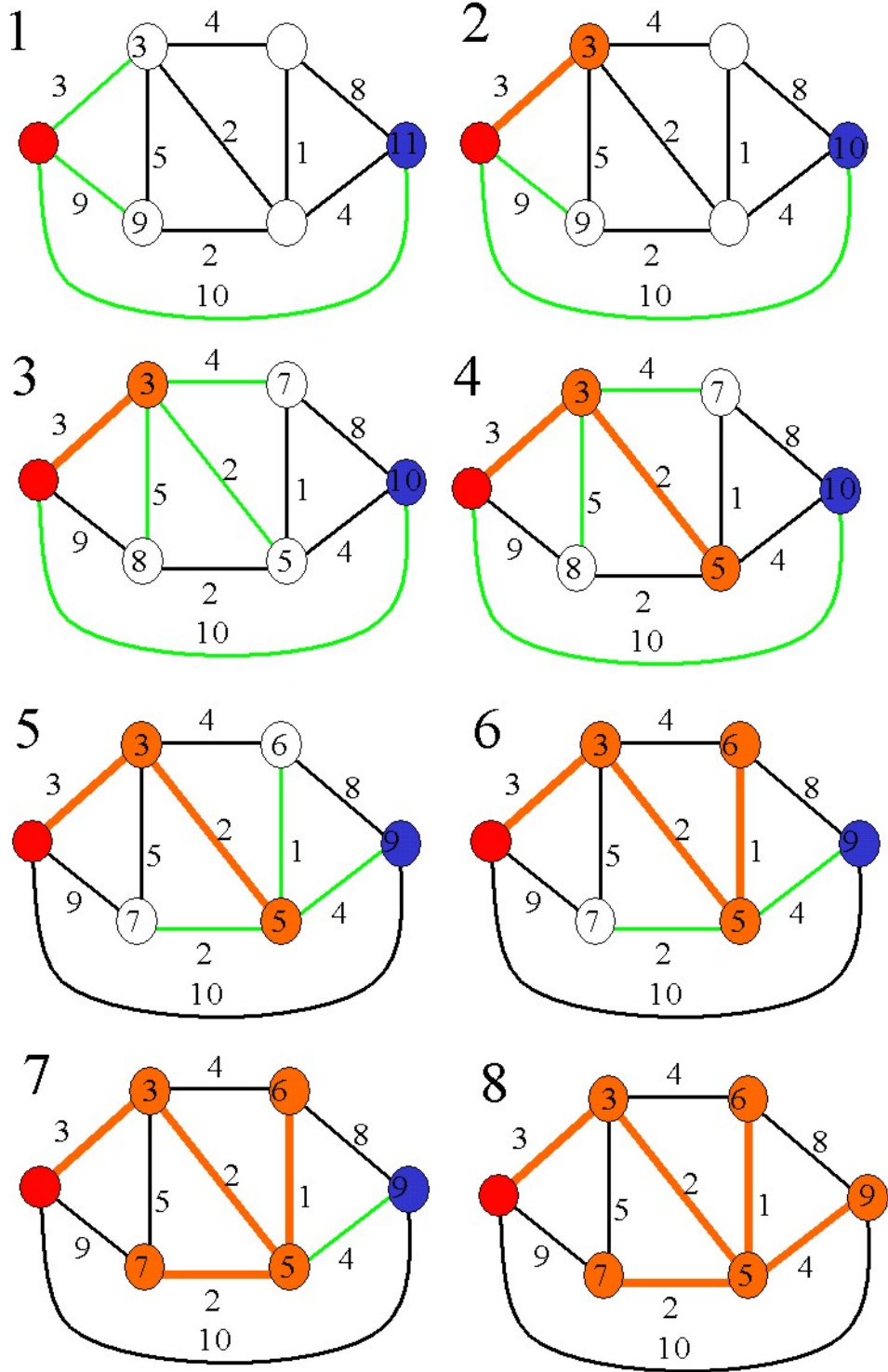

Some raytracing examples:

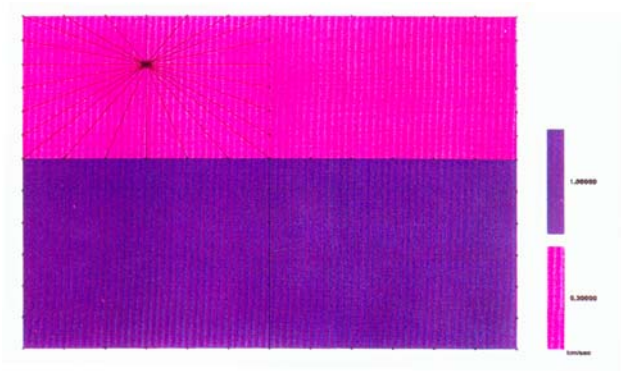

1

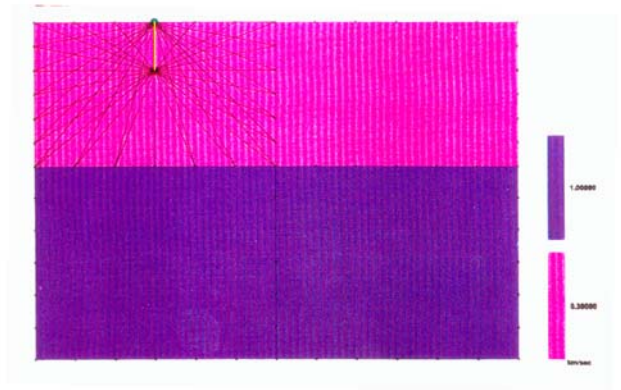

2

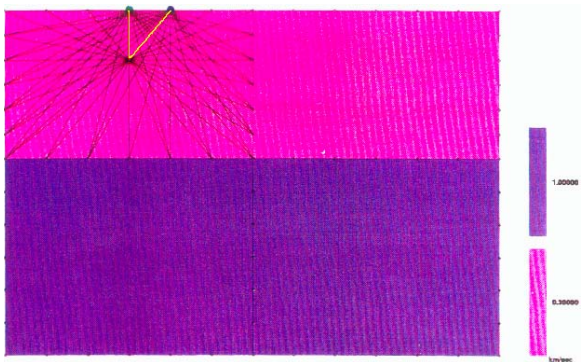

3

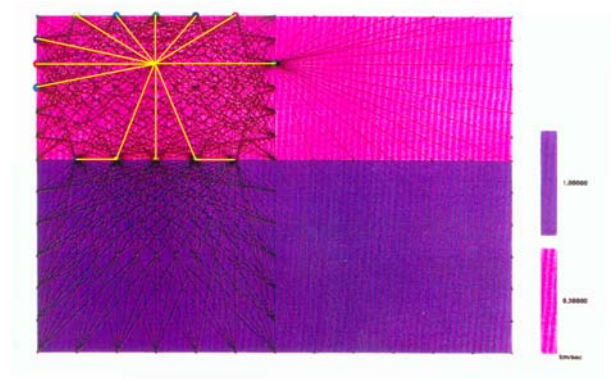

4

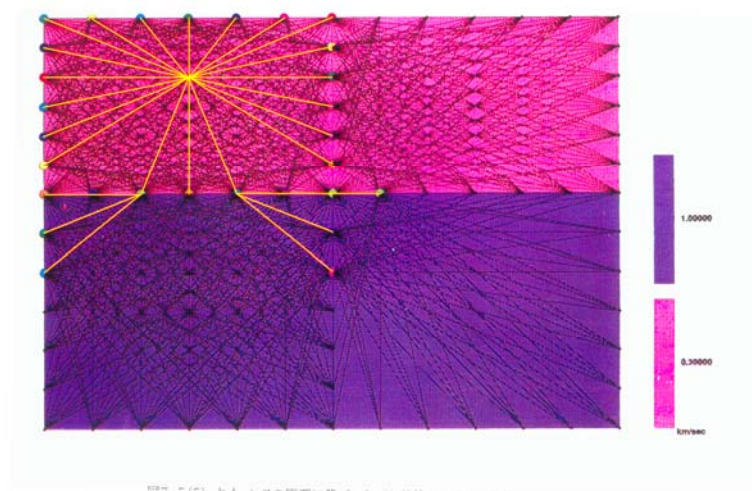

5

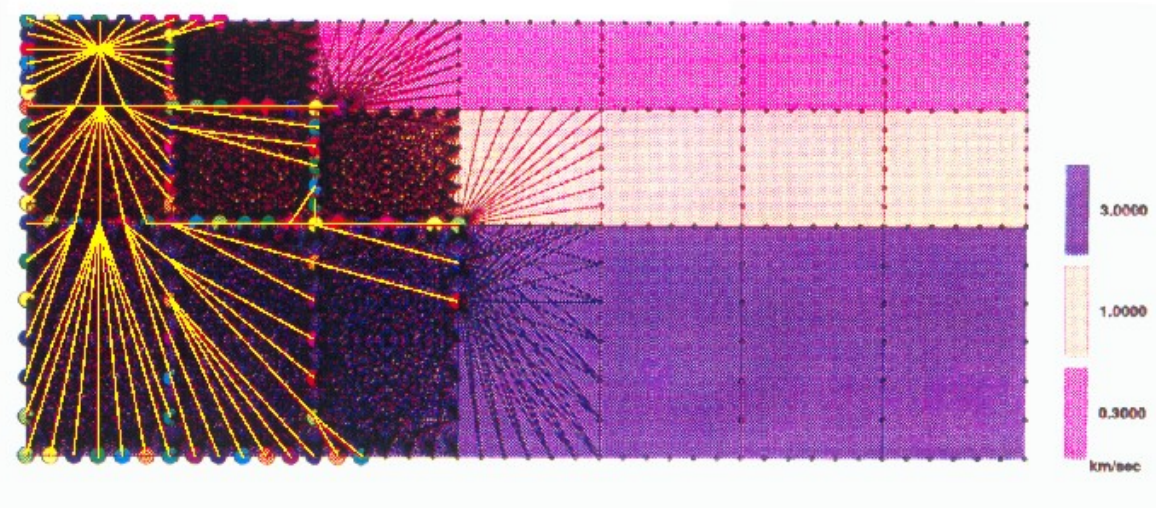
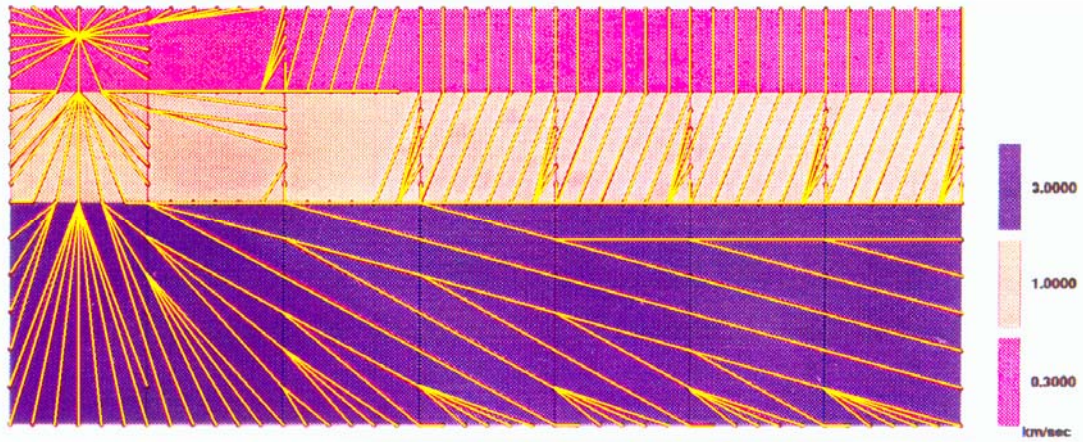

5.5 Appendix E - Recommended Reading

Crice, Doug, *Shear Wave Techniques and Systems*.

<ftp://geom.geometrics.com/pub/seismic/ShearWaves.pdf>

Caswell, Brad, *Seismic profiling aids well location*.*

<ftp://geom.geometrics.com/pub/seismic/Literature/s-tr162.pdf>

Dobecki, Tom L., *Seismic shear waves for lithology and saturation*.*

Dobrin, Milton B., *Introduction to Geophysical Prospecting*, 629 p. 1976.

Gorin, Stephen R., and Robert H. Gilkeson, *Use of the seismic refraction technique to optimize monitoring well locations at hazardous waste sites*.*

Haeni, F.P., *Application of seismic-refraction techniques to hydrologic studies*, USGS—TWRI Book 2, Chapter D2. 1988.

<ftp://geom.geometrics.com/pub/seismic/Literature/s-tr54.pdf>

Jackson, Don, *Rip instead of drilling and blasting*, reprinted from *Coal Age*.*

Langston, Robert W., *High resolution refraction data acquisition and interpretation*.*

Laymon, Douglas E., and Robert H. Gilkeson, *Application of seismic refraction methods to evaluate regional ground-water resources*.*

Palmer, Derecke, *The generalized reciprocal method of seismic refraction interpretation*, Society of Exploration Geophysicists, 104 p. 1980.

Redpath, Bruce B. *Seismic refraction exploration for engineering site investigations*, Explosive Excavation Research Laboratory, Livermore, California. 1973.

<ftp://geom.geometrics.com/pub/seismic/Literature/s-tr2.pdf>

Sirles, Phil C., and Andy Viksne, *Site-specific wave velocity determinations for geotechnical engineering applications*.*

* Available in hardcopy form from Geometrics. Visit our literature page for a complete list of available references.
<http://www.geometrics.com/LitForm/litform.html>

INDEX

- Add Random Noise to Traveltime Data, 147
- Adjust Velocity Line, 170
- Append PlotRefa File, 80
- Apply Custom Axis Configuration, 152
- Assign Layer 2 Arrivals, 157
- Assign Layer 3 Arrivals, 159
- Audio/video clip of Delay Time Determination, 177
- Audio/video clip of Difference-time Curve Calculation, 98
- Audio/video clip of Entire Delay Time Calculation Process, 179
- Audio/video clip of First Break Picking Procedure, 68
- Audio/video clip of Layer Assignments, 160
- Audio/video clip of Reverse-shot Delay Time Determination, 179
- Audio/video clip of Setting up T', 166
- Audio/video clip of Setting Velocity Line, 169
- Automatic Contour Interval, 126
- Automatic Shift, 47
- Axis Configuration, 65
- Axis Configuration (Automatic), 152
- Axis Configuration (Manual), 151
- Axis Title, 129
- Calculate Delay Times, 172
- Calculate Traveltime Difference Curve, 97
- Calculate Velocity Model From Delay Time Data, 181
- Check Reciprocal Traveltime, 98
- Clip Traces, 61
- Color <-> Monochrome, 125
- Color Shading, 120
- Color Traveltime Curves, 108
- Common Source <-> Common Receiver, 111
- Connect Common Source Traveltime Curves, 101
- Convert Into Layered Model, 192
- Convert Synthetic Data to "Observed" Data, 148
- Correct Reciprocal Time Automatically, 99
- Correct Shot Time, 45
- Correct S-wave, 51
- Correct Traveltime Curve For Shot Offset, 105
- Decimal Places of Velocity Label, 172
- Decrease Amplitude Tool Button, 71
- Decrease Horizontal Axis Tool Button, 73
- Decrease Vertical Axis Tool Button, 75
- Define Bottom Layer, 115
- Delay Time, 228
- Delete a Traveltime, 105
- Delete All T' Curves, 167
- Delete All Velocity Lines, 69, 172
- Delete Theoretical Traveltimes, 186
- Delete Trace, 43
- Dimension Size, 70, 197
- Do Time-term Inversion, 161
- Draw Traveltime Curve Tool Button, 76
- Edit Source/Receiver Locations, 58
- Edit Title, 198
- Enable Surface Topography Modification, 136
- Execute, 185
- Exit Edit Mode, 92, 135
- Exit Edit Mode Tool Button, 76
- Exit Program, 37, 91
- Extend Velocity Model to Remote Sources, 139
- File Menu, 23
- Filter, 54
- flow chart, 21, 156, 162, 187
- Fundamentals of Seismic Refraction, 202
- Generate Initial Model, 188
- Generate New Velocity Model, 146
- Highlight Velocity Labels, 119
- Import Elevation Data File, 84
- Increase Amplitude Tool Button, 71

Increase Vertical Axis Tool Button, 74
 Increase Horizontal Axis Tool Button, 72
 Inversion (Set Parameters Manually), 193
 Inversion (With Default Parameters), 190
 Kill Trace, 42
 Layer Assignment, 165
 Linear Velocity Line, 68
 Manual Contour Interval, 126
 Modify Delay Time (Times), 180
 Modify Delay Time (Velocities), 180
 Modify Layer Boundary (by Segment), 131
 Modify Layer Boundary (Point by Point), 131
 Modify Traveltimes (All Shots), 94
 Modify Traveltimes (Individual Shot Only), 96
 Modify Velocities (by Dialog Box), 135
 Modify Velocities (by Mouse), 133
 Normalize Traces, 60
 Number of Traces Shown, 64
 Open bpk Files, 83
 Open First Break Pick File, 25
 Open lpk Files, 84
 Open McSeis-3 File, 24
 Open PlotRefa File, 79
 Open SEG2 File, 23
 Open SEG2 File (SmartSeis), 24
 Page Setup, 28
 Page Setup, 90
 Pick First Breaks, 67
 Plot Velocity Labels, 117
 Pre-trigger Shift, 66
 Print, 89
 Print Preview, 27, 89
 Print Window Display, 27
 Raytracing, 185
 Reciprocal Time Method, 221
 Recommended Reading, 255
 Redo, 38
 Reduced Traveltimes, 225
 Resample Data, 57
 Reverse Legend, 129
 Reverse Polarity, 42
 Reverse Survey Line, 113
 Save Current Axis Configuration, 152
 Save First Break Pick File, 25
 Save PlotRefa File, 82
 Save Traveltime Curves (DXF Format), 86
 Save Velocity Model (DXF Format), 87
 Scale, 155
 Scroll Tool Buttons, 198
 Select All Traces, 39
 Select Trace, 38
 Set Location of Velocity Labels, 118
 Set up T^* ($1/2T_{(ab)}$ calculated automatically), 165
 Set up T^* ($1/2T_{(ab)}$ set manually), 167
 Set Velocity Line, 168
 Shift a Traveltime Curve, 96
 Show $1/2 T_{(ab)}$ Line, 167
 Show Cell Boundaries, 127
 Show Layer Assignments, 107
 Show Layer Boundaries, 127
 Show Observed Data, 110
 Show Raypath, 153
 Show RMS Error, 186
 Show Sources, 129
 Show Time-term, 153
 Show Traveltime Curves, 64
 Show Traveltime Curves, 153
 Show Velocity Model, 153
 Smooth, 137
 Source Lines, 109
 Straighten Layer Boundary, 133
 Time shift traces, 44
 Time-term Method, 217
 Tomographic Method, 232
 Tomography, 187
 Trace Shading, 62
 Truncate Traces, 56
 Undo, 37
 Units, 198
 Version Info, 70